



Department of Energy
Richland Operations Office
P.O. Box 550
Richland, Washington 99352

1226726
[0084874]

14-AMRP-0245

AUG 11 2014

Ms. J. A. Hedges, Program Manager
Nuclear Waste Program
State of Washington
Department of Ecology
3100 Port of Benton Blvd.
Richland, Washington 99354

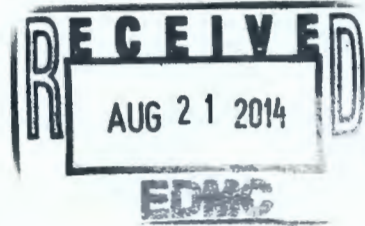

Dear Ms. Hedges:

TRANSMITTAL OF PROPOSED CLASS 2 RESOURCE CONSERVATION AND RECOVERY ACT PERMIT MODIFICATION AT THE HANFORD FACILITY LIQUID EFFLUENT RETENTION FACILITY AND 200 AREA EFFLUENT TREATMENT FACILITY (LERF/ETF) AND TEMPORARY AUTHORIZATION REQUEST

The U.S. Department of Energy Richland Operations Office (RL) as owner/operator and CH2M HILL Plateau Remediation Company (CHPRC) as the co-operator (hereinafter referred to as the Permittees) are proposing a Class 2 modification to unit specific addendum of the Liquid Effluent Retention Facility and 200 Area Effluent Treatment Facility (LERF/ETF) permit. The Permittees are requesting a Class 2 modification per WAC 173-303-830(4)(b) for LERF/ETF Addendum C, Process Information.

This modification request proposes to revise the approach to LERF liner repairs during operation. Recently, two small deficiencies were noted at the top of the basin liner in Basin 42, which is currently operating and receiving 242-A Evaporator waste. The liner vendor has been consulted and can repair the deficiency without requiring the draining of the basin. Therefore, the Permittees are requesting language changes in section C.5.2.4.1 of Addendum C, Process Information, to allow for repairs to occur without draining the basin. In addition, language is proposed to allow the vendor to select the most appropriate method to repair the liner. This change is classified as Class 2 permit modification request in WAC 173-303-830, Appendix I.A.4.b, "Changes in the frequency of or procedures for monitoring, reporting, sampling, or maintenance activities by the Permittees, Other Changes." A red-line strikeout of the proposed permit language is attached.

The Permittees are requesting a temporary authorization (TA) that meets the criteria of WAC 173-303-830(4) (e) (iii) (B) (III) to prevent disruption of ongoing waste management activities. A temporary authorization to implement the requested Class 2 modifications to the Permit will allow the repair to the LERF Basin 42 liner to occur and prevent disruption of receiving the 242-A Evaporator waste. A TA request that provides additional information and justification is attached to this permit modification request.

The notice required by the Permittees in WAC 173-303-830(4)(e)(ii)(C) will be included in the appropriate Hanford Federal Facility Agreement and Consent Order publication or list server, as described in Hanford Facility RCRA Permit Condition I.C.3.

AUG 11 2014

I certify under penalty of law that this document and all attachments were prepared under my direction or supervision in accordance with a system designed to assure that qualified personnel properly gather and evaluate the information submitted. Based on my inquiry of the person or persons who manage the system, or those persons directly responsible for gathering the information, the information submitted is, to the best of my knowledge and belief, true, accurate, and complete. I am aware that there are significant penalties for submitting false information, including the possibility of fine and imprisonment for knowing violations.

If you have any questions, please contact us, or your staff may contact Ray Corey, Assistant Manager for the River and Plateau, on (509) 373-9971.



Doug S. Shoop, Acting Manager
U.S. Department of Energy
Richland Operations Office

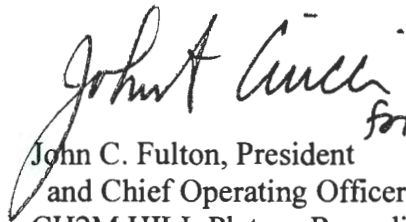

John C. Fulton, President
and Chief Operating Officer
CH2M HILL Plateau Remediation Company

AMRP:MSC

Attachments

cc w/attachs:

D. B. Bartus, EPA
G. Bohnee, NPT
F. W. Bond, Ecology
R. Buck, Wanapum
S. L. Dahl-Crumpler, Ecology
B. J. Dixon, CHPRC
D. A. Faulk, EPA
S. Harris, CTUIR
S. Hudson, HAB
R. Jim, YN
S. K. Johansen, CHPRC
E. T. McCarthy, CHPRC
K. Niles, ODOE
J. K. Perry, MSA
D. Rowland, YN
J. R. Seaver, CHPRC
E. R. Skinnarland, Ecology

Administrative Record, (LERF/ETF TSD: S-2-8)

Ecology NWP Library

Environmental Portal

LERF/ETF Temporary Authorization Request

The U.S. Department of Energy Richland Operations Office (RL) and CH2M HILL Plateau Remediation Company (CHPRC) are requesting that the State of Washington Department of Ecology (Ecology) grant a temporary authorization to approve the requested Class 2 modification to the Liquid Effluent Retention Facility and 200 Area Effluent Treatment Facility (LERF/ETF) Hanford Facility Resource Conservation and Recovery Act Permit, Dangerous Waste Portion (Permit),

These changes have been discussed with the Ecology, and receipt of waste from the 242-A Evaporator is a high priority for the RL and the U.S. Department of Energy Office of River Protection. Due to pressing need to correct the deficiency in the Basin 42 Liner to avoid disruption of waste receipt from the 242-A Evaporator, a temporary authorization is requested pursuant to the Washington Administrative Code (WAC) 173-303-830(4)(e) on this submitted permit modification.

This attachment reiterates the temporary authorization requirements outlined in the WAC **in bold** and provides the required information. To support planned waste receipts from the 242-A Evaporator at LERF/ETF, temporary authorization is requested by August 31, 2014.

WAC 173-303-830(4)(e) Temporary authorizations.

(i) Upon request of the permittee, the director may, without prior public notice and comment, grant the permittee a temporary authorization in accordance with this subsection. Temporary authorizations must have a term of not more than one hundred eighty days.

RL and CHPRC are requesting a temporary authorization for a full term of 180 days. The temporary authorization is needed to support repairs to the Basin 42 liner near the top of the basin and above the current liquid level in Basin 42. Repairs are needed prior to the 60 day public comment period due to concerns over the proper weather to perform the activities, as well as maintaining capacity to receive waste from site generators. In order to empty the basin, the contents would either need to be processed at ETF or transferred to another basin. Processing of effluent at ETF is not currently available due to upcoming repairs. Transferring the current Basin 42 contents to another Basin would also be problematic at this time. Basin 42 is stored and processed at pH range of 4-5 while Basin 43 and Basin 44 are stored and processed at a pH range of 10-11, due to their different chemical makeup of the waste water. Transferring the Basin 42 effluent to Basin 43 and Basin 44 will change the pH of all of the effluent and will result in treatment issues at ETF including release of ammonia gas and plugging of the drying vessels due to the chemistry change of the waste water. Finally, if the Basin 42 were required to be empty prior to the repair, waste receipts would be halted from the 242-A Evaporator, which would affect their operational abilities. Currently, the 242-A Evaporator processes tank retrieval waste and allow for additional room in double-shell tanks to become available.

LERF/ETF Temporary Authorization Request

(ii)(A) The permittee may request a temporary authorization for:

(1) Any Class 2 modification meeting the criteria in (e)(iii)(B) of this subsection

The Permittees (RL and CHPRC) are requesting a temporary authorization request that meets the criteria of WAC 173-303-830(e)(iii)(B)(IV) to prevent disruption of ongoing waste management activities. A temporary authorization to implement this change will allow a timely correction to the Basin 42 liner and will not require the Permittees to empty the entire basin to do the repair, which is near the top of the basin and above the current liquid level in the Basin 42.

(B) The temporary authorization request must include:

(I) A description of the activities to be conducted under the temporary authorization:

The modification request proposes to revise one addenda of the LERF/ETF Hanford Facility RCRA Permit, the Process Information (Addendum C) by updating the method of repairs to the liners are LERF/ETF Basin 42. This update will facilitate the liner vendor to do the repairs while the basin still contains waste, preventing an unnecessary emptying of the basin and disruption of waste receipts from the 242-A evaporator.

(C) The permittee must send a notice about the temporary authorization request to all persons on the facility mailing list maintained by the director and to appropriate units of state and local governments as specified in WAC 173-303-840 (3)(e)(i)(D). This notification must be made within seven days of submission of the authorization request.

Permit Condition I.C.3 allows for the Tri-Party Agreement processes to be used at the Hanford Facility for temporary authorization notifications. The notice for the Class 2 modification and the temporary authorization will be made within 7 days after transmitting the request to Ecology.

1	Addendum C	Process Information
2	C.	PROCESS INFORMATION C.1
3	C.1	LIQUID EFFLUENT RETENTION FACILITY PROCESS DESCRIPTION C.1
4	C.2	EFFLUENT TREATMENT FACILITY PROCESS DESCRIPTION C.2
5	C.2.1	Load-In Station C.3
6	C.2.2	Effluent Treatment Facility Operating Configuration C.3
7	C.2.3	Primary Treatment Train C.3
8	C.2.4	Secondary Treatment Train C.6
9	C.2.5	Other Effluent Treatment Facility Systems C.7
10	C.3	CONTAINERS C.9
11	C.3.1	Description of Containers C.10
12	C.3.2	Container Management Practices C.10
13	C.3.3	Container Labeling C.11
14	C.3.4	Containment Requirements for Managing Containers C.11
15	C.4	TANK SYSTEMS C.12
16	C.4.1	Design Requirements C.12
17	C.4.2	Additional Requirements for New Tanks C.17
18	C.4.3	Secondary Containment and Release Detection for Tank Systems C.17
19	C.4.4	Tank Management Practices C.22
20	C.4.5	Labels or Signs C.24
21	C.4.6	Air Emissions C.25
22	C.4.7	Management of Ignitable or Reactive Wastes in Tanks Systems C.25
23	C.4.8	Management of Incompatible Wastes in Tanks Systems C.25
24	C.5	SURFACE IMPOUNDMENTS C.25
25	C.5.1	List of Dangerous Waste C.25
26	C.5.2	Construction, Operation, and Maintenance of Liner System C.25
27	C.5.3	Prevention of Overtopping C.32
28	C.5.4	Structural Integrity of Dikes C.33
29	C.5.5	Piping Systems C.35 C.34
30	C.5.6	Double Liner and Leak Detection, Collection, and Removal System C.36
31	C.5.7	Construction Quality Assurance C.37
32	C.5.8	Proposed Action Leakage Rate and Response Action Plan C.37
33	C.5.9	Dike Structural Integrity Engineering Certification C.38 C.37
34	C.5.10	Management of Ignitable, Reactive, or Incompatible Wastes C.38 C.37
35	C.6	AIR EMISSIONS CONTROL C.38 C.37
36	C.6.1	Applicability of Subpart AA Standards C.38 C.37
37	C.6.2	Process Vents - Demonstrating Compliance C.38
38	C.6.3	Applicability of Subpart CC Standards C.39
39	C.7	ENGINEERING DRAWINGS C.40
40	C.7.1	Liquid Effluent Retention Facility C.40
41	C.7.2	200 Area Effluent Treatment Facility C.41
42		
43		

1 **Figures**

2	Figure C.1. Liquid Effluent Retention Facility Layout	C.48
3	Figure C.2. Plan View of the 200 Area Effluent Treatment Facility.....	C.49
4	Figure C.3. 200 Area Effluent Treatment Facility Layout	C.50
5	Figure C.4. 200 Area Effluent Treatment Facility	C.51
6	Figure C.5. Example - 200 Area Effluent Treatment Facility Configuration 1.....	C.52
7	Figure C.6. Example - 200 Area Effluent Treatment Facility Configuration 2.....	C.53
8	Figure C.7. Surge Tank	C.54
9	Figure C.8. Ultraviolet Light/Oxidation Unit.....	C.55
10	Figure C.9. Reverse Osmosis Unit	C.56
11	Figure C.10. Ion Exchange Unit.....	C.57
12	Figure C.11. Verification Tanks.....	C.58
13	Figure C.12. Effluent Treatment Facility Evaporator	C.59
14	Figure C.13. Thin Film Dryer	C.60
15	Figure C.14. Container Handling System	C.61
16	Figure C.15. Effluent Treatment Facility Sump Tanks	C.62
17	Figure C.16. Liner Anchor Wall and Cover Tension System	C.63
18	Figure C.17. Liner System Schematic.....	C.64
19	Figure C.18. Detail of Leachate Collection Sump	C.65

20 **Tables**

21	Table C.1. Liquid Effluent Retention Facility Containment System	C.41 C.40
22	Table C.2. Liquid Effluent Retention Facility Piping and Instrumentation	C.41
23	Table C.3. Effluent Treatment Facility and Load-In Station Secondary Containment Systems.....	C.41
24	Table C.4. Major Process Units and Tanks at the Effluent Treatment Facility and Load-In	
25	Station	C.42 C.41
26	Table C.5. 200 Area Effluent Treatment Facility Tank Systems Information	C.43
27	Table C.6. 200 Area Effluent Treatment Facility Additional Tank System Information.....	C.44
28	Table C.7. Ancillary Equipment and Material Data.....	C.45
29	Table C.8. Concrete and Masonary Coatings	C.46
30	Table C.9. Geomembrane Material Specifications.....	C.46
31	Table C.10. Drainage Gravel Specifications	C.47
32		

C. PROCESS INFORMATION

This addendum provides a detailed discussion of the LERF and 200 Area ETF processes and equipment. The LERF and 200 Area ETF comprise an aqueous waste treatment system located in the 200 East Area that provides storage and treatment for a variety of aqueous mixed waste. This aqueous waste includes process condensate from the 242-A Evaporator and other aqueous waste generated from onsite remediation and waste management activities.

The LERF consists of three lined surface impoundments, or basins. Aqueous waste from LERF is pumped to the 200 Area ETF for treatment in a series of process units, or systems, that remove or destroy essentially all of the dangerous waste constituents. The treated effluent is discharged to a State-Approved Land Disposal Site (SALDS) north of the 200 West Area, under the authority of a Washington State Waste Discharge Permit (Ecology 2000) and the Final Delisting ([40 CFR 261](#), Appendix IX, Table 2).

Both LERF and 200 Area ETF waste processing operations are controlled in a central Control room located in the 200 Area ETF building. The ETF control room is staffed continuously during ETF processing operations. Processing operations are defined as when liquid transfers of any sort are occurring to/from/within the LERF and ETF or when wastes are being treated at ETF¹. Examples of processing operations include, but are not limited to, when liquid waste are transferred to/from the LERF basins [see section C.1], during active liquid waste treatment/processing at the ETF (e.g., liquid waste treatment in tanks and liquid waste movement between primary and secondary treatment train processes and/or other ETF tanks [see Section C.2]), and liquid waste receipts at the load-in station [see Section C.2.1]). Section C.2.5.1 describes the centralized computer system (i.e., monitor and control system or MCS) that is located at the ETF control room and other locations at the ETF facility. This MCS monitors the performance of the ETF operations and records alarms from various equipment as described in this Addendum C and Addendum I, Inspection Requirements. At times when processing operations are not occurring, the ETF Control room is not manned continuously, and alarms are monitored daily as specified in Addendum I.

C.1 LIQUID EFFLUENT RETENTION FACILITY PROCESS DESCRIPTION

Each of the three LERF basins has an operating capacity of 29.5-million liters. The LERF receives aqueous waste through several inlets including the following:

- A pipeline that connects LERF with the 242-A Evaporator
- A pipeline from the 200 West Area
- A pipeline that connects LERF to the Load-In Station at the 200 Area ETF
- A series of sample ports located at each basin.

Figure C.1 presents a general layout of LERF and associated pipelines. Aqueous waste from LERF is pumped to the 200 Area ETF through one of two double-walled fiberglass transfer pipelines. Effluent from the 200 Area ETF also can be transferred back to the LERF through one of these transfer pipelines. These pipelines are equipped with leak detection located in the annulus between the inner and outer pipes. In the event that these leak detectors are not in service, the pipelines are visually inspected during transfers for leakage by opening the secondary containment drain lines located at the 200 Area ETF end of the transfer pipelines.

Each basin is equipped with six available sample risers constructed of 6-inch perforated pipe. A seventh sample riser in each basin is dedicated to influent aqueous waste receipt piping (except for aqueous waste received from the 242-A Evaporator), and an eighth riser in each basin contains liquid level instrumentation. Each riser extends along the sides of each basin from the top to the bottom of the basin and allows samples to be collected from any depth. Personnel access to these sample ports is from the perimeter area of the basins.

¹ *Liquid transfers does not include standard facility operations of liquid recirculation (e.g. for pump seals), sanitary water and cooling water, and outdoor rainwater management activities.*

1
2 A catch basin is provided at the northwest corner of each LERF basin for aboveground piping and
3 manifolds for transfer pumps. Aqueous waste from the 242-A Evaporator is transferred through piping
4 which ties into piping at the catch basins. Under routine operations, a submersible pump is used to
5 transfer aqueous waste from a LERF basin to the 200 Area ETF for processing or for basin-to-basin
6 transfers. This pump is connected to a fixed manifold on one of four available risers.

7 Each basin consists of a multilayer liner system supported by a concrete anchor wall around the basin
8 perimeter and a soil-bentonite clay underlayment. The multilayer liner system consists of a primary liner
9 in contact with the aqueous waste, a layer of bentonite carpet, a geonet, a geotextile, a gravel layer, and a
10 secondary liner that rests on the bentonite underlayment. Any aqueous waste leakage through the primary
11 liner flows through the geonet and gravel to a leachate collection system. The leachate flows to a sump at
12 the northwest corner of each basin, where the leachate is pumped up the side slope and back into the basin
13 above the primary liner. Each liner is constructed of high-density polyethylene. A floating cover made of
14 very low-density polyethylene is stretched over each basin above the primary liner. These covers serve to
15 keep unwanted material from entering the basins, and to minimize evaporation of the liquid contents.

16 **C.2 EFFLUENT TREATMENT FACILITY PROCESS DESCRIPTION**

17 The 200 Area ETF is designed as a flexible treatment system that provides treatment for contaminants
18 anticipated in process condensate and other onsite aqueous waste. The design influent flow rate into the
19 200 Area ETF is approximately 570 liters per minute, with planned outages for activities such as
20 maintenance on the 200 Area ETF systems. Maintenance outages typically are scheduled between
21 treating a batch of aqueous waste, referred to as treatment campaigns. The effluent flow (or volume) is
22 equivalent to the influent flow (or volume).

23 The 200 Area ETF generally receives aqueous waste directly from the LERF. However, aqueous waste
24 also can be transferred from tanker trucks at the Load-In Station to the 200 Area ETF and from containers
25 (e.g., carboys, drums) directly to ETF. Aqueous waste is treated and stored in the 200 Area ETF process
26 areas in a series of tank systems, referred to as process units. Within the ETF, waste also is managed in
27 containers through treatment and/or storage. Figure C.2 provides the relative locations of the process and
28 container storage areas within the ETF.

29 The process units are grouped in either the primary or the secondary treatment train. The primary
30 treatment train provides for the removal or destruction of contaminants. Typically, the secondary
31 treatment train processes the waste by-products from the primary treatment train by reducing the volume
32 of waste. In the secondary treatment train, contaminants are concentrated and dried to a powder. The
33 liquid fraction is routed to the primary treatment train. Figure C.3 provides an overview of the layout of
34 the ETF, 2025E Building). Figure C.4 presents the 200 Area ETF floor plan, the relative locations of the
35 individual process units and associated tanks within the ETF, and the location of the Load-In Station.

36 The dry powder waste and maintenance and operations waste are containerized and stored or treated in
37 the container storage areas or in collection or treatment areas within the Process Area. Secondary
38 containment is provided for all containers and tank systems (including ancillary equipment) housed
39 within the ETF. The trenches and floor of the 200 Area ETF comprise the secondary containment system.
40 The floor includes approximately a 15.2-centimeter rise (berm) along the containing walls of the process
41 and container storage areas. Any spilled or leaked material from within the process area or container
42 storage area is collected into trenches that feed into either sump tank 1 or sump tank 2. From these sump
43 tanks, the spilled or leaked material (i.e., waste) is fed to either the surge tank and processed in the
44 primary treatment train or the secondary waste receiving tanks and processed in the secondary treatment
45 train. All tank systems outside of the 200 Area ETF are provided with a secondary containment system.

46 In the following sections, several figures are provided that present general illustrations of the treatment
47 units and the relation to the process.

1 **C.2.1 Load-In Station**

2 The 200 Area ETF receives aqueous waste from LERF or the Load-In Station. The 200 Area ETF Load-
3 In Station, located due east of the surge tank and outside of the perimeter fence (Figure C.4), was
4 designed and constructed to provide the capability to unload, store, and transfer aqueous waste to the
5 LERF or 200 Area ETF from tanker trucks and other containers (such as drums). The Load-In Station
6 consists of two truck bays equipped with load-in tanks, transfer pumps, filtration system, level
7 instrumentation for tanker trucks, leak detection capabilities for the containment basin and transfer line,
8 and an underground transfer line that connects to lines in the surge tank berm, allowing transfers to either
9 the 200 Area ETF surge tank or LERF. The Load-In Station is covered with a steel building for weather
10 protection. Tanker trucks and other containers are used to unload aqueous waste at the Load-In Station.
11 To perform unloading, the tanker truck is positioned on a truck pad, a 'load-in' transfer line is connected
12 to the truck, and the tanker contents are pumped into one of the Load-In Station tanks, the surge tank, or
13 directly to the LERF. For container unloading, the container is placed on the truck pad and the container
14 contents are pumped into one of the Load-In Station tanks, the surge tank, or directly to the LERF.

15 During unloading operations, solids may be removed from the waste by pumping the contents of the
16 tanker truck or container through a filtration system. If solids removal is not needed, the filtration system
17 is not used and the solution is transferred directly to the Load-In Station tanks, surge tank, or to LERF.

18 Any leaks at the Load-In Station drain to the sump. A leak detector in the sump alarms locally and in the
19 200 Area ETF control room. Alarms are monitored continuously in the control room during Load-in
20 Station transfers and at least daily at times when waste is not being received at the Load-In Station.
21 Alternatively, leaks can be visually detected.

22 **C.2.2 Effluent Treatment Facility Operating Configuration**

23 Because the operating configuration of the 200 Area ETF can be adjusted or modified, most aqueous
24 waste streams can be effectively treated to below Delisting and Discharge Permit limits. The operating
25 configuration of the 200 Area ETF depends on the unique chemistry of an aqueous waste stream(s).
26 Before an aqueous waste stream is accepted for treatment, the waste is characterized and evaluated.
27 Information from the characterization is used to adjust the treatment process or change the configuration
28 of the 200 Area ETF process units, as necessary, to optimize the treatment process for a particular
29 aqueous waste stream.

30 Typically, an aqueous waste is processed first in the primary treatment train, where the 200 Area ETF is
31 configured to process an aqueous waste through the UV/OX unit first, followed by the RO unit.
32 However, under an alternate configuration, an aqueous waste could be processed in the RO unit first. For
33 example, high concentrations of nitrates in an aqueous waste might interfere with the performance of the
34 UV/OX. In this case, the 200 Area ETF could be configured to process the waste in the RO unit before
35 the UV/OX unit.

36 The flexibility of the 200 Area ETF also allows some aqueous waste to be processed in the secondary
37 treatment train first. For example, for small volume aqueous waste with high concentrations of some
38 anions and metals, the approach could be to first process the waste stream in the secondary treatment
39 train. This approach would prevent premature fouling or scaling of the RO unit. The liquid portion (i.e.,
40 untreated overheads from the 200 Area ETF evaporator and thin film dryer) would be sent to the primary
41 treatment train.

42 Figure C.5 and Figure C.6 provide example process flow diagrams for two different operating
43 configurations.

44 **C.2.3 Primary Treatment Train**

45 The primary treatment train consists of the following processes:

- 46 • Influent Receipt/Surge tank - inlet, surge capacity
- 47 • Filtration - for suspended solids removal

- 1 • UV/OX - organic destruction
- 2 • pH adjustment - waste neutralization
- 3 • Hydrogen peroxide decomposition - removal of excess hydrogen peroxide
- 4 • Degasification - removal of carbon dioxide
- 5 • RO - removal of dissolved solids
- 6 • IX - removal of dissolved solids
- 7 • Verification - holding tanks during verification

8 **Influent Receipt/Surge Tank.** Depending on the configuration of the ETF, the surge tank is one inlet
9 used to feed an aqueous waste into the 200 Area ETF for treatment. In Configuration 1 (Figure C.5), the
10 surge tank is the first component downstream of the LERF. The surge tank provides a storage/surge
11 volume for chemical pretreatment and controls feed flow rates from the LERF to the 200 Area ETF.
12 However, in Configuration 2 (Figure C.6), aqueous waste from LERF is fed directly into the treatment
13 units. In this configuration, the surge tank receives aqueous waste, which has been processed in the RO
14 units, and provides the feed stream to the remaining downstream process units. In yet another
15 configuration, some small volume aqueous waste could be received into the secondary treatment train
16 first for processing. In this case, the aqueous waste would be received directly into the secondary waste
17 receiving tanks. Finally, the surge tank also receives waste extracted from various systems within the
18 primary and secondary treatment train while in operation.

19 The surge tank is located outside the 200 Area ETF on the south side. In the surge tank (Figure C.7), the
20 pH of an aqueous waste is adjusted using the metered addition of sulfuric acid and sodium hydroxide, as
21 necessary, to prepare the waste for treatment in downstream processes. In addition, hydrogen peroxide or
22 biocides could be added to control biological growth in the surge tank. A pump recirculates the contents
23 in the surge tank, mixing the chemical reagents with the waste to a uniform pH.

24 **Filtration.** Two primary filter systems remove suspended particles in an aqueous waste: a rough filter
25 removes the larger particulates, while a fine filter removes the smaller particulates. The location of these
26 filters depends on the configuration of the primary treatment train. However, the filters normally are
27 located upstream of the RO units.

28 The solids accumulating on these filter elements are backwashed to the secondary waste receiving tanks
29 with pulses of compressed air and water, forcing water back through the filter. The backwash operation is
30 initiated either automatically by a rise in differential pressure across the filter or manually by an operator.
31 The filters are cleaned chemically when the backwashing process does not facilitate acceptable filter
32 performance.

33 Auxiliary fine and rough filters (e.g., disposable filters) have been installed to provide additional filtration
34 capabilities. Depending on the configuration of the ETF, the auxiliary filters are operated either in series
35 with the primary filters to provide additional filtration or in parallel, instead of the primary fine and rough
36 filters, to allow cleaning/maintenance of the primary fine and rough filters while the primary treatment
37 train is in operation.

38 **Ultraviolet Light/Oxidation.** Organic compounds contained in an aqueous waste stream are destroyed
39 in the UV/OX system (Figure C.8). Hydrogen peroxide is mixed with the waste. The UV/OX system
40 uses the photochemical reaction of UV light on hydrogen peroxide to form hydroxyl radicals and other
41 reactive species that oxidize the organic compounds. The final products of the complete reaction are
42 carbon dioxide, water, and inorganic ions.

43 Organic destruction is accomplished in two UV/OX units operating in parallel. During the UV/OX
44 process, the aqueous waste passes through reaction chambers where hydrogen peroxide is added. While
45 in the UV/OX system, the temperature of an aqueous waste is monitored. Heat exchangers are used to
46 reduce the temperature of the waste should the temperature of the waste approach the upper limits for the
47 UV/OX or RO systems.

1 **pH Adjustment.** The pH of a waste stream is monitored and controlled at different points throughout the
2 treatment process. Within the primary treatment train, the pH of a waste can be adjusted with sulfuric
3 acid or sodium hydroxide to optimize operation of downstream treatment processes or adjusted before
4 final discharge. For example, the pH of an aqueous waste would be adjusted in the pH adjustment tank
5 after the UV/OX process and before the RO process. In this example, pH is adjusted to cause certain
6 chemical species such as ammonia to form ammonium sulfate, thereby increasing the rejection rate of the
7 RO.

8 **Hydrogen Peroxide Decomposition.** Typically, hydrogen peroxide added into the UV/OX system is not
9 consumed completely by the system. Because hydrogen peroxide is a strong oxidizer, the residual
10 hydrogen peroxide from the UV/OX system is removed to protect the downstream equipment. The
11 hydrogen peroxide decomposer uses a catalyst to break down the hydrogen peroxide that is not consumed
12 completely in the process of organic destruction. The aqueous waste is sent through a column that breaks
13 down the hydrogen peroxide into water and oxygen. The gas generated by the decomposition of the
14 hydrogen peroxide is vented to the vessel off gas system.

15 **Degasification.** The degasification column is used to purge dissolved carbon dioxide from the aqueous
16 waste to reduce the carbonate loading to downstream dissolved solids removal processes within the
17 200 Area ETF primary treatment train. The purged carbon dioxide is vented to the vessel off gas system.

18 **Reverse Osmosis.** The RO system (Figure C.9) uses pressure to force clean water molecules through
19 semi-permeable membranes while keeping the larger molecule contaminants, such as dissolved solids,
20 and large molecular weight organic materials, in the membrane. The RO process uses a staged
21 configuration to maximize water recovery. The process produces two separate streams, including a clean
22 'permeate' and a concentrate (or retentate), which are concentrated as much as possible to minimize the
23 amount of secondary waste produced.

24 The RO process is divided into first and second stages. Aqueous waste is fed to the first RO stage from
25 the RO feed tank. The secondary waste receiving tanks of the secondary treatment train receive the
26 retentate removed from the first RO stage, while the second RO stage receives the permeate (i.e., 'treated'
27 aqueous waste from the first RO stage). In the second RO stage, the retentate is sent to the first stage RO
28 feed tank while the permeate is sent to the IX system or to the surge tank, depending on the configuration
29 of the ETF.

30 Two support systems facilitate this process. An anti-scale system injects scale inhibitors as needed into
31 the feed waste to prevent scale from forming on the membrane surface. A clean-in-place system using
32 cleaning agents, such as descalants and surfactants, cleans the membrane pores of surface and subsurface
33 deposits that have fouled the membranes.

34 **Ion Exchange.** Because the RO process removes most of the dissolved solids in an aqueous waste, the
35 IX process (Figure C.10) acts as a polishing unit. The IX system consists of three columns containing
36 beds of cation and/or anion resins. This system is designed to allow for regeneration of resins and
37 maintenance of one column while the other two are in operation. Though the two columns generally are
38 operated in series, the two columns also can be operated in parallel or individually.

39 Typically, the two columns in operation are arranged in a primary/secondary (lead/lag) configuration, and
40 the third (regenerated) column is maintained in standby. When dissolved solids breakthrough the first
41 IX column and are detected by a conductivity sensor, this column is removed from service for
42 regeneration, and the second column replaces the first column and the third column is placed into service.
43 The column normally is regenerated using sulfuric acid and sodium hydroxide. The resulting
44 regeneration waste is collected in the secondary waste receiving tanks.

45 Spent resins are transferred into a disposal container should regeneration of the IX resins become
46 inefficient. Free water is removed from the container and returned to the surge tank. Dewatered resins are
47 transferred to a final storage/disposal point.

1 **Verification.** The three verification tanks (Figure C.11) are used to hold the treated effluent while a
2 determination is made that the effluent meets discharge limits. The effluent can be returned to the
3 primary treatment train for additional treatment, or to the LERF, should a treated effluent not meet
4 Discharge Permit or Final Delisting requirements.

5 The three verification tanks alternate between three operating modes: receiving treated effluent, holding
6 treated effluent during laboratory analysis and verification, or discharging verified effluent. Treated
7 effluent may also be returned to the 200 Area ETF to provide 'clean' service water for operational and
8 maintenance functions, e.g., for boiler water and for backwashing the filters. This recycling keeps the
9 quantity of fresh water used to a minimum.

10 **C.2.4 Secondary Treatment Train**

11 The secondary treatment system typically receives and processes the following by-products generated
12 from the primary treatment train: concentrate from the first RO stage, filter backwash, regeneration waste
13 from the ion exchange system, and spillage or overflow received into the process sumps. Depending on
14 the operating configuration, however, some aqueous waste could be processed in the secondary treatment
15 train before the primary treatment train (refer to Figure C.5 and Figure C.6 for example operating
16 configurations).

17 The secondary treatment train provides the following processes:

- 18 • Secondary waste receiving - tank receiving and chemical addition
- 19 • Evaporation - concentrates secondary waste streams
- 20 • Concentrate staging - concentrate receipt, pH adjustment, and chemical addition
- 21 • Thin film drying - dewatering of secondary waste streams
- 22 • Container handling - packaging of dewatered secondary waste

23 **Secondary Waste Receiving.** Waste to be processed in the secondary treatment train is received into two
24 secondary waste receiving tanks, where the pH can be adjusted with sulfuric acid or sodium hydroxide for
25 optimum evaporator performance. Chemicals, such as reducing agents, may be added to waste in the
26 secondary waste receiving tanks to reduce the toxicity or mobility of constituents in the powder.

27 **Evaporation.** The 200 Area ETF evaporator is fed alternately by the two secondary waste receiving
28 tanks. One tank serves as a waste receiver while the other tank is operated as the feed tank. The
29 200 Area ETF evaporator vessel (also referred to as the vapor body) is the principal component of the
30 evaporation process (Figure C.12).

31 Feed from the secondary waste receiving tanks is pumped through a heater to the recirculation loop of the
32 200 Area ETF evaporator. In this loop, concentrated waste is recirculated from the 200 Area ETF
33 evaporator, to a heater, and back into the evaporator where vaporization occurs. As water leaves the
34 evaporator system in the vapor phase, the concentration of the waste in the evaporator increases. When
35 the concentration of the waste reaches the appropriate density, a portion of the concentrate is pumped to
36 one of the concentrate tanks.

37 The vapor that is released from the 200 Area ETF evaporator is routed to the entrainment separator, where
38 water droplets and/or particulates are separated from the vapor. The 'cleaned' vapor is routed to the vapor
39 compressor and converted to steam. The steam from the vapor compressor is sent to the heater (reboiler)
40 and used to heat the recirculating concentrate in the 200 Area ETF evaporator. From the heater, the steam
41 is condensed and fed to the distillate flash tank, where the saturated condensate received from the heater
42 drops to atmospheric pressure and cools to the normal boiling point through partial flashing (rapid
43 vaporization caused by a pressure reduction). The resulting distillate is routed to the surge tank. The
44 non-condensable vapors, such as air, are vented through a vent gas cooler to the vessel off gas system.

45 **Concentrate Staging.** The concentrate tanks make up the head end of the thin film drying process. From
46 the 200 Area ETF evaporator, concentrate is pumped into two concentrate tanks, and pH adjusted
47 chemicals, such as reducing agents, may be added to reduce the toxicity or mobility of constituents when
48 converted to powder. Waste is transferred from the concentrate tanks to the thin film dryer for conversion

1 to a powder. The concentrate tanks function alternately between concentrate receiver and feed tank for
2 the thin film dryer. However, one tank may serve as both concentrate receiver and feed tank.

3 Because low solubility solids (i.e., calcium and magnesium sulfate) tend to settle in the concentrate tanks,
4 these solids must be removed to prevent fouling and to protect the thin film dryer, and to maintain
5 concentrate tank capacity.

6 **Thin Film Drying.** From the concentrate tanks, feed is pumped to the thin film dryer (Figure C.13) that
7 is heated by steam. As the concentrated waste flows down the length of the dryer, the waste is dried. The
8 dried film, or powder, is scraped off the dryer cylinder by blades attached to a rotating shaft. The powder
9 is funneled through a cone-shaped powder hopper at the bottom of the dryer and into the Container
10 Handling System.

11 Overhead vapor released by the drying of the concentrate is condensed in the distillate condenser. Excess
12 heat is removed from the distillate by a water-cooled heat exchanger. Part of the distillate is circulated
13 back to the condenser spray nozzles. The remaining distillate is pumped to the surge tank. Any
14 noncondensable vapors and particulates from the spray condenser are exhausted to the vessel off gas
15 system.

16 **Container Handling.** Before an empty container is moved into the Container Handling System
17 (Figure C.14), the lid is removed and the container is placed on a conveyor. The containers are moved
18 into the container filling area after passing through an air lock. The empty container is located under the
19 thin film dryer, and raised into position. The container is sealed to the thin film dryer and a rotary valve
20 begins the transfer of powder to the empty container. Air displaced from the container is vented to the
21 distillate condenser attached to the 200 Area ETF evaporator that exhausts to the vessel off gas system.

22 The container is filled to a predetermined level, then lowered from the thin film dryer and moved along a
23 conveyor. The filled container is manually recapped, and moved along the conveyor to the airlock. At
24 the airlock, the container is moved onto the conveyor by remote control. The airlock is opened, the smear
25 sample (surface wipe) is taken, and the contamination level counted. A 'C' ring is installed to secure the
26 container lid. If the container has contaminated material on the outside, the container is wiped down and
27 retested. Filled containers that pass the smear test are labeled, placed on pallets, and moved by forklift to
28 the filled container storage area. Section C.3 provides a more detailed discussion of container handling.

29 **C.2.5 Other Effluent Treatment Facility Systems**

30 The 200 Area ETF is provided with support systems that facilitate treatment in the primary and secondary
31 treatment trains and that provide for worker safety and environmental protection. An overview of the
32 following systems is provided:

- 33 • Monitor and control system
- 34 • Vessel off gas system
- 35 • Sump collection system
- 36 • Chemical injection feed system
- 37 • Verification tank recycle system
- 38 • Utilities

39 **C.2.5.1 Monitor and Control System**

40 The operation of the 200 Area ETF is monitored and controlled by a centralized computer system (i.e.,
41 monitor and control system or MCS). The MCS continuously monitors data from various field indicators,
42 such as pH, flow, tank level, temperature, pressure, conductivity, alarm status, and valve switch positions.
43 Data gathered by the MCS enable operations and engineering personnel to document and adjust the
44 operation of the ETF.

45 Emergency communications equipment and warning systems (e.g. fire alarms and evacuation alarms) are
46 included in Addendum J, Contingency Plan. These emergency response notification alarms are

1 monitored continuously at central Hanford Facility locations (e.g. Hanford Fire Station) and do not rely
2 on staff being present in the ETF control room for notification and response.

3

4 **C.2.5.2 Vessel Off gas System**

5 Ventilation for various tanks and vessels is provided through the vessel off gas system. The system
6 includes a moisture separator, duct heater, pre-filter, high-efficiency particulate air filters, carbon absorber
7 (when required to reduce organic emissions), exhaust fans, and ductwork. Gasses ventilated from the
8 tanks and vessels enter the exhaust system through the connected ductwork. The vessel off gas system
9 draws vapors and gasses off the following tanks and treatment systems:

- 10 • Surge tank
- 11 • Vent gas cooler (off the ETF evaporator/distillate flash tank)
- 12 • pH adjustment tank
- 13 • Concentrate tanks
- 14 • Degasification system
- 15 • First and second RO stages
- 16 • Dry powder hopper
- 17 • Effluent pH adjustment tank
- 18 • Drum capping station
- 19 • Secondary waste receiving tanks
- 20 • Distillate condenser (off the thin film dryer)
- 21 • Sump tanks 1 and 2

22 The vessel off gas system maintains a negative pressure with respect to the atmosphere, which produces a
23 slight vacuum within tanks, vessels, and ancillary equipment for the containment of gas vapor. This
24 system also provides for the collection, monitoring, and treatment of confined airborne in-vessel
25 contaminants to preclude over-pressurization. The high-efficiency particulate air filters remove
26 particulates and condensate from the air stream before these are discharged to the heating, ventilation, and
27 air conditioning system.

28 **C.2.5.3 Sump Collection System**

29 Sump tanks 1 and 2 compose the sump collection system that provides containment of waste streams and
30 liquid overflow associated with the 200 Area ETF processes. The process area floor is sloped to two
31 separate trenches that each drain to a sump tank located under the floor of the 200 Area ETF
32 (Figure C.15). One trench runs the length of the primary treatment train and drains to Sump Tank 2,
33 located underneath the verification tank pump floor. The second trench collects spillage primarily from
34 the secondary treatment train and flows to Sump Tank 1, located near the 200 Area ETF evaporator.
35 Sump tanks 1 and 2 are located below floor level (Figure C.15). An eductor in these tanks prevents
36 sludge from accumulating.

37 **C.2.5.4 Chemical Injection Feed System**

38 At several points within the primary and secondary treatment trains, sulfuric acid and sodium hydroxide
39 (or dilute solutions of these reagents) are metered into specific process units to adjust the pH. For
40 example, a dilute solution of 4 percent sulfuric acid and 4 percent sodium hydroxide could be added to
41 the secondary waste receiving tanks to optimize the evaporation process.

42 **C.2.5.5 Verification Tank Recycle System**

43 To reduce the amount of water added to the process, verification tank water (i.e., verified effluent) is
44 recycled throughout the 200 Area ETF process. Tanks and ancillary equipment that use verification tank
45 water include:

- 46 • 4 percent H₂SO₄ solution tank and ancillary equipment
- 47 • 4 percent NaOH solution tank and ancillary equipment

- 1 • Clean-in-place tank and ancillary equipment
- 2 • IX columns (during resin regeneration)
- 3 • 200 Area ETF evaporator boiler and ancillary equipment
- 4 • Thin film dryer boiler and ancillary equipment
- 5 • Seal water system. In addition, verification tank water is used extensively during maintenance
- 6 activities. For example, it may be used to flush piping systems or to confirm the integrity of piping, a
- 7 process tank or tank truck.

8 **C.2.5.6 Utilities**

9 The 200 Area ETF maintains the following utility supply systems required for the operation of the ETF:

- 10 • Cooling water system - removes heat from process water via heat exchangers and a cooling tower
- 11 • Compressed air system - provides air to process equipment and instrumentation
- 12 • Seal water system - provides cool, clean, pressurized water to process equipment for pump seal
- 13 cooling and pump seal lubrication, and provides protection against failure and fluid leakage
- 14 • Demineralized water system - removes solids from raw water system to produce high quality, low
- 15 ion-content, water for steam boilers, and for the hydrogen peroxide feed system.
- 16 • Heating, ventilation, and air conditioning system - provides continuous heating, cooling, and air
- 17 humidity control throughout the ETF.

18 The following utilities support 200 Area ETF activities:

- 19 • Electrical power
- 20 • Sanitary water
- 21 • Communication systems
- 22 • Raw water

23 **C.3 CONTAINERS**

24 This section provides specific information on container storage and treatment operations at the 200 Area
25 ETF, including descriptions of containers, labeling, and secondary containment structures.

26 A list of dangerous and/or mixed waste managed in containers at the 200 Area ETF is presented in
27 Addendum A. The types of dangerous and/or mixed waste managed in containers in the 200 Area ETF
28 could include:

- 29 • Secondary waste powder generated from the treatment process
- 30 • Aqueous waste received from other Hanford site sources awaiting treatment
- 31 • Miscellaneous waste generated by operations and maintenance activities.

32 The secondary treatment train processes the waste by-products from the primary treatment train, which
33 are concentrated and dried into a powder. Containers are filled with dry powder waste from the thin film
34 dryer via a remotely controlled system. Containers of aqueous waste received from other Hanford site
35 sources are stored at 200 Area ETF until their contents can be transferred to the process for treatment.
36 The waste is usually transferred to the secondary waste receiving or concentration tanks. Miscellaneous
37 waste generated from maintenance and operations activities are stored at the ETF. The waste could
38 include process waste, such as used filter elements; spent RO membranes; damaged equipment, and
39 decontamination and maintenance waste, such as contaminated rags, gloves, and other personal protective
40 equipment. Containers of miscellaneous waste which have free liquids generally are packaged with
41 absorbents.

42 Several container collection areas could be located within the 200 Area ETF process and container
43 handling areas. These collection areas are used only to accumulate waste in containers. Once a container
44 is filled, the container is transferred to a container storage area (Figure C.3 and Figure C.4), to another
45 TSD unit, or to a less-than-90-day storage pad. Containers stored in the additional storage area
46 (Figure C.4) are elevated or otherwise protected from contact with accumulated liquids. The container
47 storage area within 200 Area ETF is a 22.9 x 8.5-meter room located adjacent to the 200 Area ETF

1 process areas. The containers within the container storage area are clearly labeled, and access to these
2 containers is limited by barriers and by administrative controls. The 200 Area ETF floor provides
3 secondary containment, and the 200 Area ETF roof and walls protects all containers from exposure to the
4 elements.

5 Waste also could be placed in containers for treatment as indicated in Addendum A. For example, sludge
6 that accumulates in the bottoms of the process tanks is removed periodically and placed into containers.
7 In this example, the waste is solidified by decanting the supernate from the container and the remainder of
8 the waste is allowed to evaporate, or absorbents are added, as necessary, to address remaining liquids.
9 Following treatment, this waste either is stored at the 200 Area ETF or transferred to another TSD unit.

10 **C.3.1 Description of Containers**

11 The containers used to collect and store dry powder waste are 208-liter steel containers. Most of the
12 aqueous waste received at 200 Area ETF, and maintenance and operation waste generated, are stored in
13 208-liter steel or plastic containers; however, in a few cases, the size of the container could vary to
14 accommodate the size of a particular waste. For example, some process waste, such as spent filters,
15 might not fit into a 208-liter container. In the case of spent resin from the IX columns, the resin is
16 dewatered, and could be packaged in a special disposal container. In these few cases, specially sized
17 containers could be required. In all cases, however, only approved containers are used and are compatible
18 with the associated waste. Typically, 208-liter containers are used for treatment.

19 Current operating practices indicate the use of new 208-liter containers that have either a polyethylene
20 liner or a protective coating. Any reused or reconditioned container is inspected for container integrity
21 before use. Overpack containers are available for use with damaged containers. Overpack containers
22 typically are unlined steel or polyethylene.

23 Per Addendum A, a maximum of 147,630 liters of dangerous and/or mixed waste could be stored in
24 containers in the 200 Area ETF.

25 **C.3.2 Container Management Practices**

26 Before use, each container is checked for signs of damage such as dents, distortion, corrosion, or
27 scratched coating. For dry powder loading, empty containers on pallets are raised by a forklift and
28 manually placed on the conveyor that transports the containers to the automatic filling station in the
29 container handling room (Figure C.14). The container lids are removed and replaced manually following
30 the filling sequence. After filling, containers exit the container handling room via the filled drum
31 conveyor. Locking rings are installed, the container label is affixed, and the container is moved by dolly
32 or forklift to the container storage area.

33 Before receipt at 200 Area ETF, each container from other Hanford site sources is inspected for leaks,
34 signs of damage, and a loose lid. The identification number on each container is checked to ensure the
35 proper container is received. The containers are typically placed on pallets and moved by dolly or forklift
36 to the container storage area. These containers are later moved to the process area and the contents
37 transferred to the process for treatment.

38 Containers used for storing maintenance and operations secondary waste are labeled before being placed
39 in the container storage area or in a collection area. Lids are secured on these containers when not being
40 filled. When the containers in a collection area are full, the containers are transferred by dolly or forklift
41 to the container storage area or to an appropriate TSD unit. Containers used for treating waste also are
42 labeled. The lids on these containers are removed as required to allow for treatment. During treatment,
43 access to these containers is controlled through physical barriers and/or administrative controls.

44 The filled containers in the container storage area are inventoried, checked for proper labeling, and placed
45 on pallets or in a separate containment device as necessary. Each pallet is moved by forklift. Within the
46 container storage area, palletized containers are stacked no more than three pallets high and in rows no
47 more than two containers wide. Unobstructed aisles with a minimum of 76-centimeter aisle space
48 separate rows.

1 **C.3.3 Container Labeling**

2 Labels are affixed on containers used to store dry powder when the containers leave the container
3 handling room. Labels are affixed on other waste containers before use. Every container is labeled with
4 the date that the container was filled. Appropriate major risk labels, such as "corrosive", "toxic", or
5 "F-listed", also are added. Each container also has a label with an identification number for tracking
6 purposes.

7 **C.3.4 Containment Requirements for Managing Containers**

8 Secondary containment is provided in the container management areas within the ETF. The secondary
9 containment provided for tank systems also serves the container management areas. This section
10 describes the design and operation of the secondary containment structure for these areas.

11 **C.3.4.1 Secondary Containment System Design**

12 For the container management areas, the reinforced concrete floor and a 15.2-centimeter rise (berm) along
13 the walls of the container storage area of the 200 Area ETF provides secondary containment. The
14 engineering assessment required for tanks (Mausshardt 1995) also describes the design and construction
15 of the secondary containment provided for the 200 Area ETF container management areas. All systems
16 were designed to national codes and standards (e.g., American Society for Testing Materials, American
17 Concrete Institute standards).

18 The floor is composed of cast-in-place, pre-formed concrete slabs, and has a minimum thickness of 15.2
19 centimeters. All slab joints and floor and wall joints have water stops installed at the mid-depth of the
20 slab. In addition, filler was applied to each joint. The floor and berms are coated with a chemically
21 resistant; high-solids epoxy coating system consisting of primer and top coating. This coating material is
22 compatible with the waste managed in containers and is an integral part of the secondary containment
23 system for containers.

24 The floor is sloped to drain any solution in the container storage area to floor drains along the west wall.
25 Each floor drain consists of a grating over a 20.3-centimeter diameter drain port connected to a 4-inch
26 polyvinyl chloride transfer pipe. The pipe passes under this wall and connects to a trench running along
27 the east wall of the adjacent process area. This trench drains solution to sump tank 1.

28 The container storage area is separated from the process area by a common wall and a door for access to
29 the two areas (Figure C.3). These two areas also share a common floor and trenches that, with the
30 15.2-centimeter rise of the containing walls, form the secondary containment system for the process area
31 and the container storage area.

32 **C.3.4.2 Structural Integrity of Base**

33 Engineering calculations were performed showing the floor of the container storage area is capable of
34 supporting the weight of containers. These calculations were reviewed and certified by a professional
35 engineer (Mausshardt 1995). The concrete was inspected for damage during construction. Cracks were
36 identified and repaired to the satisfaction of the professional engineer. Documentation of these
37 certifications is included in the engineering assessment (Mausshardt 1995).

38 **C.3.4.3 Containment System Capacity**

39 The container storage area is primarily used to store dry powder, aqueous waste awaiting treatment, and
40 maintenance and operation waste. Where appropriate, absorbents are added to fix any trace liquids
41 present. Large volumes of liquid are not stored in the container storage area. However, liquids might be
42 present in those containers that are in the treatment process. The maximum volume of waste that can be
43 stored in containers in the container storage area is 147,630 liters.

44 Because they are interconnected by floor drains, both the process area and the container storage area are
45 considered in the containment system capacity. The volume available for secondary containment in the
46 process area is approximately 68,000 liters, as discussed in the engineering assessment (Mausshardt

1995). Using the dimensions of the container storage area (23.6 by 8.5 by 0.2 meters), and assuming that 50 percent of the floor area is occupied by containers, the volume of the container storage area is 15,300 liters. The Truck Bay loading areas (see Figure C.4) also provides 10,500 liters of containment as it is connected to the other two areas. The combined volume of the Truck Bay loading areas and process area, and container handling area available for secondary containment, is 93,800 liters. This volume is greater than 10 percent of the maximum total volume of containers allowed for storage in the ETF, as discussed previously.

C.3.4.4 Control of Run-on

The container management areas are located within the ETF, which serves to prevent run-on of precipitation.

C.3.4.5 Removal of Liquids from Containment Systems

The container storage area is equipped with drains that route solution to a trench in the process area, which drains to sump tank 1. The sump tanks are equipped with alarms that notify operating personnel that a leak is occurring. The sump tanks also are equipped with pumps to transfer waste to the surge tank or the secondary treatment train.

C.3.4.6 Prevention of Ignitable, Reactive, and Incompatible Wastes in Containers

Individual waste types (i.e., ignitable, corrosive, and reactive) are stored in separate containers. A waste that could be incompatible with other wastes is separated and protected from the incompatible waste. Incompatible wastes are evaluated using the methodology documented in [40 CFR 264](#), Appendix V. For example, acidic and caustic wastes are stored in separate containers. Free liquids are absorbed in miscellaneous waste containers that hold incompatible waste. Additionally, ETF-specific packaging requirements for these types of waste provide extra containment with each individual container. For example, each item of acidic waste is individually bagged and sealed within a lined container.

C.4 TANK SYSTEMS

This section provides specific information on tank systems and process units. This section also includes a discussion on the types of waste to be managed in the tanks, tank design information, integrity assessments, and additional information on the 200 Area ETF tanks that treat and store dangerous and/or mixed waste. The 200 Area ETF dangerous waste tanks are identified in Section 4C.4.1.1, and the relative locations of the tanks and process units in the 200 Area ETF are presented in Figure C.3.

C.4.1 Design Requirements

The following sections provide an overview of the design specifications for the tanks within the ETF. A separate discussion on the design of the process units also is provided. In accordance with the new tank system requirements of [WAC 173-303-640\(3\)](#), the following tank components and specifications were assessed:

- Dimensions, capacities, wall thicknesses, and pipe connections
- Materials of construction and linings and compatibility of materials with the waste being processed
- Materials of construction of foundations and structural supports
- Review of design codes and standards used in construction
- Review of structural design calculations, including seismic design basis
- Waste characteristics and the effects of waste on corrosion

This assessment was documented in the *Final RCRA Information Needs Report* (Mausshardt 1995; the engineering assessment performed for the 200 Area ETF tank systems by an independent professional engineer. A similar assessment of design requirements was performed for Load-in tanks 59A-TK-109 and -117 and is documented in *200 Area Effluent BAT/AKART Implementation, ETF Truck Load-in Facility, Project W-291H Integrity Assessment Report* (KEH 1994). An assessment was also performed when Load-in tank 59A-TK-1 was placed into service for receipt of dangerous and mixed wastes. The

1 assessment is documented in *200 Area ETF Purgewater Unloading Facility Tank System Integrity*
2 *Assessment* (HNF 2009a).

3 The specifications for the preparation, design, and construction of the tank systems at the 200 Area ETF
4 are documented in the *Design Construction Specification, Project C-018H, 242-A Evaporator/PUREX*
5 *Plant Process Condensate Treatment Facility* (WHC 1992a). The preparation, design, and construction
6 of Load-in tanks 59A-TK-109 and -117 are provided in the construction specifications in *Project W-291,*
7 *200 Area Effluent BAT/AKART Implementation ETF Truck Load-in Facility* (KEH 1994). The
8 preparation, design and construction of Load-in 59A-TK-1 are documented in *Purgewater Unloading*
9 *Facility Project Documentation* (HNF 2009b).

10 Most of the tanks in the 200 Area ETF are constructed of stainless steel. According to the design of the
11 ETF, it was determined stainless steel would provide adequate corrosion protection for these tanks.
12 Exceptions include Load-in tank 59A-TK-1, which is constructed of fiberglass-reinforced plastic and the
13 verification tanks, which are constructed of carbon steel with an epoxy coating. The 200 Area ETF
14 evaporator/vapor body (and the internal surfaces of the thin film dryer) is constructed of a corrosion
15 resistant alloy, known as alloy 625, to address the specific corrosion concerns in the secondary treatment
16 train. Finally, the hydrogen peroxide decomposer vessels are constructed of carbon steel and coated with
17 a vinyl ester lining.

18 The shell thicknesses of the tanks identified in Table C.5 represent a nominal thickness of a new tank
19 when placed into operation. The tank capacities identified in this table represent the maximum volumes.
20 Nominal tank volumes discussed below represent the maximum volume in a tank unit during normal
21 operations.

22 **C.4.1.1 Codes and Standards for Tank System Construction**

23 Specific standards for the manufacture of tanks and process systems installed in the 200 Area ETF are
24 briefly discussed in the following sections. In addition to these codes and industrial standards, a seismic
25 analysis for each tank and process system is required [[WAC 173-303-806\(4\)\(a\)\(xi\)](#)]. The seismic
26 analysis was performed in accordance with UCRL-15910 *Design and Evaluation Guidelines for*
27 *Department of Energy Facilities Subjected to Natural Phenomena Hazards*, Section 4 (UCRL 1987).
28 The results of the seismic analyses are summarized in the engineering assessment of the 200 Area ETF
29 tank systems (Mausshardt 1995).

30 **Storage and Treatment Tanks.** The following tanks store and/or treat dangerous waste at the ETF.

31 <u>Tank name</u>	<u>Tank number</u>
32 Surge tank	2025E-60A-TK-1
33 pH adjustment tank	2025E-60C-TK-1
34 Effluent pH adjustment tank	2025E-60C-TK-2
35 First RO feed tank	2025E-60F-TK-1
36 Second RO feed tank	2025E-60F-TK-2
37 Verification tanks (three)	2025E-60H-TK-1A/1B/1C
38 Secondary waste receiving tanks (two)	2025E-60I-TK-1A/1B
39 Evaporator (vapor body)	2025E-601-EV-1
40 Concentrate tanks (two)	2025E-60J-TK-1A/1B
41 Sump tanks (two)	2025E-20B-TK-1/2
42 Distillate flash tank	2025E-60I-TK-2
43 Load-in tanks	2025ED-59A-TK-1/109/117

44 The relative location of these tanks is presented in Figure C.3. These tanks are maintained at or near
45 atmospheric pressure. The codes and standards applicable to the design, construction, and testing of the
46 above tanks and ancillary piping systems are as follows:

47 ASME - B31.3 Chemical Plant and Petroleum Refinery Piping (ASME 1990)

48 ASME Sect. VIII, Division I Pressure Vessels (ASME 1992a)

- 1 AWS - D1.1 Structural Welding Code - Steel (AWS 1992)
- 2 ANSI - B16.5 Pipe Flanges and Flanged Fittings (ANSI 1992)
- 3 ASME Sect. IX Welding and Brazing Qualifications (ASME 1992b)
- 4 API 620 Design and Construction of Large Welded Low Pressure Storage Tanks (API 1990)
- 5 AWWA - D100 Welded Steel Tanks for Water Storage (AWWA 1989)
- 6 AWWA - D103 Factory-Coated Bolted Steel Tanks for Water Storage (AWWA 1987)
- 7 AWWA - D120 Thermosetting Fiberglass-Reinforced Plastic Tanks (AWWA 1984)
- 8 ASTM-D3299 Filament Wound Glass-Fiber-Reinforced Thermoset Resin Corrosion Resistant Tanks.

9
10 The application of these standards to the construction of 200 Area ETF tanks and independent verification
11 of completed systems ensured that the tank and tank supports had sufficient structural strength and that
12 seams and connections were adequate to ensure tank integrity. In addition, each tank met strict quality
13 assurance requirements. Each tank constructed offsite was tested for integrity and leak tightness before
14 shipment to the Hanford Facility. Following installation, the systems were inspected for damage to
15 ensure against leakage and to verify proper operation. If a tank was damaged during shipment or
16 installation, leak tightness testing was repeated onsite.

17 **C.4.1.2 Design Information for Tanks Located Outside of Effluent Treatment Facility**

18 The load-in tanks, surge tank, and verification tanks are located outside the ETF. These tanks are located
19 within concrete structures that provide secondary containment.

20 **Load-In Tanks and Ancillary Equipment.** The load-in tanks 59A-TK-109 and -117 are heated and
21 constructed of stainless steel, and have a nominal capacity of 31,000 liters. Load-in tank 59A-TK-1 is
22 heated and constructed of fiberglass reinforced plastic and has a nominal capacity of 24,500 liters. Load-
23 in tanks 59A-TK-109 and -117 are located outside of the metal building while Load-in tank 59A-TK-1 is
24 located inside the building. Ancillary equipment includes transfer pumps, filtration systems, a double
25 encased, fiberglass transfer pipeline, level instruments for tanker trucks, and leak detection equipment.
26 From the Load-In Station, aqueous waste can be routed to the surge tank or to the LERF through a
27 double-encased line. The load-in tanks, sump, pumps, and truck pad are all provided with secondary
28 containment.

29 **Surge Tank and Ancillary Equipment.** The surge tank is constructed of stainless steel and has a
30 nominal capacity of 421,000 liters. Ancillary equipment to the surge tank includes two underground
31 double encased (i.e., pipe-within-a-pipe) transfer lines connecting to LERF and three pumps for
32 transferring aqueous waste to the primary treatment train. The surge tank is located at the south end of
33 the ETF. The surge tank is insulated and the contents heated to prevent freezing. Eductors in the tank
34 provide mixing.

35 **Verification Tanks and Ancillary Equipment.** The verification tanks are located north of the ETF.
36 The verification tanks have a nominal capacity of 2,760,000 liters each. For support, the tanks have a
37 center post with a webbing of beams that extend from the center post to the sides of the tank. The roof is
38 constructed of epoxy covered carbon steel that is attached to the cross beams of the webbing. The tank
39 floor also is constructed of epoxy covered carbon steel and is sloped. Eductors are installed in each tank
40 to provide mixing.

41 Ancillary equipment includes a return pump that provides circulation of treated effluent through the
42 eductors. The return pump also recycles effluent back to the 200 Area ETF for retreatment and can
43 provide service water for 200 Area ETF functions. Two transfer pumps are used to discharge treated
44 effluent to SALDS or back to the LERF.

1 **C.4.1.3 Design Information for Tanks Located Inside the Effluent Treatment Facility**
2 **Building**

3 Most of the 200 Area ETF tanks and ancillary equipment that store or treat dangerous and/or mixed waste
4 are located within the ETF. The structure serves as secondary containment for the tank systems.

5 **pH Adjustment Tank and Ancillary Equipment.** The pH adjustment tank has a nominal capacity of
6 16,000 liters. Ancillary equipment for this tank includes overflow lines to a sump tank and pumps to
7 transfer waste to other units in the main treatment train.

8 **Effluent pH Adjustment Tank and Ancillary Equipment.** The effluent pH adjustment tank has a
9 nominal capacity of 13,700 liters. Ancillary equipment includes overflow lines to a sump tank and pumps
10 to transfer waste to the verification tanks.

11 **First and Second Reverse Osmosis Feed Tanks and Ancillary Equipment.** The first RO feed tank is a
12 vertical, stainless steel tank with a round bottom and has a nominal capacity of 19,700 liters. Conversely,
13 the second RO feed tank is a rectangular vessel with the bottom of the tank sloping sharply to a single
14 outlet in the bottom center. The second RO feed tank has a nominal capacity of 7,800 liters. Each RO
15 tank has a pump to transfer waste to the RO arrays. Overflow lines are routed to a sump tank.

16 **Secondary Waste Receiving Tanks and Ancillary Equipment.** Two nominal 69,000-liter secondary
17 waste receiving tanks collect waste from the units in the main treatment train, such as concentrate solution
18 (retentate) from the RO units and regeneration solution from the IX columns. These are vertical,
19 cylindrical tanks with a semi-elliptical bottom and a flat top. Ancillary equipment includes overflow lines
20 to a sump tank and pumps to transfer aqueous waste to the 200 Area ETF evaporator.

21 **Effluent Treatment Facility Evaporator and Ancillary Equipment.** The 200 Area ETF evaporator,
22 the principal component of the evaporation process, is a cylindrical pressure vessel with a conical bottom.
23 Aqueous waste is fed into the lower portion of the vessel. The top of the vessel is domed and the vapor
24 outlet is configured to prevent carryover of liquid during the foaming or bumping (violent boiling) at the
25 liquid surface. The 200 Area ETF evaporator has a nominal operating capacity of approximately
26 18,500 liters.

27 The 200 Area ETF evaporator includes the following ancillary equipment:

- 28 • Preheater
- 29 • Recirculation pump
- 30 • Waste heater with steam level control tank
- 31 • Concentrate transfer pump
- 32 • Entrainment separator
- 33 • Vapor compressor with silencers
- 34 • Silencer drain pump.

35 **Distillate Flash Tank and Ancillary Equipment.** The distillate flash tank is a horizontal tank that has a
36 nominal operating capacity of 780 liters. Ancillary equipment includes a pump to transfer the distillate to
37 the surge tank for reprocessing.

38 **Concentrate Tanks and Ancillary Equipment.** Each of the two concentrate tanks has an approximate
39 nominal capacity of 22,700 liters. Ancillary equipment includes overflow lines to a sump tank and pumps
40 for recirculation and transfer.

41 **Sump Tanks.** Sump tanks 1 and 2 are located below floor level. Both sump tanks are double-walled,
42 rectangular tanks, placed inside concrete vaults. Both tanks have a working volume of 4,000 liters each.
43 The sump tanks are located in pits below grade to allow gravity drain of solutions to the tanks. Each
44 sump tank has two vertical pumps for transfer of waste to the secondary waste receiving tanks or to the
45 surge tank for reprocessing.

1 **C.4.1.4 Design Information for Effluent Treatment Facility Process Units**

2 As with the 200 Area ETF tanks, process units that treat and/or store dangerous and/or mixed waste are
3 maintained at or near atmospheric pressure. These units were constructed to meet a series of design
4 standards, as discussed in the following sections. Table C.6 presents the materials of construction and the
5 ancillary equipment associated with these process units. All piping systems are designed to withstand the
6 effects of internal pressure, weight, thermal expansion and contraction, and any pulsating flow. The
7 design and integrity of these units are presented in the engineering assessment (Mausshardt 1995).

8 **Filters.** The load-in fine and rough filter vessels (including the influent and auxiliary filters) are designed
9 to comply with the ASME Section VIII, Division I, Pressure Vessels (ASME 1992a). The application of
10 these standards to the construction of the 200 Area ETF filter system and independent inspection ensure
11 that the filter and filter supports have sufficient structural strength and that the seams and connections are
12 adequate to ensure the integrity of the filter vessels.

13 **Ultraviolet Oxidation System.** The UV/OX reaction chamber is designed to comply with manufacturers
14 standards.

15 **Degasification System.** The codes and standards applicable to the design, fabrication, and testing of the
16 degasification column are identified as follows:

- 17 • ASME - B31.3, Chemical Plant and Petroleum Refinery Piping (ASME 1990)
- 18 • AWS - D1.1, Structural Welding Code - Steel (AWS 1992)
- 19 • ANSI - B16.5, Pipe Flanges and Flanged Fittings (ANSI 1992)

20 **Reverse Osmosis System.** The pressure vessels in the RO unit are designed to comply with ASME
21 Section VIII, Division I, Pressure Vessels (ASME 1992a), and applicable codes and standards.

22 **Ion Exchange (Polishers).** The IX columns are designed in accordance with ASME Section VIII,
23 Division I, Pressure Vessels (ASME 1992a), and applicable codes and standards. Polisher piping is
24 fabricated of type 304 stainless steel or polyvinyl chloride (PVC) and meets the requirements of
25 ASME B31.3, Chemical Plant and Petroleum Refinery Piping (ASME 1990).

26 **Effluent Treatment Facility Evaporator.** The 200 Area ETF evaporator is designed to meet the
27 requirements of ASME Section VIII, Division I, Pressure Vessels (ASME 1992a), and applicable codes
28 and standards. The 200 Area ETF evaporator piping meets the requirements of ASME B31.3, Chemical
29 Plant and Petroleum Refinery Piping (ASME 1990).

30 **Thin Film Dryer System.** The thin film dryer is designed to meet the requirements of ASME
31 Section VIII, Division I, Pressure Vessels (ASME 1992a), and applicable codes and standards. The
32 piping meets the requirements of ASME - B31.3, Chemical Plant and Petroleum Refinery Piping
33 (ASME 1990).

34 **C.4.1.5 Integrity Assessments.**

35 The integrity assessment for 200 Area ETF (Mausshardt 1995) attests to the adequacy of design and
36 integrity of the tanks and ancillary equipment to ensure that the tanks and ancillary equipment will not
37 collapse, rupture, or fail over the intended life considering intended uses. For the load-in tanks, a similar
38 integrity assessment was performed (KEH 1995 and HNF 2009a). Specifically, the assessment
39 documents the following considerations:

- 40 • Adequacy of the standards used during design and construction of the facility
- 41 • Characteristics of the solution in each tank
- 42 • Adequacy of the materials of construction to provide corrosion protection from the solution in each
43 tank
- 44 • Results of the leak tests and visual inspections

1 The results of these assessments demonstrate that tanks and ancillary equipment have sufficient structural
2 integrity and are acceptable for storing and treating dangerous and/or mixed waste. The assessments also
3 state that the tanks and building were designed and constructed to withstand a design-basis earthquake.
4 Independent, qualified registered professional engineers certified these tank assessments.

5 The scope of the 200 Area ETF tank integrity assessment was based on characterization data from process
6 condensate. To assess the effect that other aqueous waste might have on the integrity of the 200 Area
7 ETF tanks, the chemistry of an aqueous waste will be evaluated for its potential to corrode a tank (e.g.,
8 chloride concentrations will be evaluated). The tank integrity assessment for the load-in tanks was based
9 on characterization data from several aqueous waste streams. The chemistry of an aqueous waste stream
10 not considered in the load-in tank integrity assessment also will be evaluated for the potential to corrode a
11 load-in tank.

12 Consistent with the recommendations of the integrity assessment, a corrosion inspection program was
13 developed. Periodic integrity assessments are scheduled for those tanks predicted to have the highest
14 potential for corrosion. These inspections are scheduled annually or longer, based on age of the tank
15 system, materials of construction, characteristics of the waste, operating experience, and
16 recommendations of the initial integrity assessment. These 'indicator tanks' include the concentrate
17 tanks, secondary waste receiving tanks, and verification tanks. One of each of these tanks will be
18 inspected yearly to determine if corrosion or coating failure has occurred. Should significant corrosion or
19 coating failure be found, an additional tank of the same type would be inspected during the same year. In
20 the case of the verification tanks, if corrosion or coating failure is found in the second tank, the third tank
21 also will be inspected. If significant corrosion were observed in all three sets of tanks, the balance of the
22 200 Area ETF tanks would be considered for inspection. For tanks predicted to have lower potential for
23 corrosion, inspections also are performed nonroutinely as part of the corrective maintenance program.

24 **C.4.2 Additional Requirements for New Tanks**

25 Procedures for proper installation of tanks, tank supports, piping, concrete, etc., are included in
26 *Construction Specification, Project C-018H, 242-A Evaporator/PUREX Plant Process Condensate*
27 *Treatment Facility* (WHC 1992a). For the load-in tanks, procedures are included in the construction
28 specifications in *Project W-291, 200 Area Effluent BAT/AKART Implementation ETF Truck Load-in*
29 *Facility* (KEH 1994) and *Purgewater Unloading Facility Project Documentation* (HNF 2009b).
30 Following installation, an independent, qualified, registered professional engineer inspected the tanks and
31 secondary containment. Deficiencies identified included damage to the surge tank, damage to the
32 verification tank liners, and 200 Area ETF secondary containment concrete surface cracking. All
33 deficiencies were repaired to the satisfaction of the engineer. The tanks and ancillary equipment were
34 leak tested as part of acceptance of the system from the construction contractor. Information on the
35 inspections and leak tests are included in the engineering assessment (Mausshardt 1995). No deficiencies
36 were identified during installation of the load-in tanks and ancillary equipment.

37 **C.4.3 Secondary Containment and Release Detection for Tank Systems**

38 This section describes the design and operation of secondary containment and leak detection systems at
39 the ETF.

40 **C.4.3.1 Secondary Containment Requirements for All Tank Systems**

41 The specifications for the preparation, design, and construction of the secondary containment systems at
42 the 200 Area ETF are documented (WHC 1992a). The preparation, design, and construction of the
43 secondary containment for the load-in tanks are provided in the construction specifications (KEH 1994
44 and HNF 2009b). All systems were designed to national codes and standards. Constructing the 200 Area
45 ETF per these specifications ensured that foundations are capable of supporting tank and secondary
46 containment systems and that uneven settling and failures from pressure gradients should not occur.

1 C.4.3.1.1 Common Elements

2 The following text describes elements of secondary containment that are common to all 200 Area ETF
3 tank systems. Details on the secondary containment for specific tanks, including leak detection systems
4 and liquids removal, are provided in Section 4C.4.4.1.2.

5 **Foundation and Construction.** For the tanks within the ETF, except for the sump tanks, secondary
6 containment is provided by a coated concrete floor and a 15.2-centimeter rise (berm) along the containing
7 walls. The double-wall construction of the sump tanks provides secondary containment. Additionally,
8 trenches are provided in the floor that also provides containment and drainage of any liquid to a sump pit.
9 For tanks outside the ETF, secondary containment also is provided with coated concrete floors in a
10 containment pit (load-in tanks) or surrounded by concrete dikes (the surge and verification tanks).

11 The transfer piping that carries aqueous waste into the 200 Area ETF is pipe-within-a-pipe construction,
12 and is buried approximately 1.2 meters below ground surface. The pipes between the verification tanks
13 and the verification tank pumps within the 200 Area ETF are located in a concrete pipe trench.

14 For this discussion, there are five discrete secondary containment systems associated with the following
15 tanks and ancillary equipment that treat or store dangerous waste:

- 16 • Load-in tanks
- 17 • Surge tank
- 18 • Process area (including sump tanks)
- 19 • Verification tanks
- 20 • Transfer piping and pipe trenches

21 All of the secondary containment systems are designed with reinforcing steel and base and berm thickness
22 to minimize failure caused by pressure gradients, physical contact with the waste, and climatic conditions.
23 Classical theories of structural analysis, soil mechanics, and concrete and structural steel design were used
24 in the design calculations for the foundations and structures. These calculations are maintained at the
25 ETF. In each of the analyses, the major design criteria from the following documents were included:

V-C018HC1-001	Design Construction Specification, Project C-018H, 242A Evaporator/PUREX Plant Process Condensate Treatment Facility (WHC 1992a)
DOE Order 6430.1A	General Design Criteria
SDC-4.1	Standard Architectural-Civil Design Criteria, Design Loads for Facilities (DOE-RL 1988)
UCRL-15910	Design and Evaluation Guidelines for Department of Energy Facilities Subjected to Natural Phenomena Hazards (UCRL 1987)
UBC-91	Uniform Building Code, 1991 Edition (ICBO 1991)
UBC-97	Uniform Building Code, 1997 Edition (ICC 1997, for Load-in tank 59A-TK-1)

26 The design and structural analysis calculations substantiate the structural designs in the referenced
27 drawings. The conclusions drawn from these calculations indicate that the designs are sound and that the
28 specified structural design criteria were met. This conclusion is verified in the independent design review
29 that was part of the engineering assessment (Mausshardt 1995, KEH 1994, and HNF 2009a).

30 **Containment Materials.** The concrete floor consists of cast-in-place and preformed concrete slabs. All
31 slab joints and floor and wall joints have water stops installed at the mid-depth of the slab. In addition,
32 filler was applied to each joint.

33 Except for the sump tank vaults, all of the concrete surfaces in the secondary containment system,
34 including berms, trenches, and pits, are coated with a chemical-resistant, high-solids, epoxy coating that
35 consists of a primer and a top coating. This coating material is compatible with the waste being treated,
36 and with the sulfuric acid, sodium hydroxide, and hydrogen peroxide additives to the process. The
37 coating protects the concrete from contact with any chemical materials that might be harmful to concrete
38 and prevents the concrete from being in contact with waste material. Table C.8 summarizes the specific

1 types of primer and top coats specified for the concrete and masonry surfaces in the ETF. The epoxy
2 coating is considered integral to the secondary containment system for the tanks and ancillary equipment.

3 The concrete containment systems are maintained such that any cracks, gaps, holes, and other
4 imperfections are repaired in a timely manner. Thus, the concrete containment systems do not allow
5 spilled liquid to reach soil or groundwater. There are a number of personnel doorways and vehicle access
6 points into the 200 Area ETF process areas. Releases of any spilled or leaked material to the environment
7 from these access points are prevented by 15.2-centimeter concrete curbs, sloped areas of the floor
8 (e.g., truck ramp), or trenches.

9 **Containment Capacity and Maintenance.** Each of these containment areas is designed to contain more
10 than 100 percent of the volume of the largest tank in each respective system. Secondary containment
11 systems for the surge tank, and the verification tanks, which are outside the ETF, also are large enough to
12 include the additional volume from a 25-year, 24-hour storm event; i.e., 5.3 centimeters of precipitation.

13 **Sprinkler System.** The sprinkler system within the 200 Area ETF supplies firewater protection to the
14 process area and the container storage area. This system is connected to a site wide water supply system
15 and has the capacity to supply sufficient water to suppress a fire at the ETF. However, in the event of
16 failure, the sprinkler system can be hooked up to another water source (e.g., tanker truck).

17 **C.4.3.1.2 Specific Containment Systems**

18 The following discussion presents a description of the individual containment systems associated with
19 specific tank systems.

20 **Load-In Tank Secondary Containment.** The load-in tanks 59A-TK-109 and -117 are mounted on a 46-
21 centimeter-thick reinforced concrete slab (Drawing H-2-817970). Secondary containment is provided by
22 a pit with 30.5-centimeter-thick walls and a floor constructed of reinforced concrete. The load-in tank pit
23 is sloped to drain solution to a sump. The depth of the pit varies with the slope of the floor, with an
24 average thickness of about 1.1 meters. The volume of the secondary containment is about 73,000 liters,
25 which is capable of containing the volume of at least one load-in tank (i.e., 34,200 liters). Leaks are
26 detected by a leak detector that alarms locally, in the 200 Area ETF control room, and by visual
27 inspection of the secondary containment. Alarms are monitored continuously in the ETF control room
28 during Load-in Station transfers and at least daily when there are no Load-in Station transfers occurring.

29 Adjacent to the pit is a 25.4-centimeter-thick reinforced concrete pad that serves as secondary
30 containment for the load-in tanker trucks, containers, transfer pumps, and filter system that serve as the
31 first tanker truck unloading bay. The pad is inside the metal Load-in building and is 15.2 centimeters
32 below grade with north and south walls gently sloped to allow truck access. The pad has a 3-inch drain
33 pipe to route waste solution to the adjacent load-in tank pit. The pad does not have protective coating
34 because it would experience excessive wear from the vehicle traffic.

35 Load-in tank 59A-TK-1 is located on a 25.4-centimeter-thick reinforced concrete slab (Drawing H-2-
36 817970) inside the metal Load-in building. The tank has a flat bottom which sits on a concrete slab in the
37 secondary containment. Secondary containment for the tank, filter system, and truck unloading piping is
38 provided by an epoxy coated catch basin with a capacity of about 3,400 liters. The catch basin is sloped
39 to route solution from the catch basin through a 15.2-centimeter-wide by 14.3-centimeter-deep trench to
40 the adjacent truck unloading pad. This pad drains to the Load-in tank pit discussed above. The volume of
41 the combined secondary containment of these two systems is greater than 76,400 liters, which is capable
42 of holding the volume of tank 59A-TK-1 (i.e., 26,000 liters).

43 Adjacent to tank 59A-TK-1 catch basin is a 25.4-centimeter-thick reinforced concrete pad that serves as
44 the second tanker truck unloading bay. The pad is inside the metal Load-in building and has a 2.4-meter
45 by 4.0-meter shallow, sloping pit to catch leaks during tanker truck unloading. The pit has a maximum
46 depth of 6.0 centimeters and a 15.2-centimeter-wide by 6.0-centimeter-deep trench to route leaks to the
47 adjacent tank 59A-TK-1 catch basin. The pad does not have protective coating because it would
48 experience excessive wear from the vehicle traffic.

1 **Surge Tank Secondary Containment.** The surge tank is mounted on a reinforced concrete ringwall.
2 Inside the ringwall, the flat-bottomed tank is supported by a bed of compacted sand and gravel with a
3 high-density polyethylene liner bonded to the ringwall. The liner prevents galvanic corrosion between the
4 soil and the tank. The secondary containment is reinforced concrete with a 15.2-centimeter thick floor
5 and a 20.3-centimeter thick dike. The secondary containment area shares part of the southern wall of the
6 main process area. The dike extends up 2.9 meters to provide a containment volume of 856,000 liters for
7 the 462,000-liter surge tank.

8 The floor of the secondary containment slopes to a sump in the northwest corner of the containment area.
9 Leaks into the secondary containment are detected by level instrumentation in the sump which alarms in
10 the ETF control room and/or by routine visual inspections. Sump alarms are monitored continuously in
11 the ETF control room during ETF processing operations and at least daily when ETF is not processing
12 waste. A sump pump is used to transfer solution in the secondary containment to a sump tank.

13 **Process Area Secondary Containment.** The process area contains the tanks and ancillary equipment of
14 the primary and secondary treatment trains, and has a jointed, reinforced concrete slab floor. The
15 concrete floor of the process area provides the secondary containment. This floor is a minimum of
16 15.2 centimeters thick. With doorsills 15.2 centimeter high, the process area has a containment volume of
17 approximately 93,800 liters. The largest tanks in the process area are the secondary waste receiving
18 tanks, which each have a maximum capacity of 73,800 liters.

19 The floor of the process area is sloped to drain liquids to two trenches that drain to a sump. Each trench is
20 approximately 38.1 centimeters wide with a sloped trough varying from 39.4 to 76.2 centimeters deep.
21 Leaks into the secondary containment are detected by routine visual inspections of the floor area near the
22 tanks, ancillary equipment, and in the trenches.

23 A small dam was placed in the trench that comes from the thin film dryer room to contain minor liquid
24 spills originating in the dryer room to minimize the spread of contamination into the process area. The
25 dryer room is inspected for leaks in accordance with the inspection schedule in Addendum I. Operators
26 clean up these minor spills by removing the liquid waste and decontaminating the spill area.

27 A small dam was also placed in the trench adjacent to the chemical feed skid when the chemical berm
28 area was expanded to accommodate acid and caustic pumps, which were moved indoors from the top of
29 the surge tank to resolve a safety concern. This dam was designed to contain minor spills originating in
30 the chemical berm area and prevent them from entering the process sump.

31 The northwest corner of the process area consists of a pump pit containing the pumps and piping for
32 transferring treated effluent from the verification tanks to SALDS. The pit is built 1.37 meters below the
33 process area floor level and is sloped to drain to a trench built along its north wall that routes liquid to
34 sump tank 1. Leaks into the secondary containment of the pump pit are detected by routine visual
35 inspections.

36 **Sump Tanks.** The sump tanks support the secondary containment system, and collect waste from several
37 sources, including:

- 38 • Process area drain trenches
- 39 • Tank overflows and drains
- 40 • Container washing water
- 41 • Resin dewatering solution
- 42 • Steam boiler blow down
- 43 • Sampler system drains.

44 These double-contained tanks are located within unlined, concrete vaults. The sump tank levels are
45 monitored by remote level indicators or through visual inspections from the sump covers. These
46 indicators are connected to high- and low-level alarms that are monitored in the ETF control room during
47 ETF processing operations and at least daily when ETF is not processing liquid waste. When a high-
48 level alarm is activated, a pump is activated and the sump tank contents usually are routed to the

1 secondary treatment train for processing. The contents also could be routed to the surge tank for
2 treatment in the primary treatment train. In the event of an abnormally high inflow rate, a second sump
3 pump is initiated automatically.

4 **Verification Tank Secondary Containment.** The three verification tanks are each mounted on
5 ringwalls with high-density polyethylene liners similar to the surge tank. The secondary containment for
6 the three tanks is reinforced concrete with a 15.2-centimeter thick floor and a 20.3-centimeter thick dike.
7 The dike extends up 2.6 meters to provide a containment of approximately 3,390,000 liters exceeding the
8 capacity of a single verification tank (See Table C.5).

9 The floor of the secondary containment slopes to a sump along the southern wall of the dike. Leaks into
10 the secondary containment are detected by level instrumentation in the sump and/or by routine visual
11 inspections. Sump alarms are monitored continuously in the ETF control room during ETF processing
12 operations and at least daily when ETF is not processing waste. A sump pump is used to transfer solution
13 in the secondary containment to a sump tank.

14 **C.4.3.2 Additional Requirements for Specific Types of Systems**

15 This section addresses additional requirements in [WAC 173-303-640](#) for double-walled tanks like the
16 sump tanks and secondary containment for ancillary equipment and piping associated with the tank
17 systems.

18 **C.4.3.2.1 Double-Walled Tanks**

19 The sump tanks are the only tanks in the 200 Area ETF classified as 'double-walled' tanks. These tanks
20 are located in unlined concrete vaults and support the secondary containment system for the process area.
21 The sump tanks are equipped with a leak detector between the walls of the tanks that provide continuous
22 monitoring for leaks. The leak detector alarms are monitored in the ETF control room. These sump tank
23 alarms are monitored continuously during ETF processing operations and at least daily when ETF is not
24 processing waste. The inner tanks are contained completely within the outer shells. The tanks are
25 contained completely within the concrete structure of the 200 Area ETF so corrosion protection from
26 external galvanic corrosion is not necessary.

27 **C.4.3.2.2 Ancillary Equipment**

28 The secondary containment provided for the tanks and process systems also serves as secondary
29 containment for the ancillary equipment associated with these systems.

30 **Ancillary Equipment.** Section D.4.3.1.2 describes the secondary containment systems that also serve
31 most of the ancillary equipment within the 200 Area ETF. Between the 200 Area ETF and the
32 verification tanks, a pipeline trench provides secondary containment for four pipelines connecting the
33 transfer pumps (i.e., discharge and return pumps) in the 200 Area ETF with the verification tanks
34 (Figure C.2). This concrete trench crosses under the road and extends from the verification tank pumps to
35 the verification tanks. Treated effluent flows through these pipelines from the verification tank pumps to
36 the verification tanks. The return pump is used to return effluent to the 200 Area ETF for use as service
37 water or for reprocessing.

38 For all of the ancillary equipment housed within the ETF, the concrete floor, trenches, and berms form the
39 secondary containment system. For the ancillary equipment of the surge tank and the verification tanks,
40 secondary containment is provided by the concrete floors and dikes associated with these tanks. The
41 concrete floor and pit provide secondary containment for the ancillary equipment of the load-in tanks.

42 **Transfer Piping and Pipe Trenches.** The two buried transfer lines between LERF and the surge tank
43 have secondary containment in a pipe-within-a-pipe arrangement. The 4-inch transfer line has an 8-inch
44 outer pipe, while the 3-inch transfer line has a 6-inch outer pipe. The pipes are fiberglass and are sloped
45 towards the surge tank. The outer piping ends with a drain valve in the surge tank secondary
46 containment.

1 These pipelines are equipped with leak detection located in the annulus between the inner and outer pipes;
2 the leak detection equipment can continuously 'inspect' the pipelines during aqueous waste transfers. The
3 alarms on the leak detection system are monitored in the ETF control room. The control room alarms are
4 monitored continuously during aqueous waste transfers between LERF and the ETF surge tank and at
5 least daily when no transfers are occurring. A low-volume air purge of the annulus is provided to prevent
6 condensation buildup and minimize false alarms by the leak detection system. In the event that these leak
7 detectors are not in service, the pipelines are inspected during transfers by opening a drain valve to check
8 for solution in the annular space between the inner and outer pipe.

9 The 3-inch transfer line between the load-in tanks and the surge tank has a 6-inch outer pipe in a pipe-
10 within-a-pipe arrangement. The piping is made of fiberglass-reinforced plastic and slopes towards the
11 load-in tank secondary containment pit. The drain valve and leak detection system for the load-in tank
12 pipelines are operated similarly to the leak detection system for the LERF to 200 Area ETF pipelines.

13 As previously indicated, a reinforced concrete pipe trench provides secondary containment for piping
14 under the roadway between the 200 Area ETF and the verification tanks. Three 15.2 centimeter thick
15 reinforced concrete partitions divide the trench into four portions and support metal gratings over the
16 trench. Each portion of the trench is 1.2 meters wide, 0.76 meter deep, and slopes To route any solution
17 present to 4-inch drain lines through the north wall of the ETF building. These drain lines route solution
18 to sump tank 2 in ETF. The floor of the pipe trench is 30.5 centimeters thick and the sides are
19 15.2 centimeters thick. The concrete trenches are coated with water sealant and covered with metal
20 gratings at ground level to allow vehicle traffic on the roadway.

21 **C.4.4 Tank Management Practices**

22 When an aqueous waste stream is identified for treatment or storage at 200 Area ETF, the generating unit
23 is required to characterize the waste. Based on characterization data, the waste stream is evaluated to
24 determine if the stream is acceptable for treatment or storage. Specific tank management practices are
25 discussed in the following sections.

26 **C.4.4.1 Rupture, Leakage, Corrosion Prevention**

27 Most aqueous waste streams can be managed such that corrosion would not be a concern. For example,
28 an aqueous waste stream with high concentrations of chloride might cause corrosion problems when
29 concentrated in the secondary treatment train. One approach is to adjust the corrosion control measures in
30 the secondary treatment train. An alternative might be to blend this aqueous waste in a LERF basin with
31 another aqueous waste that has sufficient dissolved solids, such that the concentration of the chlorides in
32 the secondary treatment train would not pose a corrosion concern.

33 Additionally, the materials of construction used in the tanks systems (Table C.5) make it unlikely that an
34 aqueous waste would corrode a tank. For more information on corrosion prevention, refer to
35 Addendum B, Waste Analysis Plan.

36 If operating experience suggests that most aqueous waste streams can be managed such that corrosion
37 would not be a concern, operating practices and integrity assessment schedules and requirements will be
38 reviewed and modified as appropriate.

39 When a leak in a tank system is discovered, the leak is immediately contained or stopped by isolating the
40 leaking component. Following containment, the requirements of [WAC 173-303-640\(7\)](#), incorporated by
41 reference, are followed. These requirements include repair or closure of the tank/tank system component,
42 and certification of any major repairs.

43 **C.4.4.2 Overfilling Prevention**

44 Operating practices and administrative controls used at the 200 Area ETF to prevent overfilling a tank are
45 discussed in the following paragraphs. The 200 Area ETF process is controlled by the MCS. The MCS
46 monitors liquid levels in the 200 Area ETF tanks and has alarms that annunciate on high-liquid level to
47 notify operators that actions must be taken to prevent overfilling of these vessels. As an additional

1 precaution to prevent spills, many tanks are equipped with overflow lines that route solutions to sump
2 tanks 1 and 2. These tanks include the pH adjustment tank; RO feed tanks, effluent pH adjustment tank,
3 secondary waste receiving tanks, and concentrate tanks.

4 The following section discusses feed systems, safety cutoff devices, bypass systems, and pressure
5 controls for specific tanks and process systems.

6 **Tanks.** All tanks are equipped with liquid level sensors that give a reading of the tank liquid volume. All
7 of the tanks are equipped further with liquid level alarms that are actuated if the liquid volume is near the
8 tank overflow capacity. In the actuation of the surge tank alarm, a liquid level switch trips, sending a
9 signal to the valve actuator on the tank influent lines, and causing the influent valves to close.

10 The operating mode for each verification tank, i.e., receiving, holding, or discharging, can be designated
11 through the MCS; modes also switch automatically. When the high-level set point on the receiving
12 verification tank is reached, the flow to this tank is diverted and another tank becomes the receiver. The
13 full tank is switched into verification mode. The third tank is reserved for discharge mode.

14 The liquid levels in the pH adjustment, first and second RO feed, and effluent pH adjustment tanks are
15 maintained within predetermined operating ranges. Should any of these tanks overflow, the excess waste
16 is piped along with any leakage from the feed pumps to a sump tank.

17 When waste in a secondary waste-receiving tank reaches the high-level set point, the influent flow of
18 waste is redirected to the second tank. In a similar fashion, the concentrate tanks switch receipt modes
19 when the high-level set point of one tank is reached.

20 **Filter Systems.** All filters at 200 Area ETF (i.e., the Load-In Station, rough, fine, and auxiliary filter
21 systems) are in leak-tight steel casings. For the rough and fine filters, a high differential pressure, which
22 could damage the filter element, activates a valve that shuts off liquid flow to protect the filter element
23 from possible damage. To prevent a high-pressure situation, the filters are cleaned routinely with pulses
24 of compressed air that force water back through the filter. Cleaning is terminated automatically by
25 shutting off the compressed air supply if high pressure develops. The differential pressure across the
26 auxiliary filters also is monitored. A high differential pressure in these filters would result in a system
27 shutdown to allow the filters to be changed out.

28 The Load-In Station filtration system has pressure gauges for monitoring the differential pressure across
29 each filter. A high differential pressure would result in discontinuing filter operation until the filter is
30 replaced.

31 **Ultraviolet Light/Oxidation System and Decomposers.** A rupture disk on the inlet piping to each of
32 the UV/OX reaction vessels relieves to the pH adjustment tank in the event of excessive pressure
33 developing in the piping system. Should the rupture disk fail, the aqueous waste would trip the moisture
34 sensor, shut down the UV lamps, and close the surge tank feed valve. Also provided is a level sensor to
35 protect UV lamps against the risk of exposure to air. Should those sensors be actuated, the UV lamps
36 would be shut down immediately.

37 The piping and valving for the hydrogen peroxide decomposers are configured to split the waste flow:
38 half flows to one decomposer and half flows to the other decomposer. Alternatively, the total flow of
39 waste can be treated in one decomposer or both decomposers can be bypassed. A safety relief valve on
40 each decomposer vessel can relieve excess system pressure to a sump tank.

41 **Degasification System.** The degasification column is typically supplied aqueous waste feed by the pH
42 adjustment tank feed pump. This pump transfers waste solution through the hydrogen peroxide
43 decomposer, the fine filter, and the degasification column to the first RO feed tank.

44 The degasification column is designed for operation at a partial vacuum. A pressure sensor in the outlet
45 of the column detects the column pressure. The vacuum in the degasification column is maintained by a
46 blower connected to the vessel off gas system. The column is protected from extremely low pressure
47 developed by the column blower by the use of an intake vent that is maintained in the open position

1 during operation. The column liquid level is regulated by a flow control system with a high- and low-
2 level alarm. Plate-type heat exchanger cools the waste solution fed to the degasification column.

3 **Reverse Osmosis System.** The flow through the first and second RO stages is controlled to maintain
4 constant liquid levels in the first and second stage RO feed tanks.

5 **Polisher.** Typically, two of the three columns are in operation (lead/lag) and the third (regenerated)
6 column is in standby. When the capacity of the resin in the first column is exceeded, as detected by an
7 increase in the conductivity of the column effluent, the third column, containing freshly regenerated IX
8 resin, is brought online. The first column is taken offline, and the waste is rerouted to the second column,
9 and to the third. Liquid level instrumentation and automatically operated valves are provided in the IX
10 system to prevent overflowing.

11 **Effluent Treatment Facility Evaporator.** Liquid level instrumentation in the secondary waste receiving
12 tanks is designed to preclude a tank overflow. A liquid level switch actuated by a high-tank liquid level
13 causes the valves to reposition, closing off flow to the secondary waste receiving tanks. Secondary
14 containment for these tanks routes liquids to a sump tank.

15 Valves in the 200 Area ETF evaporator feed line can be positioned to bypass the secondary waste around
16 the 200 Area ETF evaporator and to transfer the secondary waste to the concentrate tanks.

17 **Thin Film Dryer.** The two concentrate tanks alternately feed the thin film dryer. Typically, one tank
18 serves as a concentrate waste receiver while the other tank serves as the dryer feed tank. One tank may
19 serve as both concentrate waste receiver and dryer feed tank. Liquid level instrumentation prevents tank
20 overflow by diverting the concentrate flow from the full concentrate tank to the other concentrate tank.
21 Secondary containment for these tanks routes liquids to a sump tank.

22 An alternate route is provided from the concentrate receiver tank to the secondary waste receiving tanks.
23 Dilute concentrate in the concentrate receiver tank can be reprocessed through the 200 Area ETF
24 evaporator by transferring the concentrate back to a secondary waste-receiving tank.

25 **C.4.5 Labels or Signs**

26 Each tank or process unit in the 200 Area ETF is identified by a nameplate attached in a readily visible
27 location. Included on the nameplate are the equipment number and the equipment title. Those tanks that
28 store or treat dangerous waste at the 200 Area ETF (Section 4C.4.1.1) are identified with a label, which
29 reads *PROCESS WATER/WASTE*. The labels are legible at a distance of at least fifty feet or as
30 appropriate for legibility within the ETF. Additionally, these tanks bear a legend that identifies the waste
31 in a manner, which adequately warns employees, emergency personnel, and the public of the major risk(s)
32 associated with the waste being stored or treated in the tank system(s).

33 Caution plates are used to show possible hazards and warn that precautions are necessary. Caution signs
34 have a yellow background and black panel with yellow letters and bear the word *CAUTION*. Danger
35 signs show immediate danger and signify that special precautions are necessary. These signs are red,
36 black, and white and bear the word *DANGER*.

37 Tanks and vessels containing corrosive chemicals are posted with black and white signs bearing the word
38 *CORROSIVE*. *DANGER - UNAUTHORIZED PERSONNEL KEEP OUT* signs are posted on all exterior
39 doors of the ETF, and on each interior door leading into the process area. Tank ancillary piping is also
40 labeled *PROCESS WATER* or *PROCESS LIQUID* to alert personnel which pipes in the process area
41 contains dangerous and/or mixed waste.

42 All tank systems holding dangerous waste are marked with labels or signs to identify the waste contained
43 in the tanks. The labels or signs are legible at a distance of at least 50-feet and bear a legend that
44 identifies the waste in a manner that adequately warns employees, emergency response personnel, and the
45 public, of the major risk(s) associated with the waste being stored or treated in the tank system(s).

1 **C.4.6 Air Emissions**

2 Tank systems that contain extremely hazardous waste that is acutely toxic by inhalation must be designed
3 to prevent the escape of such vapors. To date, no extremely hazardous waste has been managed in
4 200 Area ETF tanks and is not anticipated. However, the 200 Area ETF tanks have forced ventilation that
5 draws air from the tank vapor spaces to prevent exposure of operating personnel to any toxic vapors that
6 might be present. The vapor passes through a charcoal filter and two sets of high-efficiency particulate
7 air filters before discharge to the environment. The Load-in tanks and verification tanks are vented to the
8 atmosphere.

9 **C.4.7 Management of Ignitable or Reactive Wastes in Tanks Systems**

10 Although the 200 Area ETF is permitted to accept waste that is designated ignitable or reactive, such
11 waste would be treated or blended immediately after placement in the tank system so that the resulting
12 waste mixture is no longer ignitable or reactive. Aqueous waste received does not meet the definition of a
13 combustible or flammable liquid given in National Fire Protection Association (NFPA) code number
14 30 (NFPA 1996). The buffer zone requirements in NFPA-30, which require tanks containing combustible
15 or flammable solutions be a safe distance from each other and from public way, are not applicable.

16 **C.4.8 Management of Incompatible Wastes in Tanks Systems**

17 The 200 Area ETF manages dilute solutions that can be mixed without compatibility issues. The
18 200 Area ETF is equipped with several systems that can adjust the pH of the waste for treatment
19 activities. Sulfuric acid and sodium hydroxide are added to the process through the MCS for pH
20 adjustment to ensure there will be no large pH fluctuations and adverse reactions in the tank systems.

21 **C.5 SURFACE IMPOUNDMENTS**

22 This section provides specific information on surface impoundment operations at the LERF, including
23 descriptions of the liners and secondary containment structures, as required by [WAC 173-303-650](#) and
24 [WAC 173-303-806\(4\)\(d\)](#).

25 The LERF consists of three lined surface impoundments (basins) with a design operating capacity of
26 29.5 million liters each. The maximum capacity of each basin is 34 million liters. The dimensions of
27 each basin at the anchor wall are approximately 103 meters by 85 meters. The typical top dimensions of
28 the wetted area are approximately 89 meters by 71 meters, while the bottom dimensions are
29 approximately 57 by 38 meters. Total depth from the top of the dike to the bottom of the basin is
30 approximately 7 meters. The typical finished basin bottoms lie at about 4 meters below the initial grade
31 and 175 meters above sea level. The dikes separating the basins have a typical height of 3 meters and
32 typical top width of 11.6 meters around the perimeter of the impoundments.

33 **C.5.1 List of Dangerous Waste**

34 A list of dangerous and/or mixed aqueous waste that can be stored in LERF is presented in Addendum A.
35 Addendum B, Waste Analysis Plan also provides a discussion of the types of waste that are managed in
36 the LERF.

37 **C.5.2 Construction, Operation, and Maintenance of Liner System**

38 General information concerning the liner system is presented in the following sections. Information
39 regarding loads on the liner, liner coverage, UV light exposure prevention, and location relative to the
40 water table are discussed.

41 **C.5.2.1 Liner Construction Materials**

42 The LERF employs a double-composite liner system with a leachate detection, collection, and removal
43 system between the primary and secondary liners. Each basin is constructed with an upper or primary
44 liner consisting of a high-density polyethylene geomembrane laid over a bentonite carpet liner. The lower
45 or secondary liner in each basin is a composite of a geomembrane laid over a layer of soil/bentonite
46 admixture with a hydraulic conductivity less than 10^{-7} centimeters per second. The synthetic liners extend

1 up the dike wall to a concrete anchor wall that surrounds the basin at the top of the dike. A batten system
2 bolts the layers in place to the anchor wall (Figure C.16).

3 Figure C.17 is a schematic cross-section of the liner system. The liner components, listed from the top to
4 the bottom of the liner system, are the following:

- 5 • Primary 1.5-millimeter high-density polyethylene geomembrane
- 6 • Bentonite carpet liner
- 7 • Geotextile
- 8 • Drainage gravel (bottom) and geonet (sides)
- 9 • Geotextile
- 10 • Secondary 1.5-millimeter high-density polyethylene geomembrane
- 11 • Soil/bentonite admixture (91 centimeters on the bottom, 107 centimeters on the sides)
- 12 • Geotextile

13 The primary geomembrane, made of 1.5-millimeter high-density polyethylene, forms the basin surface
14 that holds the aqueous waste. The secondary geomembrane, also 1.5-millimeter high-density
15 polyethylene, forms a barrier surface for leachate that might penetrate the primary liner. The high-density
16 polyethylene chemically is resistant to constituents in the aqueous waste and has a relatively high strength
17 compared to other lining materials. The high-density polyethylene resin specified for the LERF contains
18 carbon black, antioxidants, and heat stabilizers to enhance its resistance to the degrading effects of UV
19 light. The approach to ensuring the compatibility of aqueous waste streams with the LERF liner materials
20 and piping is discussed in Addendum B, Waste Analysis Plan.

21 Three geotextile layers are used in the LERF liner system. The layers are thin, nonwoven polypropylene
22 fabric that chemically is resistant, highly permeable, and resistant to microbiological growth. The first
23 two layers prevent fine soil particles from infiltrating and clogging the drainage layer. The second
24 geotextile also provides limited protection for the secondary geomembrane from the drainage rock. The
25 third geotextile layer prevents the mixing of the soil/bentonite admixture with the much more porous and
26 granular foundation material.

27 A 30.5-centimeters-thick gravel drainage layer on the bottom of the basins between the primary and
28 secondary liners provides a flow path for liquid to the leachate detection, collection, and removal system.
29 A geonet (or drainage net) is located immediately above the secondary geomembrane on the basin
30 sidewalls. The geonet functions as a preferential flow path for liquid between the liners, carrying liquid
31 down to the gravel drainage layer and subsequently to the leachate sump. The geonet is a mesh made of
32 high-density polyethylene, with approximately 13-millimeter openings.

33 The soil/bentonite layer is 91 centimeters thick on the bottom of the basins and 107 centimeters thick on
34 the basin sidewalls; its permeability is less than 10^{-7} centimeters per second. This composite liner design,
35 consisting of a geomembrane laid over essentially impermeable soil/bentonite, is considered best
36 available technology for solid waste landfills and surface impoundments. The combination of synthetic
37 and clay liners is reported in the literature to provide the maximum protection from waste migration
38 (Forseth and Kmet 1983).

39 A number of laboratory tests were conducted to measure the engineering properties of the soil/bentonite
40 admixture, in addition to extensive field tests performed on three test fills constructed near the LERF site.
41 For establishing an optimum ratio of bentonite to soil for the soil/bentonite admixture, mixtures of various
42 ratios were tested to determine permeability and shear strength. A mixture of 12 percent bentonite was
43 selected for the soil/bentonite liner and tests described in the following paragraphs demonstrated that the
44 admixture meets the desired permeability of less than 10^{-7} centimeters per second. Detailed discussion of
45 test procedures and results is provided in Report of Geotechnical Investigation, 242-A Evaporation and
46 PUREX Interim Storage Basins (Chen-Northern 1990).

47 Direct shear tests were performed according to ASTM D3080 test procedures (ASTM 1990) on
48 soil/bentonite samples of various ratios. Based on these results, the conservative minimum Mohr-

1 Coulomb shear strength value of 30 degrees was estimated for a soil/bentonite admixture containing
2 12 percent bentonite.

3 The high degree of compaction of the soil/bentonite layer [92 percent per ASTM D1557 (ASTM 1991)]
4 was expected to maximize the bonding forces between the clay particles, thereby minimizing moisture
5 transport through the liner. With respect to particle movement ('piping'), estimated fluid velocities in this
6 low-permeability material are too low to move the soil particles. Therefore, piping is not considered a
7 problem.

8 For the soil/bentonite layer, three test fills were constructed to demonstrate that materials, methods, and
9 procedures used would produce a soil/bentonite liner that meets the EPA permeability requirement of less
10 than 10^{-7} centimeters per second. All test fills met the EPA requirements. A thorough discussion of
11 construction procedures, testing, and results is provided in *Report of Permeability Testing, Soil-bentonite*
12 *Test Fill* (Chen-Northern 1991a).

13 The aqueous waste stored in the LERF is typically a dilute mixture of organic and inorganic constituents.
14 Though isolated instances of soil liner incompatibility have been documented in the literature (Forseth
15 and Kmet 1983), these instances have occurred with concentrated solutions that were incompatible with
16 the geomembrane liners in which the solutions were contained. Considering the dilute nature of the
17 aqueous waste that is and will be stored in LERF and the moderate pH, and test results demonstrating the
18 compatibility of the high-density polyethylene liners with the aqueous waste [9090 Test Results
19 (WHC 1991)], gross failure of the soil/bentonite layer is not probable.

20 Each basin also is equipped with a floating very low-density polyethylene cover. The cover is anchored
21 and tensioned at the concrete wall at the top of the dikes, using a patented mechanical tensioning system.
22 Figure C.16 depict the tension mechanism and the anchor wall at the perimeter of each basin. Additional
23 information on the cover system is provided in Section C.5.2.5.

24 **C.5.2.1.1 Material Specifications**

25 Material specifications for the liner system and leachate collection system, including liners, drainage
26 gravel, and drainage net are discussed in the following sections. Material specifications are documented
27 in the *Final Specifications 242-A Evaporator and PUREX Interim Retention Basins* (KEH 1990a) and
28 *Construction Specifications for 242-A Evaporator and PUREX Interim Retention Basins* (KEH 1990b).

29 **Geomembrane Liners.** The high-density polyethylene resin for geomembranes for the LERF meets the
30 material specifications listed in Table C.9. Key physical properties include thickness (1.5 millimeters
31 [60 mil]) and impermeability (hydrostatic resistance of over 360,000 kilogram per square meter).
32 Physical properties meet National Sanitation Foundation Standard 54 (NSF 1985). Testing to determine
33 if the liner material is compatible with typical dilute waste solutions was performed and documented in
34 *9090 Test Results* (WHC 1991).

35 **Soil/Bentonite Liner.** The soil/bentonite admixture consists of 11.5 to 14.5 percent bentonite mixed into
36 well-graded silty sand with a maximum particle size of 4.75 millimeters (No. 4 sieve). Test fills were
37 performed to confirm the soil/bentonite admixture applied at LERF has hydraulic conductivity less than
38 10^{-7} centimeters per second, as required by [WAC 173-303-650\(2\)\(j\)](#) for new surface impoundments.

39 **Bentonite Carpet Liner.** The bentonite carpet liner consists of bentonite (90 percent sodium
40 montmorillonite clay) in a primary backing of woven polypropylene with nylon filler fiber, and a cover
41 fabric of open weave spunlace polyester. The montmorillonite is anticipated to retard migration of
42 solution through the liner, exhibiting a favorable cation exchange for adsorption of some constituents
43 (such as ammonium). Based on composition of the bentonite carpet and of the type of aqueous waste
44 stored at LERF, no chemical attack, dissolution, or degradation of the bentonite carpet liner is anticipated.

45 **Geotextile.** The nonwoven geotextile layers consist of long-chain polypropylene polymers containing
46 stabilizers and inhibitors to make the filaments resistant to deterioration from UV light and heat exposure.
47 The geotextile layers consist of continuous geotextile sheets held together by needle punching. Edges of

1 the fabric are sealed or otherwise finished to prevent outer material from pulling away from the fabric or
2 raveling.

3 **Drainage Gravel.** The drainage layer consists of thoroughly washed and screened, naturally occurring
4 rock meeting the size specifications for Grading Number 5 in Washington State Department of
5 Transportation construction specifications (WSDOT 1988). The specifications for the drainage layer are
6 given in Table C.10. Hydraulic conductivity tests (Chen-Northern 1992a, 1992b, 1992c) showed the
7 drainage rock used at LERF met the sieve requirements and had a hydraulic conductivity of at least
8 1 centimeter per second, which exceeded the minimum of at least 0.1 centimeters per second required by
9 [WAC 173-303-650\(2\)\(j\)](#) for new surface impoundments.

10 **Geonet.** The geonet is fabricated from two sets of parallel high-density polyethylene strands, spaced
11 1.3 centimeters center-to-center maximum to form a mesh with minimum two strands per 2.54 centimeter
12 in each direction. The geonet is located between the liners on the sloping sidewalls to provide a
13 preferential flow path for leachate to the drainage gravel and subsequently to the leachate sump.

14 **Leachate Collection Sump.** Materials used to line the 3.0-meter by 1.8-meter by 0.30-meter-deep
15 leachate sump, at the bottom of each basin in the northwest corner, include [from top to bottom
16 (Figure C.18)]:

- 17 • 25 millimeter high-density polyethylene flat stock (supporting the leachate riser pipe)
- 18 • Geotextile
- 19 • 1.5-millimeter high-density polyethylene rub sheet
- 20 • Secondary composite liner:
 - 21 – 1.5-millimeter high-density polyethylene geomembrane
 - 22 – 91 centimeters of soil/bentonite admixture
 - 23 – Geotextile

24 Specifications for these materials are identical to those discussed previously.

25 **Leachate System Risers.** Risers for the leachate system consist of 10-inch and 4-inch pipes from the
26 leachate collection sump to the catch basin northwest of each basin (Figure C.18). The risers lay below
27 the primary liner in a gravel-filled trench that also extends from the sump to the concrete catch basin
28 (Figure C.19).

29 The risers are high-density polyethylene pipes fabricated to meet the requirements in ASTM D1248
30 (ASTM 1989). The 10-inch riser is perforated every 20.3 centimeters with 1.3-centimeter holes around
31 the diameter. Level sensors and leachate pump are inserted in the 10-inch riser to monitor and remove
32 leachate from the sump. To prevent clogging of the pump and piping with fine particulate, the end of the
33 riser is encased in a gravel-filled box constructed of high-density polyethylene geonet and wrapped in
34 geotextile. The 4-inch riser is perforated every 10.2 centimeters with 0.64-centimeter holes around the
35 diameter. A level detector is inserted in the 4-inch riser.

36 **Leachate Pump.** A deep-well submersible pump, designed to deliver approximately 110 liters per
37 minute, is installed in the 10-inch leachate riser in each basin. Wetted parts of the leachate pump are
38 made of 316L stainless steel, providing both corrosion resistance and durability.

39 **C.5.2.1.2 Loads on Liner System**

40 The LERF liner system is subjected to the following types of stresses.

41 **Stresses from Installation or Construction Operations.** Contractors were required to submit
42 construction quality control plans that included procedures, techniques, tools, and equipment used for the
43 construction and care of liner and leachate system. Methods for installation of all components were
44 screened to ensure that the stresses on the liner system were kept to a minimum.

45 Calculations were performed to estimate the risk of damage to the secondary high-density polyethylene
46 liner during construction (*Calculations for LERF Part B Permit Application* [HNF 1997]). The greatest
47 risk expected was from spreading the gravel layer over the geotextile layer and secondary geomembrane.

1 The results of the calculations show that the strength of the geotextile was sufficiently high to withstand
2 the stress of a small gravel spreader driving on a minimum of 15 centimeters of gravel over the geotextile
3 and geomembrane. The likelihood of damage to the geomembrane lying under the geotextile was
4 considered low.

5 To avoid driving heavy machinery directly on the secondary liner, a 28-meter conveyer was used to
6 deliver the drainage gravel into the basins. The gravel was spread and consolidated by hand tools and a
7 bulldozer. The bulldozer traveled on a minimum thickness of 30.5 centimeters of gravel. Where the
8 conveyer assembly was placed on top of the liner, cribbing was placed to distribute the conveyer weight.
9 No heavy equipment was allowed for use directly in contact with the geomembranes.

10 Additional calculations were performed to estimate the ability of the leachate riser pipe to withstand the
11 static and dynamic loading imposed by lightweight construction equipment riding on the gravel layer
12 (HNF 1997). Those calculations demonstrated that the pipe could buckle under the dynamic loading of
13 small construction equipment; therefore, the pipe was avoided by equipment during spreading of the
14 drainage gravel.

15 Installation of synthetic lining materials proceeded only when winds were less than 24 kilometers per
16 hour, and not during precipitation. The minimum ambient air temperature for unfolding or unrolling the
17 high-density polyethylene sheets was -10 C, and a minimum temperature of 0 C was required for seaming
18 the high-density polyethylene sheets. Between shifts, geomembranes and geotextile were anchored with
19 sandbags to prevent lifting by wind. Calculations were performed to determine the appropriate spacing of
20 sandbags on the geomembrane to resist lifting caused by 130 kilometer per hour winds (HNF 1997). All
21 of the synthetic components contain UV light inhibitors and no impairment of performance is anticipated
22 from the short-term UV light exposure during construction. Section C.5.2.4 provides further detail on
23 exposure prevention.

24 During the laying of the soil/bentonite layer and the overlying geomembrane, moisture content of the
25 admixture was monitored and adjusted to ensure optimum compaction and to avoid development of
26 cracks.

27 **C.5.2.1.3 Static and Dynamic Loads and Stresses from the Maximum Quantity of Waste**

28 When a LERF basin is full, liquid depth is approximately 6.4 meters. Static load on the primary liner is
29 roughly 6,400 kilograms per square meter. Load on the secondary liner is slightly higher because of the
30 weight of the gravel drainage layer. Assuming a density of 805 kilograms per square meter for the
31 drainage gravel [conservative estimate based on specific gravity of 2.65 (Ambrose 1988)], the secondary
32 high-density polyethylene liner carries approximately 7,200 kilograms per square meter when a basin is
33 full.

34 Side slope liner stresses were calculated for each of the layers in the basin sidewalls and for the pipe
35 trench on the northwest corner of each basin (HNF 1997). Results of these calculations indicate factors of
36 safety against shear were 1.5 or greater for the primary geomembrane, geotextile, geonet, and secondary
37 geomembrane.

38 Because the LERF is not located in an area of seismic concern, as identified in Appendix VI of
39 [40 CFR 264](#) and [WAC 173-303-282\(6\)\(a\)\(I\)](#), discussion and calculation of potential seismic events are
40 not required.

41 **C.5.2.1.4 Stresses Resulting from Settlement, Subsidence, or Uplift**

42 Uplift stresses from natural sources are expected to have negligible impact on the liner. Groundwater lies
43 approximately 62 meters below the LERF, average annual precipitation is only 16 centimeters, and the
44 average unsaturated permeability of the soils near the basin bottoms is high, ranging from about
45 5.5×10^4 centimeters per second to about 1 centimeter per second (Chen-Northern 1991b). Therefore, no
46 hydrostatic uplift forces are expected to develop in the soil underneath the basins. In addition, the soil
47 under the basins consists primarily of gravel and sand, and contains few or no organic constituents.
48 Therefore, uplift caused by gas production from organic degradation is not anticipated.

1 Based on the design of the soil-bentonite liner, no structural uplift stresses are present within the lining
2 system (Chen-Northern 1991b).

3 Regional subsidence is not anticipated because neither petroleum nor extractable economic minerals are
4 present in the strata underlying the LERF basins, nor is karst (erosive limestone) topography present.

5 Dike soils and soil/bentonite layers were compacted thoroughly and proof-rolled during construction.
6 Calculation of settlement potential showed that combined settlement for the foundation and soil/bentonite
7 layer is expected to be about 2.7 centimeters. Settlement impact on the liner and basin stability is
8 expected to be minimal (Chen-Northern 1991b).

9 **C.5.2.1.5 Internal and External Pressure Gradients**

10 Pressure gradients across the liner system from groundwater are anticipated to be negligible. The LERF
11 is about 62 meters above the seasonal high water table, which prevents buildup of water pressure below
12 the liner. The native gravel foundation materials of the LERF are relatively permeable and free draining.
13 The 2 percent slope of the secondary liner prevents the pooling of liquids on top of the secondary liner.
14 Finally, the fill rate of the basins is slow enough (average 190 liters per minute) that the load of the liquid
15 waste on the primary liner is gradually and evenly distributed.

16 To prevent the buildup of gas between the liners, each basin is equipped with 21 vents in the primary
17 geomembrane located above the maximum water level that allow the reduction of any excess gas
18 pressure. Gas passing through these vents exit through a single pipe that penetrates the anchor wall into a
19 carbon adsorption filter. This filter extracts nearly all of the organic compounds, ensuring that emissions
20 to the air from the basins are not toxic.

21 **C.5.2.2 Liner System Location Relative to High-Water Table**

22 The lowest point of each LERF basin is the northwest corner of the sump, where the typical subgrade
23 elevation is 175 meters above mean sea level. Based on data collected from the groundwater monitoring
24 wells at the LERF site, the seasonal high-water table is located approximately 62 meters or more below
25 the lowest point of the basins. This substantial thickness of unsaturated strata beneath the LERF provides
26 ample protection to the liner from hydrostatic pressure because of groundwater intrusion into the
27 soil/bentonite layer. Further discussion of the unsaturated zone and site hydrogeology is provided in
28 Addendum D, Groundwater Monitoring Plan.

29 **C.5.2.3 Liner System Foundation**

30 Foundation materials are primarily gravels and cobbles with some sand and silt. The native soils onsite
31 are derived from unconsolidated Holocene sediments. These sediments are fluvial and glaciofluvial sands
32 and gravels deposited during the most recent glacial and postglacial event. Grain-size distributions and
33 shape analyses of the sediments indicate that deposition occurred in a high-energy environment (Chen-
34 Northern 1990).

35 Analysis of five soil borings from the LERF site was conducted to characterize the natural foundation
36 materials and to determine the suitability of onsite soils for construction of the impoundment dikes and
37 determine optimal design factors. Well-graded gravel containing varying amounts of silt, sand, and
38 cobbles comprises the layer in which the basins were excavated. This gravel layer extends to depths of
39 10 to 11 meters below land surface (Chen-Northern 1990). The basins are constructed directly on the
40 subgrade. Excavated soils were screened to remove oversize cobbles (greater than 15 centimeters in the
41 largest dimension) and used to construct the dikes.

42 Settlement potential of the foundation material and soil/bentonite layer was found to be low. The
43 foundation is comprised of undisturbed native soils. The bottom of the basin excavation lies within the
44 well-graded gravel layer, and is dense to very dense. Below the gravel is a layer of dense to very dense
45 poorly graded and well-graded sand. Settlement was calculated for the gravel foundation soils and for the
46 soil/bentonite layer, under the condition of hydrostatic loading from 6.4 meters of fluid depth. The
47 combined settlement for the soils and the soil/bentonite layer is estimated to be about 2.7 centimeters.

1 This amount of settlement is expected to have minimal impact on overall liner or basin stability
2 (Chen-Northern 1991b). Settlement calculations are provided in *Calculations for Liquid Effluent*
3 *Retention Facility Part B Permit Application* (HNF 1997).

4 The load bearing capacity of the foundation material, based on the soil analysis discussed previously, is
5 estimated at about 48,800 kilograms per square meter [maximum advisable presumptive bearing capacity
6 (Hough 1969)]. Anticipated static and dynamic loading from a full basin is estimated to be less than
7 9,000 kilograms per square meter (Section C.5.2.1.3), which provides an ample factor of safety.

8 When the basins are empty, excess hydrostatic pressure in the foundation materials under the liner system
9 theoretically could result in uplift and damage. However, because the native soil forming the foundations
10 is unsaturated and relatively permeable, and because the water table is located at a considerable depth
11 beneath the basins, any infiltration of surface water at the edge of the basin is expected to travel
12 predominantly downward and away from the basins, rather than collecting under the excavation itself.
13 No gas is expected in the foundation because gas-generating organic materials are not present.

14 Subsidence of undisturbed foundation materials is generally the result of fluid extraction (water or
15 petroleum), mining, or karst topography. Neither petroleum, mineral resources, nor karst are believed to
16 be present in the sediments overlying the Columbia River basalts. Potential groundwater resources do
17 exist below the LERF. Even if these sediments were to consolidate from fluid withdrawal, their depth
18 most likely would produce a broad, gently sloping area of subsidence that would not cause significant
19 strains in the LERF liner system. Consequently, the potential for subsidence related failures are expected
20 to be negligible.

21 Borings at the LERF site, and extensive additional borings in the 200 East Area, have not identified any
22 significant quantities of soluble materials in the foundation soil or underlying sediments (Last et al. 1989).
23 Consequently, the potential for sinkholes is considered negligible.

24 **C.5.2.4 Liner System Exposure Prevention**

25 Both primary and secondary geomembranes and the floating cover are stabilized with carbon black to
26 prevent degradation from UV light. Furthermore, none of the liner layers experience long-term exposure
27 to the elements. During construction, thin polyethylene sheeting was used to maintain optimum moisture
28 content and provide protection from the wind for the soil/bentonite layer until the secondary
29 geomembrane was laid in place. The secondary geomembrane was covered by the geonet and geotextile
30 as soon as quality control testing was complete. Once the geotextile layer was completed, drainage
31 material immediately was placed over the geotextile. The final (upper) geotextile layer was placed over
32 the drainage gravel and immediately covered by the bentonite carpet liner. This was covered
33 immediately, in turn, by the primary high-density polyethylene liner.

34 Both high-density polyethylene liners, geotextile layers, and geonet are anchored permanently to a
35 concrete wall at the top of the basin berm. During construction, liners were held in place with many
36 sandbags on both the basin bottoms and side slopes to prevent wind from lifting and damaging the
37 materials. Calculations were performed to determine the amount of fluid needed in a basin to prevent
38 wind lift damage to the primary geomembrane. Approximately 15 to 20 centimeters of solution are kept
39 in each basin to minimize the potential for uplifting the primary liner (HNF 1997).

40 The entire lining system is covered by a very low-density polyethylene floating cover that is bolted to the
41 concrete anchor wall. The floating cover prevents evaporation and intrusion from dust, precipitation,
42 vegetation, animals, and birds. A patented tensioning system is employed to prevent wind from lifting the
43 cover and automatically accommodate changes in liquid level in the basins. The cover tension
44 mechanism consists of a cable running from the flexible geosynthetic cover over a pulley on the tension
45 tower (located on the concrete anchor wall) to a dead man anchor. These anchors (blocks) simply hang
46 from the cables on the exterior side of the tension towers. The anchor wall also provides for solid
47 attachment of the liner layers and the cover, using a 6.4-millimeter batten and neoprene gasket to bolt the

1 layers to the concrete wall, effectively sealing the basin from the intrusion of light, precipitation, and
2 airborne dust (Figure C.16).

3 The floating cover, made of very low-density polyethylene with UV light inhibitors, is not anticipated to
4 experience unacceptable degradation during the service life of the LERF. The very low-density
5 polyethylene material contains carbon black for UV light protection, anti-oxidants to prevent heat
6 degradation, and seaming enhancers to improve its ability to be welded. A typical manufacturer's limited
7 warranty for weathering of very low-density polyethylene products is 20 years (Poly America, undated).
8 This provides a margin of safety for the anticipated medium-term use of the LERF for aqueous waste
9 storage.

10 The upper 3.4 to 4.6 meters of the sidewall liner also could experience stresses in response to temperature
11 changes. Accommodation of thermal influences for the LERF geosynthetic layers is affected by inclusion
12 of sufficient slack as the liners were installed. Calculations demonstrate that approximately
13 67 centimeters of slack is required in the long basin bottom dimension, 46 centimeters across the basin,
14 and 34 centimeters from the bottom of the basin to the top of the basin wall (HNF 1997).

15 Thermal stresses also are experienced by the floating cover. As with the geomembranes, sufficient slack
16 was included in the design to accommodate thermal contraction and expansion.

17 **C.5.2.4.1 Liner Repairs During Operations**

18 Should repair of a basin liner be required while the basin is in operation, a sufficient quantity of the basin
19 contents will be transferred to the 200 Area ETF or another available basin to allow access for the repair
20 activities. After the liner around the leaking or damaged section is cleaned, repairs to the geomembrane
21 will be made by as recommended by the liner vendor or others knowledgeable in liner repair. the
22 application of a piece of high density polyethylene sheeting, sufficient in size to extend approximately 8
23 to 15 centimeters beyond the damaged area, or as recommended by the vendor. A round or oval patch
24 will be installed using the same type of equipment and criteria used for the initial field installations.

25 **C.5.2.4.2 Control of Air Emissions**

26 The floating covers limit evaporation of aqueous waste and releases of volatile organic compounds into
27 the atmosphere. To accommodate volumetric changes in the air between the fluid in the basin and the
28 cover, and to avoid problems related to 'sealing' the basins too tightly, each basin is equipped with a
29 carbon filter breather vent system. Any air escaping from the basins must pass through this vent,
30 consisting of a pipe that penetrates the anchor wall and extends into a carbon adsorption filter unit.

31 **C.5.2.5 Liner Coverage**

32 The liner system covers the entire ground surface that underlies the retention basins. The primary liner
33 extends up the side slopes to a concrete anchor wall at the top of the dike encircling the entire basin
34 (Figure C.16).

35 **C.5.3 Prevention of Overtopping**

36 Overtopping prevention is accomplished through administrative controls and liquid-level instrumentation
37 installed in each basin. The instrumentation includes local liquid-level indication as well as remote
38 indication at the ETF. Before an aqueous waste is transferred into a basin, administrative controls are
39 implemented to ensure overtopping will not occur during the transfer. The volume of feed to be
40 transferred is compared to the available volume in the receiving basin. The transfer is not initiated unless
41 there is sufficient volume available in the receiving basin or a cut-off level is established. The transfer
42 into the basin would be stopped when this cut-off level is reached.

43 In the event of a 25-year, 24-hour storm event, precipitation would accumulate on the basin covers.
44 Through the self-tensioning design of the basin covers and maintenance of adequate freeboard, all
45 accumulated precipitation would be contained on the covers and none would flow over the dikes or
46 anchor walls. The 25-year, 24-hour storm is expected to deliver 5.3 centimeters of rain or approximately
47 61 centimeters of snow. Cover specifications include the requirement that the covers be able to withstand

1 the load from this amount of precipitation. Because the cover floats on the surface of the fluid in the
2 basin, the fluid itself provides the primary support for the weight of the accumulated precipitation.
3 Through the cover self-tensioning mechanism, there is ample 'give' to accommodate the overlying load
4 without overstressing the anchor and attachment points.

5 Rainwater and snow evaporate readily from the cover, particularly in the arid Hanford Facility climate,
6 where evaporation rates exceed precipitation rates for most months of the year. The black color of the
7 cover further enhances evaporation. Thus, the floating cover prevents the intrusion of precipitation into
8 the basin and provides for evaporation of accumulated rain or snow.

9 **C.5.3.1 Freeboard**

10 Under current operating conditions, 0.61 meter of freeboard is maintained at each LERF basin, which
11 corresponds to an operating level of 6.8 meters, or 29.5 million liters.

12 **C.5.3.2 Immediate Flow Shutoff**

13 The mechanism for transferring aqueous waste is either through pump transfers with on/off switches or
14 through gravity transfers with isolation valves. These methods provide positive ability to shut off
15 transfers immediately in the event of overtopping. Overtopping a basin during a transfer is very unlikely
16 because the low flow rate into the basin provides long response times. At a flow rate of 284 liters per
17 minute, approximately 11 days would be required to fill a LERF basin from the 6.8-meter operating level
18 (i.e., 0.61 meter of freeboard) to maximum capacity of 34 million liters (i.e., the 7.4-meter level).

19 **C.5.3.3 Outflow Destination**

20 Aqueous waste in the LERF is transferred routinely to 200 Area ETF for treatment. However, should it
21 be necessary to immediately empty a basin, the aqueous waste either would be transferred to the 200 Area
22 ETF for treatment or transferred to another basin (or basins), whichever is faster. If necessary a
23 temporary pumping system may be installed to increase the transfer rate.

24 **C.5.4 Structural Integrity of Dikes**

25 The structural integrity of the dikes was certified attesting to the structural integrity of the dikes, signed
26 by a qualified, registered professional engineer.

27 **C.5.4.1 Dike Design, Construction, and Maintenance**

28 The dikes of the LERF are constructed of onsite native soils, generally consisting of cobbles and gravels.
29 Well-graded mixtures were specified, with cobbles up to 15 centimeters in the largest dimension, but not
30 constituting more than 20 percent of the volume of the fill. The dikes are designed with a 3:1 (3 units
31 horizontal to 1 unit vertical) slope on the basin side, and 2.25:1 on the exterior side. The dikes are
32 approximately 8.2 meters high from the bottom of the basin, and 3 meters above grade.

33 Calculations were performed to verify the structural integrity of the dikes (HNF 1997). The calculations
34 demonstrate that the structural strength of the dikes is such that, without dependence on any lining
35 system, the sides of the basins can withstand the pressure exerted by the maximum allowable quantity of
36 fluid in the impoundment. The dikes have a factor of safety greater than 2.5 against failure by sliding.

37 **C.5.4.2 Dike Stability and Protection**

38 In the following paragraphs, various aspects of stability for the LERF dikes and the concrete anchor wall
39 are presented, including slope failure, hydrostatic pressure, and protection from the environment.

40 **Failure in Dike/Impoundment Cut Slopes.** A slope stability analysis was performed to determine the
41 factor of safety against slope failure. The computer program 'PCSTABL5' from Purdue University, using
42 the modified Janbu Method, was employed to evaluate slope stability under both static and seismic
43 loading cases. One hundred surfaces per run were generated and analyzed. The assumptions used were
44 as follows (Chen-Northern 1991b):

- 45 • Weight of gravel: 2,160 kilograms per cubic meter

- 1 • Maximum dry density of gravel: 2,315 kilograms per cubic meter
- 2 • Mohr-Coulomb shear strength angle for gravel: minimum 33 degrees
- 3 • Weight of soil/bentonite: 1,600 kilograms per cubic meter
- 4 • Mohr-Coulomb shear strength angle for soil/bentonite: minimum 30 degrees
- 5 • Slope: 3 horizontal: 1 vertical
- 6 • No fluid in impoundment (worst case for stability)
- 7 • Soils at in-place moisture (not saturated conditions)

8 Results of the static stability analysis showed that the dike slopes were stable with a minimum factor of
9 safety of 1.77 (Chen-Northern 1991b).

10 The standard horizontal acceleration required in the *Hanford Plant Standards*, "Standard Architectural-
11 Civil Design Criteria, Design Loads for Facilities" (DOE-RL 1988), for structures on the Hanford Site is
12 0.12 g. Adequate factors of safety for cut slopes in units of this type generally are considered 1.5 for
13 static conditions and 1.1 for dynamic stability (Golder 1989). Results of the stability analysis showed that
14 the LERF basin slopes were stable under horizontal accelerations of 0.10 and 0.15 g, with minimum
15 factors of safety of 1.32 and 1.17, respectively (Chen-Northern 1991b). Printouts from the PCSTABL5
16 program are provided in *Calculations for Liquid Effluent Retention Facility Part B Permit Application*
17 (HNF 1997).

18 **Hydrostatic Pressure.** Failure of the dikes due to buildup of hydrostatic pressure, caused by failure of
19 the leachate system or liners, is very unlikely. The liner system is constructed with two essentially
20 impermeable layers consisting of a synthetic layer overlying a soil layer with low-hydraulic conductivity.
21 It would require a catastrophic failure of both liners to cause hydrostatic pressures that could endanger
22 dike integrity. Routine inspections of the leachate detection system, indicating quantities of leachate
23 removed from the basins, provide an early warning of leakage or operational problems that could lead to
24 excessive hydrostatic pressure. A significant precipitation event (e.g., a 25-year, 24-hour storm) will not
25 create a hydrostatic problem because the interior sidewalls of the basins are covered completely by the
26 liners. The covers can accommodate this volume of precipitation without overtopping the dike
27 (Section C.5.3), and the coarse nature of the dike and foundation materials on the exterior walls provides
28 for rapid drainage of precipitation away from the basins.

29 **Protection from Root Systems.** Risk to structural integrity of the dikes because of penetrating root
30 systems is minimal. Excavation and construction removed all vegetation on and around the
31 impoundments, and native plants (such as sagebrush) grow very slowly. The large grain size of the
32 cobbles and gravel used as dike construction material do not provide an advantageous germination
33 medium for native plants. Should plants with extending roots become apparent on the dike walls, the
34 plants will be controlled with appropriate herbicide application.

35 **Protection from Burrowing Mammals.** The cobble size materials that make up the dike construction
36 material and the exposed nature of the dike sidewalls do not offer an advantageous habitat for burrowing
37 mammals. Lack of vegetation on the LERF site discourages foraging. The risk to structural integrity of
38 the dikes from burrowing mammals is therefore minimal. Periodic visual inspections of the dikes provide
39 observations of any animals present. Should burrowing mammals be noted onsite, appropriate pest
40 control methods such as trapping or application of rodenticides will be employed.

41 **Protective Cover.** Approximately 7.6 centimeters of crushed gravel serve as the cover of the exterior
42 dike walls. This coarse material is inherently resistant to the effect of wind because of its large grain size.
43 Total annual precipitation is low (16 centimeters) and a significant storm event (e.g., a 25-year, 24-hour
44 storm) could result in about 5.3 centimeters of precipitation in a 24-hour period. The absorbent capacity
45 of the soil exceeds this precipitation rate; therefore, the impact of wind and precipitation run-on to the
46 exterior dike walls will be minimal.

1 **C.5.5 Piping Systems**

2 Aqueous waste from the 242-A Evaporator is transferred to the LERF using a pump located in the
3 242-A Evaporator and approximately 1,500 meters of pipe, consisting of a 3-inch carrier pipe within a
4 6-inch outer containment pipeline. Flow through the pump is controlled through a valve at flow rates
5 from 150 to 300 liters per minute. The pipeline exits the 242-A Evaporator below grade and remains
6 below grade at a minimum 1.2 meter depth for freeze protection, until the pipeline emerges at the LERF
7 catch basin, at the corner of each basin. All piping at the catch basin that is less than 1.2 meters below
8 grade is wrapped with electric heat tracing tape and insulated for protection from freezing.

9 The transfer line from the 242-A Evaporator is centrifugally cast, fiberglass-reinforced epoxy thermoset
10 resin pressure pipe fabricated to meet the requirements of ASME D2997 (ASME 1984). The 3-inch
11 carrier piping is centered and supported within 6-inch containment piping. Pipe supports are fabricated of
12 the same material as the pipe, and meet the strength requirements of ANSI B31.3 (ANSI 1987) for dead
13 weight, thermal, and seismic loads. A catch basin is provided at the northwest corner of each basin where
14 piping extends from the basin to allow for basin-to-basin and basin-to-200 Area ETF liquid transfers.
15 Drawing H-2-88766, Sheets 1 through 4, provide schematic diagrams of the piping system at LERF.
16 Drawing H-2-79604 provides details of the piping from the 242-A Evaporator to LERF.

17 **C.5.5.1 Secondary Containment System for Piping**

18 The 6-inch containment piping encases the 3-inch carrier pipe from the 242-A Evaporator to the LERF.
19 All of the piping and fittings that are not directly over a catch basin or a basin liner are of this pipe-
20 within-a-pipe construction. A catch basin is provided at the northwest corner of each basin where the
21 inlet pipes, leachate risers, and transfer pipe risers emerge from the basin. The catch basin consists of a
22 20-centimeter-thick concrete pad at the top of the dike. The perimeter of the catch basin has a
23 20-centimeter-high curb, and the concrete is coated with a chemical resistant epoxy sealant. The concrete
24 pad is sloped so that any leaks or spills from the piping or pipe connections will drain into the basin. The
25 catch basin provides an access point for inspecting, servicing, and operating various systems such as
26 transfer valving, leachate level instrumentation and leachate pump. Drawing H-2-79593 provides a
27 schematic diagram of the catch basins.

28 **C.5.5.2 Leak Detection System**

29 During operation, the 242-A Evaporator receives dilute tank waste directly from the Tank Farms, treats
30 waste by evaporation, and returns the concentrated waste to Tank Farms. The process condensate which
31 is generated is transferred to LERF. Single-point electronic leak detection elements are installed along
32 the transfer line at 305-meter intervals. The leak detection elements are located in the bottom of specially
33 designed test risers. Each sensor element employs a conductivity sensor, which is connected to a cable
34 leading back to the 242-A Evaporator control room. If a leak develops in the carrier pipe, fluid will travel
35 down the exterior surface of the carrier pipe or the interior of the containment pipe. As moisture contacts
36 a sensor unit, an alarm sounds in the ETF control room, which is monitored continuously when the 242-A
37 evaporator is transferring liquids to LERF. If the alarm sounds, ETF Operations staff troubleshoots the
38 alarm and, upon verification of a leak, requests that the pump located in the 242-A Evaporator be shut
39 down to stop the flow of process condensate through the transfer line. The 242-A Evaporator has limited
40 surge capacity, and its operation is closely tied to supporting Tank Farm operations. The flow of process
41 condensate to LERF is not stopped automatically by indication of a possible leak in the primary transfer
42 line. A low-volume air purge of the annulus between the carrier pipe and the containment pipe is
43 provided to prevent condensation buildup and minimize false alarms by the leak detection elements.

44 The catch basins have conductivity leak detectors that alarm in the ETF control room. Leak detector
45 alarms are monitored in the control room continuously during aqueous waste transfers and at least daily
46 when no transfers are occurring. Leaks into the catch basins drain back to the basin through a 5.1-
47 centimeter drain on the floor of the catch basin.

1 **C.5.5.3 Certification**

2 Although an integrity assessment is not required for piping associated with surface impoundments, an
3 assessment of the transfer liner was performed, including a hydrostatic leak/pressure test at
4 10.5 kilograms per square centimeter gauge. A statement by an independent, qualified, registered
5 professional engineer attesting to the integrity of the piping system is included in *Integrity Assessment*
6 *Report for the 242-A Evaporator/LERF Waste Transfer Piping, Project W105* (WHC 1993), along with
7 the results of the leak/pressure test.

8 **C.5.6 Double Liner and Leak Detection, Collection, and Removal System**

9 The double-liner system for LERF is discussed in Section C.5.2. The leachate detection, collection, and
10 removal system (Figure C.18 and Figure C.19) was designed and constructed to remove leachate that
11 might permeate the primary liner. System components for each basin include:

- 12 • 30.5-centimeter layer of drainage gravel below the primary liner at the bottom of the basin
- 13 • Geonet below the primary liner on the sidewalls to direct leachate to the gravel layer
- 14 • 3.0-meter by 1.8-meter by 0.30-meter-deep leachate collection sump consisting of a 25 millimeter
15 high-density polyethylene flat stock, geotextile to trap large particles in the leachate, and
16 1.5-millimeter high-density polyethylene rub sheet set on the secondary liner
- 17 • 10-inch and 4-inch perforated leachate high-density polyethylene riser pipes from the leachate
18 collection sump to the catch basin northwest of the basin
- 19 • Leachate collection sump level instrumentation installed in the 4-inch riser
- 20 • Level sensors, submersible leachate pump, and 1.5-inch fiberglass-reinforced epoxy thermoset resin
21 pressure piping installed in the 10-inch riser
- 22 • Piping at the catch basin to route the leachate through 1.5-inch high-density polyethylene pipe back to
23 the basins

24 The bottom of the basins has a two percent slope to allow gravity flow of leachate to the leachate
25 collection sump. This exceeds the minimum of 1 percent slope required by [WAC 173-303-650\(j\)](#) for new
26 surface impoundments. Material specifications for the leachate collection system are given in
27 Section C.5.2.1.1.

28 Calculations demonstrate that fluid from a small hole (2 millimeter) (EPA 1989, p. 122) at the furthest
29 end of the basin, under a low head situation, would travel to the sump in less than 24 hours (HNF 1997).
30 Additional calculations indicate the capacity of the pump to remove leachate is sufficient to allow time to
31 readily identify a leak and activate emergency procedures (HNF 1997).

1 The fluid level in each leachate sump is required to be maintained below 33 centimeters to prevent
2 significant liquid backup into the drainage layer. The leachate pump is activated when the liquid level in
3 the sump reaches about 28 centimeters, and is shut off when the sump liquid level reaches about
4 18 centimeters. This operation may be done either manually or automatically. Liquid level control is
5 accomplished with conductivity probes that trigger relays selected specifically for application to
6 submersible pumps and leachate fluids. A flow meter/totalizer on the leachate return pipe measures fluid
7 volumes pumped and pumping rate from the leachate collection sumps, and indicates volume and flow
8 rate on local readouts. In addition, a timer on the leachate pump tracks the cumulative pump operating
9 time. Other instrumentation provided is real-time continuous level monitoring with readout at the catch
10 basin. Leachate levels are monitored at least weekly. A sampling port is provided in the leachate piping
11 system at the catch basin. The leak rate through the primary liner can be calculated using two methods: 1)
12 measured as the leachate flow meter/totalizer readings (flow meters/totalizers are located on the outflow
13 line from the collection sumps in the bottom of the LERF basins), and 2) calculated using the pump
14 operating time readings multiplied by the pump flow rate (the pump runs at a constant flow rate).
15 Calculations using either method are sufficient for compliance. For more information on inspections,
16 refer to Addendum I.

17 The stainless steel leachate pump delivers 5 gallons per minute (19 liters per minute). The leachate pump
18 returns draw liquid from the sump via 1.5-inch pipe and discharges into the basin through 1.5-inch high-
19 density polyethylene pipe.

20 **C.5.7 Construction Quality Assurance**

21 The construction quality assurance plan and complete report of construction quality assurance inspection
22 and testing results are provided in *242-A Evaporator Interim Retention Basin Construction Quality*
23 *Assurance Plan* (KEH 1991). A general description of construction quality assurance procedures is
24 outlined in the following paragraphs.

25 For excavation of the basins and construction of the dikes, regular inspections were conducted to ensure
26 compliance with procedures and drawings, and compaction tests were performed on the dike soils.

27 For the soil/bentonite layer, test fills were first conducted in accordance with EPA guidance to
28 demonstrate compaction procedures and to confirm compaction and permeability requirements can be
29 met. The ratio of bentonite to soil and moisture content was monitored; lifts did not exceed
30 15 centimeters before compaction, and specific compaction procedures were followed. Laboratory and
31 field tests of soil properties were performed for each lift and for the completed test fill. The same suite of
32 tests was conducted for each lift during the laying of the soil/bentonite admixture in the basins.

33 Geotextiles and geomembranes were laid in accordance with detailed procedures and quality assurance
34 programs provided by the manufacturers and installers. These included destructive and nondestructive
35 tests on the geomembrane seams, and documentation of field test results and repairs.

36 **C.5.8 Proposed Action Leakage Rate and Response Action Plan**

37 An action leakage rate limit is established where action must be taken due to excessive leakage from the
38 primary liner. The action leak rate is based on the maximum design flow rate the leak detection system
39 can remove without the fluid head on the bottom liner exceeding 30 centimeters. The limiting factor in
40 the leachate removal rate is the hydraulic conductivity of the drainage gravel. An action leakage rate
41 (also called the rapid or large leak rate) of 20,000 liters per hectare per day (2,100 gallons/acre/day) was
42 calculated for each basin (WHC 1992b).

43 When it is determined that the action leakage rate has been exceeded, the response action plan will follow
44 the actions in [WAC 173-303-650\(11\)\(b\)](#) and (c), which includes notification of Ecology in writing
45 within 7 days, assessing possible causes of the leak, and determining whether waste receipt should be
46 curtailed and/or the basin emptied.

1 **C.5.9 Dike Structural Integrity Engineering Certification**

2 The structural integrity of the dikes was certified attesting to the structural integrity of the dikes, signed
3 by a qualified, registered professional engineer.

4 **C.5.10 Management of Ignitable, Reactive, or Incompatible Wastes**

5 Although ignitable or reactive aqueous waste might be received in small quantities at LERF, such
6 aqueous waste is mixed with dilute solutions in the basins, removing the ignitable or reactive
7 characteristics. For compatibility requirements with the LERF liner, refer to Addendum B, Waste
8 Analysis Plan.

9 **C.6 AIR EMISSIONS CONTROL**

10 This section addresses the 200 Area ETF requirements of Air Emission Standards for Process Vents,
11 under [40 CFR 264](#), Subpart AA ([WAC 173-303-690](#) incorporated by reference) and Subpart CC. The
12 requirements of [40 CFR 264](#), Subpart BB ([WAC 173-303-691](#)) is not applicable because aqueous waste
13 with 10 percent or greater organic concentration would not be acceptable for processing at the ETF.

14 **C.6.1 Applicability of Subpart AA Standards**

15 The 200 Area ETF evaporator and thin film dryer perform operations that specifically require evaluation
16 for applicability of [WAC 173-303-690](#). Aqueous waste in these units routinely contains greater than 10
17 parts per million concentrations of organic compounds and are, therefore, subject to air emission
18 requirements under [WAC 173-303-690](#). Organic emissions from all affected process vents on the
19 Hanford Facility must be less than 1.4 kilograms per hour and 2.8 mega grams per year, or control
20 devices must be installed to reduce organic emissions by 95 percent.

21 The vessel off gas system provides a process vent system. This system provides a slight vacuum on the
22 200 Area ETF process vessels and tanks (refer to Section C.2.5.2). Two vessel vent header pipes
23 combine and enter the vessel off gas system filter unit consisting of a demister, electric heater, prefilter,
24 high-efficiency particulate air filters, activated carbon absorber, and two exhaust fans (one fan in service
25 while the other is backup). The vessel off gas system filter unit is located in the high-efficiency
26 particulate air filter room west of the process area. The vessel off gas system exhaust discharges into the
27 larger building ventilation system, with the exhaust fans and stack located outside and immediately west
28 of the ETF. The exhaust stack discharge point is 15.5 meters above ground level.

29 The annual average flow rate for the 200 Area ETF stack (which is the combined vessel off gas and
30 building exhaust flow rates) is 1600 cubic meters per minute with a total annual flow of approximately
31 8.4 E+08 cubic meters. During waste processing, the airflow through just the vessel off gas system is
32 about 23 standard cubic meters per minute.

33 Organic emissions occur during waste processing, which occurs less than 310 days each year
34 (i.e., 85 percent operating efficiency). This operating efficiency represents the maximum annual
35 operating time for the ETF, as shutdowns are required during the year for planned maintenance outages
36 and for reconfiguring the 200 Area ETF to accommodate different aqueous waste.

37 **C.6.2 Process Vents - Demonstrating Compliance**

38 This section outlines how the 200 Area ETF complies with the requirements and includes a discussion of
39 the basis for meeting the organic emissions limits, calculations demonstrating compliance, and conditions
40 for reevaluation.

41 **C.6.2.1 Basis for Meeting Limits/Reductions**

42 The 242-A Evaporator and the 200 Area ETF are currently the only operating TSD units that contribute to
43 the Hanford Facility volatile organic emissions under [40 CFR 264](#), Subpart AA. The combined release
44 rate is currently well below the threshold of 1.4 kilograms per hour or 2,800 kilograms per year of volatile
45 organic compounds. As a result, the 200 Area ETF meets these standards without the use of air pollution
46 control devices.

1 The amount of organic emissions could change as waste streams are changed, or TSD units are brought
2 online or are deactivated. The organic air emissions summation will be re-evaluated periodically as
3 condition warrants. Operations of the TSD units operating under [40 CFR 264](#), Subpart AA, will be
4 controlled to maintain Hanford Facility emissions below the threshold limits or pollution control device(s)
5 will be added, as necessary, to achieve the reduction standards specified under [40 CFR 264](#), Subpart AA.

6 **C.6.2.2 Demonstrating Compliance**

7 Calculations to determine organic emissions are performed using the following assumptions:

- 8 • Maximum flow rate from LERF to 200 Area ETF is 568 liters per minute.
- 9 • Emissions of organics from tanks and vessels upstream of the UV/OX process are determined from
10 flow and transfer rates given in *Clean Air Act Requirements, WAC 173-400, As-built Documentation,*
11 *Project C-018H, 242-A Evaporator/PUREX Plant Process Condensate Treatment Facility*
12 *(Adtechs 1995).*
- 13 • UV/OX reaction rate constants and residence times are used to determine the amount of organics,
14 which are destroyed in the UV/OX process. These constants are given in *200 Area Effluent*
15 *Treatment Facility Delisting Petition (DOE/RL 1992).*
- 16 • All organic compounds that are not destroyed in the UV/OX process are assumed to be emitted from
17 the tanks and vessels into the vessel off gas system.
- 18 • No credit for removal of organic compounds in the vessel off gas system carbon absorber unit is
19 taken. The activated carbon absorbers are used if required to reduce organic emissions.

20 The calculation to determine organic emissions consists of the following steps:

- 21 1. Determine the quantity of organics emitted from the tanks or vessels upstream of the UV/OX process,
22 using transfer rate values
- 23 2. Determine the concentration of organics in the waste after the UV/OX process using UV/OX reaction
24 rates and residence times. If the 200 Area ETF is configured such that the UV/OX process is not
25 used, a residence time of zero is used in the calculations (i.e., none of the organics are destroyed)
- 26 3. Assuming all the remaining organics are emitted, determine the rate which the organics are emitted
27 using the feed flow rate and the concentrations of organics after the UV/OX process
- 28 4. The amount of organics emitted from the vessel off gas system is the sum of the amount
29 calculated in steps 1 and 3.

30 The organic emission rates and quantity of organics emitted during processing are determined using these
31 calculations and are included in the Hanford Facility Operating Record, LERF and 200 Area ETF file.

32 **C.6.2.3 Reevaluating Compliance with Subpart AA Standards**

33 Calculations to determine compliance with Subpart AA will be reviewed when any of the following
34 conditions occur at the 200 Area ETF:

- 35 • Changes in the maximum feed rate to the 200 Area ETF (i.e., greater than the 568 liters per minute
36 flow rate)
- 37 • Changes in the configuration or operation of the 200 Area ETF that would modify the assumptions
38 given in Section C.6.2.2 (e.g., taking credit for the carbon absorbers as a control device)
- 39 • Annual operating time exceeds 310 days.

40 **C.6.3 Applicability of Subpart CC Standards**

41 The air emission standards of [40 CFR 264](#), Subpart CC apply to tank, surface impoundment, and
42 container storage units that manage wastes with average volatile organic concentrations equal to or
43 exceeding 500 parts per million by weight, based on the hazardous waste composition at the point of

1 origination (61 FR 59972). However, TSD units that are used solely for management of mixed waste are
2 exempt. Mixed waste is managed at the LERF and 200 Area ETF and dangerous waste could be treated
3 and stored at these TSD units.

4 TSD owner/operators are not required to determine the concentration of volatile organic compounds in a
5 hazardous waste if the wastes are placed in waste management units that employ air emission controls
6 that comply with the Subpart CC standards. Therefore, the approach to Subpart CC compliance at the
7 LERF and 200 Area ETF is to demonstrate that the LERF and 200 Area ETF meet the Subpart CC control
8 standards ([40 CFR 264.1084](#) – [40 CFR 264.1086](#)).

9 **C.6.3.1 Demonstrating Compliance with Subpart CC for Tanks**

10 Since the 200 Area ETF tanks already have process vents regulated under [40 CFR 264](#), Subpart AA
11 ([WAC 173-303-690](#)), they are exempt from Subpart CC [[40 CFR 264.1080\(b\)\(8\)](#)].

12 **C.6.3.2 Demonstrating Compliance with Subpart CC for Containers**

13 Container Level 1 and Level 2 standards are met at the 200 Area ETF by managing all dangerous and/or
14 mixed wastes in U.S. Department of Transportation containers [[40 CFR 264.1086\(f\)](#)]. Level 1 containers
15 are those that store more than 0.1 cubic meters and less than or equal to 0.46 cubic meters. Level 2
16 containers are used to store more than 0.46 cubic meters of waste, which are in 'light material service'.
17 Light material service is defined where a waste in the container has one or more organic constituents
18 with a vapor pressure greater than 0.3 kilopascals at 20 C, and the total concentration of such
19 constituents is greater than or equal to 20 percent by weight.

20 The monitoring requirements for Level 1 and Level 2 containers include a visual inspection when the
21 container is received at the 200 Area ETF and when the waste is initially placed in the container.
22 Additionally, at least once every 12 months when stored onsite for 1 year or more, these containers must
23 be inspected.

24 If compliant containers are not used at the 200 Area ETF, alternate container management practices are
25 used that comply with the Level 1 standards. Specifically, the Level 1 standards allow for a "container
26 equipped with a cover and closure devices that form a continuous barrier over the container openings such
27 that when the cover and closure devices are secured in the closed position there are no visible holes, gaps,
28 or other open spaces into the interior of the container. The cover may be a separate cover installed on the
29 container...or may be an integral part of the container structural design..." [[40 CFR 264.1086\(c\)\(1\)\(ii\)](#)].
30 An organic-vapor-suppressing barrier, such as foam, may also be used [[40 CFR 264.1086\(c\)\(1\)\(iii\)](#)].
31 Section C.3 provides detail on container management practices at the 200 Area ETF.

32 Container Level 3 standards apply when a container is used for the "treatment of a hazardous waste by a
33 waste stabilization process" [[40 CFR 264.1086\(2\)](#)]. Because treatment in containers using the
34 stabilization process is not provided at the 200 Area ETF, these standards do not apply.

35 **C.6.3.3 Demonstrating Compliance with Subpart CC for Surface Impoundments**

36 The Subpart CC emission standards are met at LERF using a floating membrane cover that is constructed
37 of very-low-density polyethylene that forms a continuous barrier over the entire surface area
38 [[40 CFR 264.1085\(c\)](#)]. This membrane has both organic permeability properties equivalent to a high-
39 density polyethylene cover and chemical/physical properties that maintain the material integrity for the
40 intended service life of the material. The additional requirements for the floating cover at the LERF have
41 been met (Section C.5.2.4).

42 **C.7 ENGINEERING DRAWINGS**

43 **C.7.1 Liquid Effluent Retention Facility**

44 Drawings of the containment systems at the LERF are summarized in Table C.1. Because the failure of
45 these containment systems at LERF could lead to the release of dangerous waste into the environment,

1 modifications that affect these containment systems will be submitted to the Washington State
2 Department of Ecology, as a Class 1, 2, or 3 Permit modification, as required by [WAC 173-303-830](#).

3 **Table C.1. Liquid Effluent Retention Facility Containment System**

LERF System	Drawing Number	Drawing Title
Bottom Liner	H-2-79590, Sheet 1	Civil Plan, Sections and Details; Cell Basin Bottom Liner
Top Liner	H-2-79591, Sheet 1	Civil Plan, Sections and Details; Cell Basin Bottom Liner
Catch Basin	H-2-79593, Sheet 1, 3-5	Civil Plan, Section and Details; Catch Basin

4 The drawings identified in Table C.2 illustrate the piping and instrumentation configuration within LERF,
5 and of the transfer piping systems between the LERF and the 242-A Evaporator. These drawings are
6 provided for general information and to demonstrate the adequacy of the design of the LERF as a surface
7 impoundment.

8 **Table C.2. Liquid Effluent Retention Facility Piping and Instrumentation**

LERF System	Drawing Number	Drawing Title
Transfer Piping to 242-A Evaporator	H-2-79604, Sheet 1	Piping Plot and Key Plans; 242-A Evaporator Condensate Stream
LERF Piping and Instrumentation	H-2-88766, Sheet 1	P&ID; LERF Basin and ETF Influent
	H-2-88766, Sheet 2	P&ID; LERF Basin and ETF Influent
	H-2-88766, Sheet 3	P&ID; LERF Basin and ETF Influent
	H-2-88766, Sheet 4	P&ID; LERF Basin and ETF Influent
Legend	H-2-89351, Sheet 1	Piping & Instrumentation Diagram - Legend

9 **C.7.2 200 Area Effluent Treatment Facility**

10 Drawings of the secondary containment systems for the 200 Area ETF containers, and tanks and process
11 units, and for the Load-In Tanks are summarized in Table C.3. Because the failure of the secondary
12 containment systems could lead to the release of dangerous waste into the environment, modifications,
13 which affect the secondary containment systems, will be submitted to the Washington State Department
14 of Ecology, as a Class 1, 2, or 3 Permit modification, as required by [WAC 173-303-830](#).

15 **Table C.3. Effluent Treatment Facility and Load-In Station Secondary Containment**
16 **Systems**

200 Area ETF Process Unit	Drawing Number	Drawing Title
Surge Tank, Process/ Container Storage Areas and Trenches - Foundation and Containment	H-2-89063, Sheet 1	Architectural/structural – Foundation and Grade Beam Plan
Sump Tank Containment	H-2-89065, Sheet 1	Architectural/structural – Foundation, Sections and Detail
Verification Tank Foundation and Containment	H-2-89068, Sheet 1	Architectural/structural – Verification Tank Foundation
Load-In Facility Foundation and Containment	H-2-817970, Sheet 1	Structural – ETF Truck Load-in Facility Plans and Sections
Load-In Facility Foundation and Containment	H-2-817970, Sheet 2	Structural – ETF Truck Load-in Facility Sections and Details

17 The drawings identified in Table C.4 provide an illustration of the piping and instrumentation
18 configuration for the major process units and tanks at the ETF, and the Load-In Tanks. Drawings of the
19 transfer piping systems between the LERF and 200 Area ETF, and between the Load-In Station and the

1 200 Area ETF also are presented in this table. These drawings are provided for general information and
 2 to demonstrate the adequacy of the design of the tank systems.

3

4 **Table C.4. Major Process Units and Tanks at the Effluent Treatment Facility and Load-In**
 5 **Station**

200 Area ETF Process Unit	Drawing Number	Drawing Title
Load-In Facility	H-2-817974, Sheet 1	P&ID – ETF Truck Load-In Facility
Load-In Facility	H-2-817974, Sheet 2	P&ID – ETF Truck Load-In Facility
Surge Tank	H-2-89337, Sheet 1	P&ID – Surge Tank System
UV/Oxidation	H-2-88976, Sheet 1	P&ID – UV Oxidizer Part 1
UV/Oxidation	H-2-89342, Sheet 1	P&ID – UV Oxidizer Part 2
Reverse Osmosis	H-2-88980, Sheet 1	P&ID – 1st RO Stage
Reverse Osmosis	H-2-88982, Sheet 1	P&ID – 2nd RO Stage
IX/Polishers	H-2-88983, Sheet 1	P&ID – Polisher
Verification Tanks	H-2-88985, Sheet 1	P&ID – Verification Tank System
ETF Evaporator	H-2-89335, Sheet 1	P&ID – Evaporator
Thin Film Dryer	H-2-88989, Sheet 1	P&ID – Thin Film Dryer
Transfer Piping from LERF to ETF	H-2-88768, Sheet 1	Piping Plan/Profile 4" – 60M-002-M17 and 3" – 60M-001-M17
Transfer Piping from Load-In Facility to ETF	H-2-817969, Sheet 1	Civil – ETF Truck Load-In Facility Site Plan

6

1 **Table C.5. 200 Area Effluent Treatment Facility Tank Systems Information**

Tank Description	Material of Construction	Maximum Tank Capacity ¹ liters	Inner diameter meters	Height meters	Shell Thickness ² centimeters	Corrosion Protection ³
Load-in tanks 59A-TK-109/-117 (2)	304 SS	34,350	3.6	4.7	0.64	Type 304 SS
Load-in tank 59A-TK-1	FRP	26,000	3.0	3.8	0.48 (dome) 0.63 (walls & bottom)	FRP
Surge tank	304 SS	462,000	7.9	9.2	0.48	Type 304 SS
pH adjustment tank	304 SS	16,700	3.0	2.5	0.64	Type 304 SS
First RO feed tank	304 SS	20,600	3.0	3.2	0.64	Type 304 SS
Second RO feed tank	304 SS	9,000	Nonround tank 3.0 m x 1.5 m	1.5	0.48 w/rib stiffeners	Type 304 SS
Effluent pH adjustment tank	304 SS	14,400	2.4	3.6	0.64	Type 304 SS
Verification tanks (3)	Carbon steel with epoxy lining	3,000,000	18.3	11.4	0.79	epoxy coating
Secondary waste receiving tanks (2)	304 SS	73,800	4.3	5.7	0.64	Type 304 SS
Concentrate tanks (2)	316L SS	24,900	3.0	3.8	0.64	Type 316 SS
ETF evaporator (Vapor Body)	Alloy 625	20,000	2.4	6.8	variable	Alloy 625
Distillate flash tank	304 SS	950	Horizontal tank 0.76	Length 2.2	0.7	304 SS
Sump tank 1	304 SS	6,900	1.5 x 1.5	3.4	0.48	304 SS
Sump tank 2	304 SS	6,700	1.5 x 1.5	3.4	0.48	304 SS

- 2 ¹The maximum operating volume of the tanks is identified.
3 ²The nominal thickness of ETF tanks is represented.
4 ³Type 304 SS, 304L, 316 SS and alloy 625 provide corrosion protection.
5 304 SS = stainless steel type 304 or 304L.
6 316L SS = stainless steel type 316L
7 FRP = Fiberglass-reinforced plastic.
8

1 **Table C.6. 200 Area Effluent Treatment Facility Additional Tank System Information**

Tank Description	Liner Materials	Pressure Controls	Foundation Materials	Structural Support	Seams	Connections
Load-in tanks 59A-TK-109/-117 (2)	None	vent to atmosphere	concrete slab	SS skirt bolted to concrete	welded	flanged
Load-in tank 59A-TK-1	None	vent to atmosphere	concrete slab	bolted to concrete	none	flanged
Surge tank	None	vacuum breaker valve/vent to VOG	reinforced concrete ring plus concrete slab	structural steel on concrete base	welded	flanged
pH adjustment tank	None	vent to VOG	concrete slab	carbon steel skirt	welded	flanged
First RO feed tank	None	vent to VOG	concrete slab	carbon steel skirt	welded	flanged
Second RO feed tank	None	vent to VOG	concrete slab	carbon steel frame	welded	flanged
Effluent pH adjustment tank	None	vent to VOG	concrete slab	carbon steel skirt	welded	flanged
Verification tanks (3)	Epoxy	filtered vent to atmosphere	reinforced concrete ring plus concrete slab	structural steel on concrete base	welded	flanged
Secondary waste receiving tanks (2)	None	vent to VOG	concrete slab	carbon steel skirt	welded	flanged
Concentrate tanks (2)	None	vent to VOG	concrete slab	carbon steel skirt	welded	flanged
ETF evaporator (vapor body)	None	pressure indicator/pressure relief valve vapor vent to DFT/VOG	concrete slab	carbon steel frame	welded	flanged
Distillate flash tank	None	Pressure relief valve/vent to vent gas cooler/VOG	concrete slab	carbon steel I-beam and cradle	welded	flanged
Sump tank 1	None	vent to VOG	concrete containment	reinforced concrete containment basin	welded	flanged
Sump tank 2	None	vent to VOG	concrete containment	reinforced concrete containment basin	welded	flanged

- 2 DFT = distillate flash tank
- 3 VOG = vessel off gas system
- 4

1

Table C.7. Ancillary Equipment and Material Data

System	Ancillary Equipment	Number	Material	
Load-in tanks	Load-in/transfer pumps (2)	2025ED-P-103A/-103B	316 SS	
		2025ED-P-001A/-001B	Cast iron	
	Load-in filters (6)	59A-FL-001/-002/-003/-004/-005/-006	304 SS	
Surge tank	Surge tank pumps (3)	2025E-60A-P-1A/-1B/-1C	304 SS	
Rough filter	Rough filter	2025E-60B-FL-1	304 SS	
UV/OX	UV oxidation inlet cooler	2025E-60B-E-1	316 SS	
	UV oxidizers (4)	2025E-60D-UV-1A/-1B/-2A/-2B	316 SS	
pH adjustment	pH adjustment pumps (2)	2025E-60C-P-1A/-1B	304 SS	
Peroxide decomposer	H2O2 decomposers (2)	2025E-60D-CO-1A/-1B	CS with epoxy coating	
Fine filter	Fine filter	2025E-60B-FL-2	304 SS	
Degasification	Degasification column inlet cooler	2025E-60E-E-1	316 SS	
	Degasification column	2025E-60E-CO-1	FRP	
	Degasification pumps (2)	2025E-60E-P-1A/-1B	316 SS	
RO	Feed/booster pumps (6)	2025E-60F-P-1A/-1B/-2A/-2B/-3A/-3B	304 SS	
	Reverse osmosis arrays (21)	2025E-60F-RO-01 through -21	Membranes: polyamide Outer piping: 304 SS	
IX/Polishers	Polishers (3)	2025E-60G-IX-1A/-1B-1C	CS with epoxy coating	
	Resins strainers (3)	2025E-60G-S-1A/-1B/-1C	304 SS	
Effluent pH adjustment	Recirculation/transfer pumps (2)	2025E-60C-P-2A/-2B	304 SS/PVC	
Verification tanks	Return pump	2025E-60H-P-1	304 SS	
	Transfer pumps (2)	2025E-60H-P-2A/-2B		
Secondary waste receiving tanks	Secondary waste feed pumps (2)	2025E-60I-P-1A/-1B	304 SS	
ETF evaporator system	Feed/distillate heat exchanger	2025E-60I-E-02	Tubes: 316 SS Shell: 304 SS	
	Heater (reboiler)	2025E-60I-E-01	Tubes: alloy 625 Shell: 304 SS	
	Recirculation pump	2025E-60I-P-02	316 SS	
	Concentrate transfer pump	2025E-60I-P-04	316 SS	
	Entrainment separator	2025E-60I-DE-01	Top section: 316 SS Bottom section: alloy 625	
	Vapor compressor (incl. silencers)	2025E-60I-C-01	304 SS	
	Silencer drain pump	2025E-60I-P-06	316 SS	
	Level control tank	2025E-60I-TK-5	304 SS	
	Distillate flash tank pump	2025E-60I-P-03	316 SS	
	Concentrate tanks	Concentrate circulation pumps (2)	2025E-60J-P-1A/-1B	316 SS
	Thin film dryer	Concentrate feed pump	2025E-60J-P-2	316 SS
		Thin film dryer	2025E-60J-D-1	Interior surfaces: alloy 625 Rotor and blades: 316 SS
Powder hopper		2025E-60J-H-1	316 SS	
Spray condenser		2025E-60J-DE-01	316 SS	
Distillate condenser		2025E-60J-CND-01	Tubes: 304 SS Shell: CS	
Dryer distillate pump		2025E-60J-P-3	316 SS	
Resin dewatering		Dewatering pump	2025E-80E-P-1	

Table C.8. Concrete and Masonry Coatings

Location	Product Name	Applied Film Thickness, Estimated
ETF Process and Container Storage Areas		
Floor: Topcoat	Steelcote Floor-Nu Finish ¹	2 coats at 10-12 mils
Floor: Primer	Steelcote Monomid Hi-Build ¹	2.0 mils
Walls to 7 feet, Doors & Jambs	Chemproof PermaCoat 4000 Vertical ²	2 coats at 12-16 mils
Load-in Station Tank Pit		
Floor and Walls	Ameron Amercoat 351 ³	2 coats at 8.0-12 mils
Surge Tank and Verification Tank Berms		
Floors (and Walls at Surge Tank): Topcoat	KCC Corrosion Control Elasti-Liner I ⁴	80 mils
Floors (and Walls at Surge Tank): Primer	KCC Corrosion Control Techni-Plus E3 ⁴	5.0-7.0 mils

¹Floor-Nu Finish and Monomid Hi-Build are trademarks of Steelcote Manufacturing, Incorporated

²PermaCoat is a trademark of Chemproof Polymers, Incorporated

³Amercoat is a trademark of Ameron International, Incorporated

⁴Elasti-Liner and Techni-Plus are trademarks of KCC Corrosion Control, Incorporated

Table C.9. Geomembrane Material Specifications

Property	Value
Specific gravity	0.932 to 0.950
Melt flow index	1.0 g/10 min., maximum
Thickness (thickness of flow marks shall not exceed 200% of the nominal liner thickness)	60 mil 310% (1.5 mm 3 10%)
Carbon black content	1.8 to 3%, bottom liner 2 to 3% top liner
Tensile properties (each direction)	
Tensile strength at yield	21.5 kgf/cm width, minimum
Tensile strength at break	32.2 kgf/cm width, minimum
Elongation at yield	10%, minimum
Elongation at break	500%, minimum
Tear resistance	13.6 kgf, minimum
Puncture resistance	31.3 kgf, minimum
Low temperature/brittleness	-400 C, maximum
Dimensional (%change each direction)	32%, maximum
Environmental stress crack	750 h, minimum
Water absorption	0.1 maximum and weight change
Hydrostatic resistance	316,000 kgf/m ²
Oxidation induction time (200 C/l atm. O ₂)	90 minutes

Reference: Construction Specifications (KEH 1990b). Format uses NSF 54 table for high-density polyethylene as a guide (NSF 1985). However, RCRA values for dimensional stability and environmental stress crack have been added.

% = percent
g = gram
min = minute
h = hour

max = maximum
kgf = kilograms force
m = meters
mm = millimeters

1

Table C.10. Drainage Gravel Specifications

Property	Value
Sieve size	
25 millimeters	100 wt% passing
19 millimeters	80 – 100 wt% passing
9.5 millimeters	10 – 40 wt% passing
4.75 millimeters	0 – 4 wt% passing
Permeability	0.1 cm/sec, minimum

2 Reference: Sieve size is from WSDOT M41-10-88, Section 9.03.1(3)C for Grading No. 5 (WSDOT 1988).

3 Permeability requirement is from [WAC 173-303-650\(2\)\(j\)](#) for new surface impoundments.

4

1

Figure C.2. Plan View of the 200 Area Effluent Treatment Facility

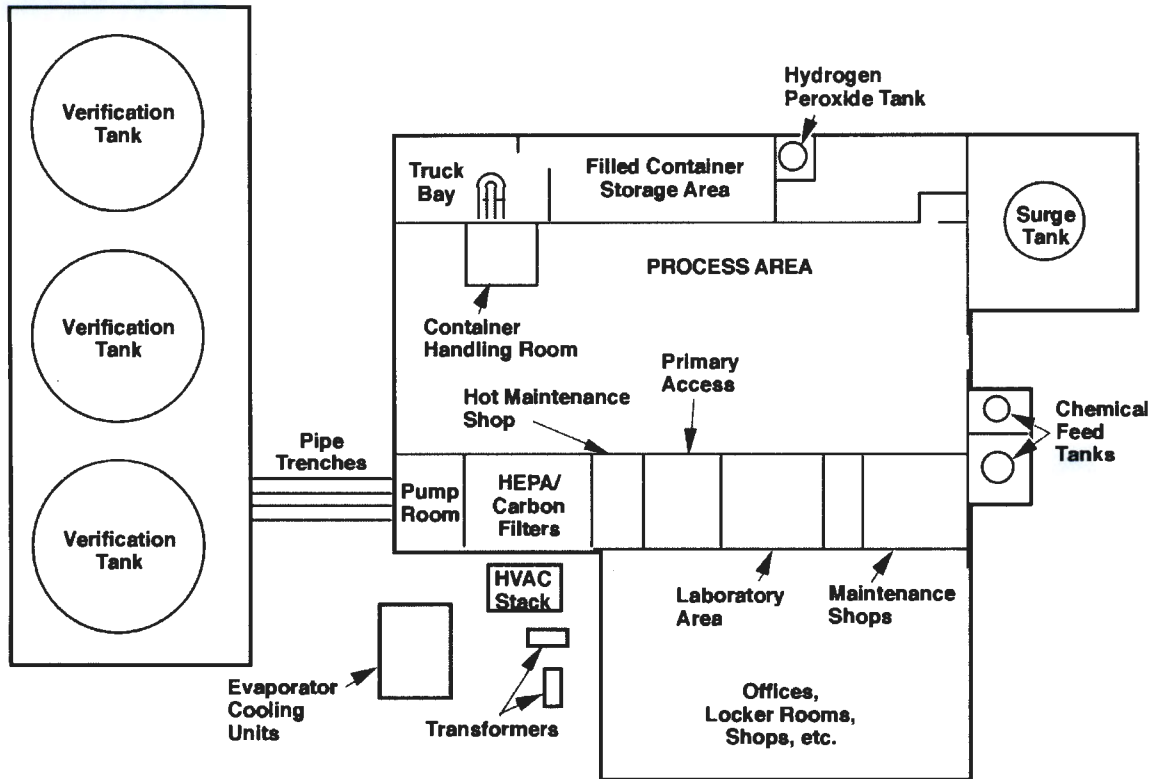

HEPA = High-efficiency particulate air
HVAC = Heating, ventilation, and air conditioning

M0704-3.6
4-24-07

2

3

Figure C.3. 200 Area Effluent Treatment Facility Layout

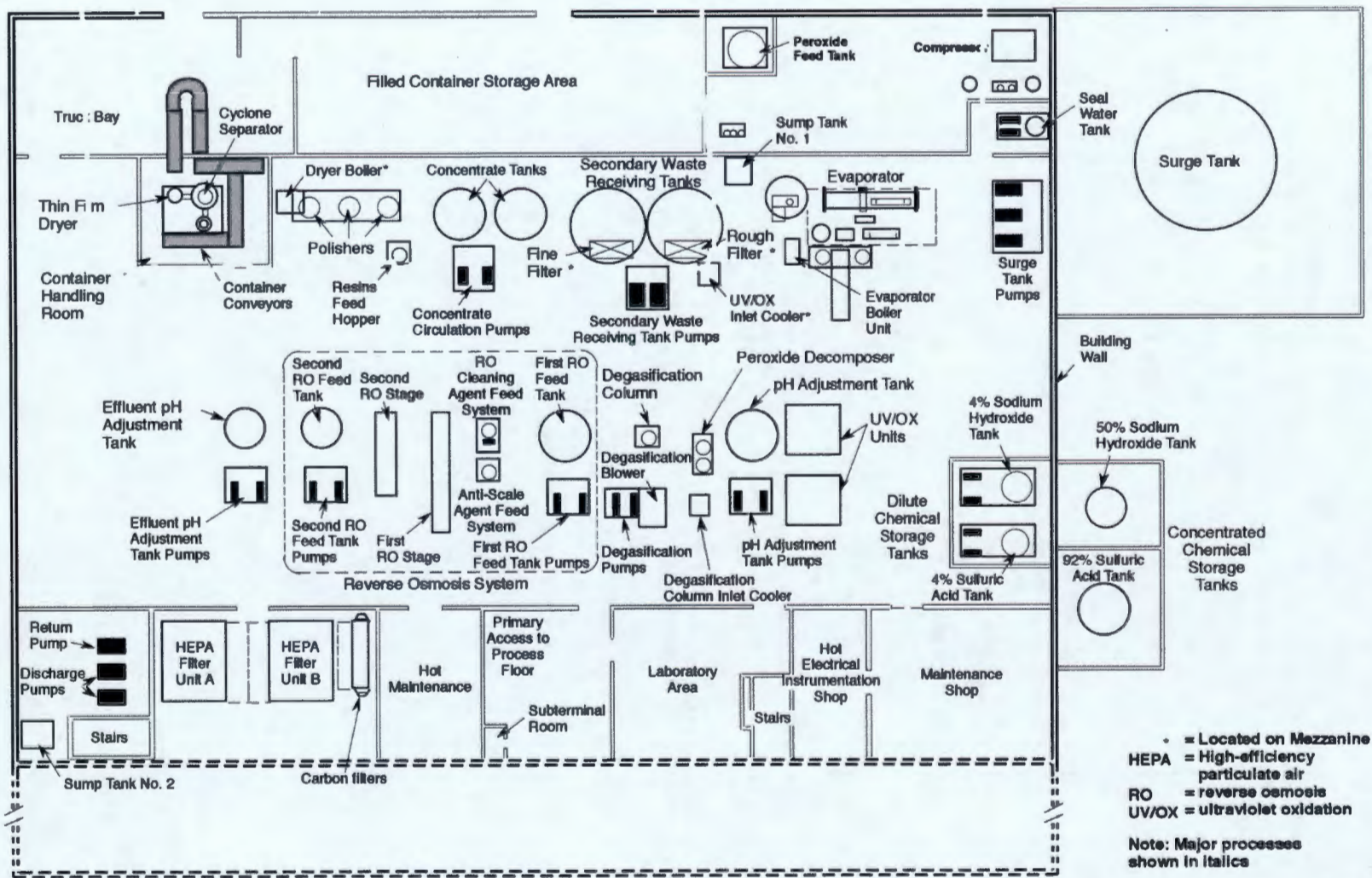

• = Located on Mezzanine
 HEPA = High-efficiency particulate air
 RO = reverse osmosis
 UV/OX = ultraviolet oxidation
 Note: Major processes shown in italics

M0704-3.1
 4-21-07

C.50

1

Figure C.4. 200 Area Effluent Treatment Facility

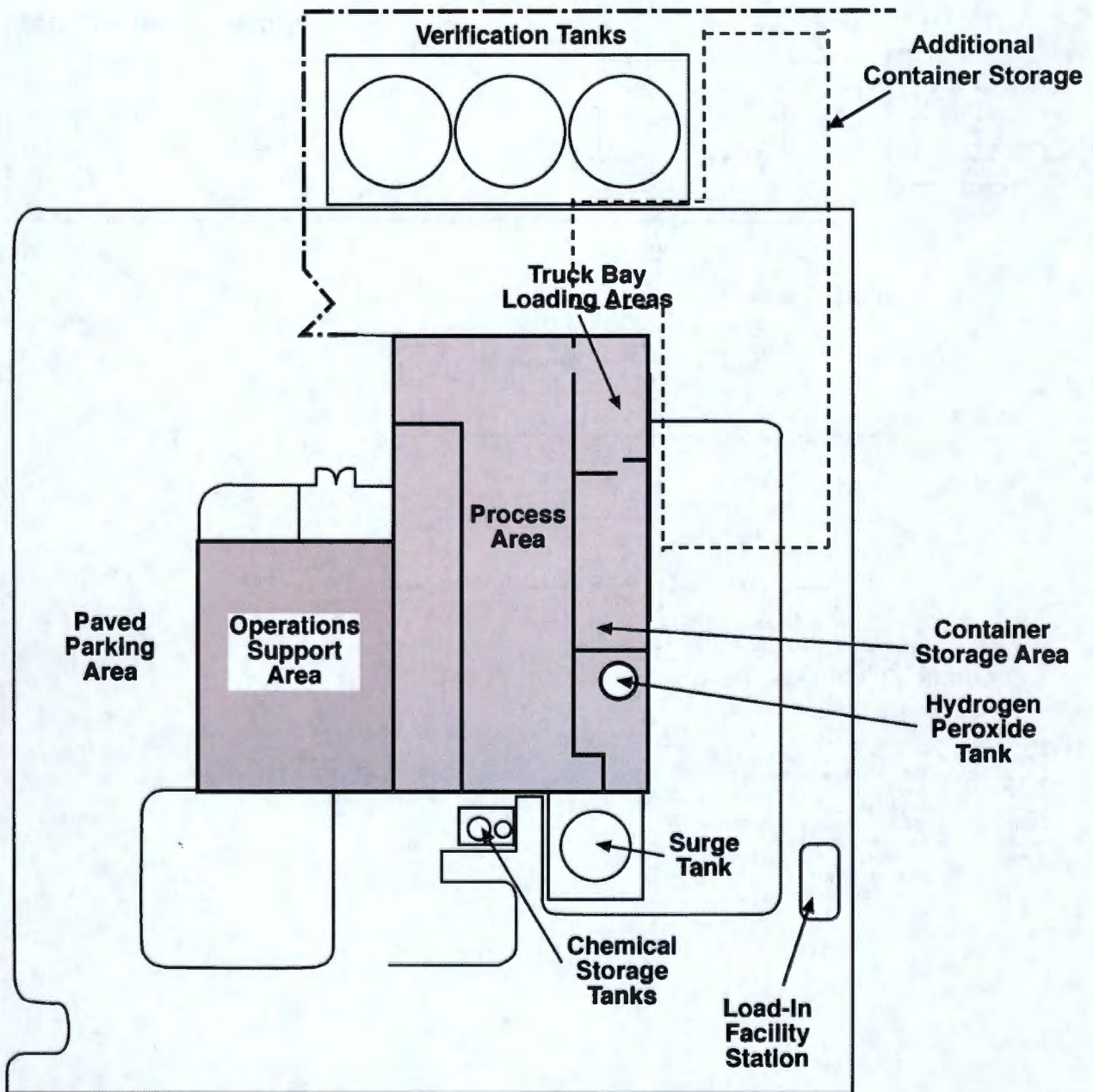

2

3

M0704-3.4
4-21-07

1 **Figure C.5. Example - 200 Area Effluent Treatment Facility Configuration 1**

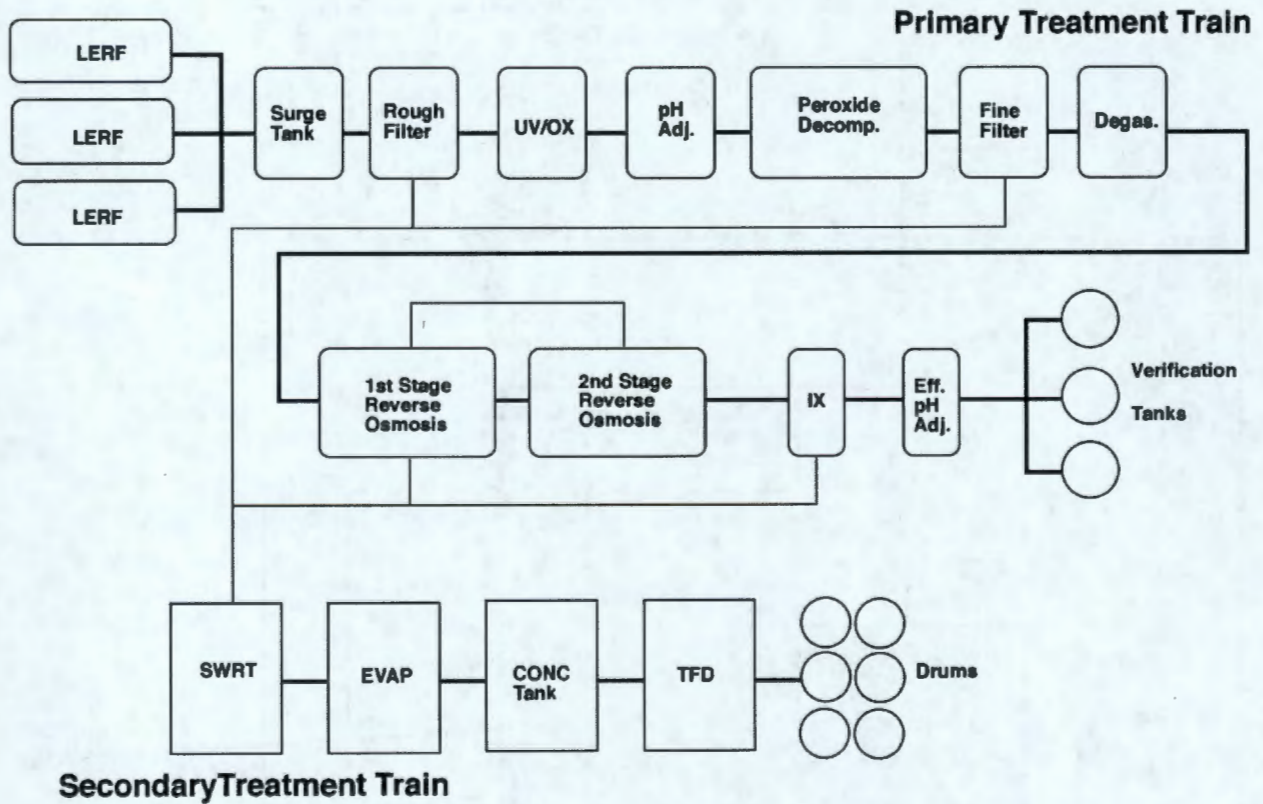

- CONC Tank = Concentrate tank
- Degas. = Degasification column
- Eff. pH Adj. = Effluent pH adjustment tank
- EVAP = Evaporator
- IX = Ion Exchange
- LERF = Liquid Effluent Retention Facility
- pH Adj. = pH adjustment tank
- SWRT = Secondary waste receiving tank
- TFD = Thin film dryer
- UV/OX = Ultraviolet Oxidation

M0704-3.B
 4-21-07

2

3

1 **Figure C.6. Example - 200 Area Effluent Treatment Facility Configuration 2**

2

3

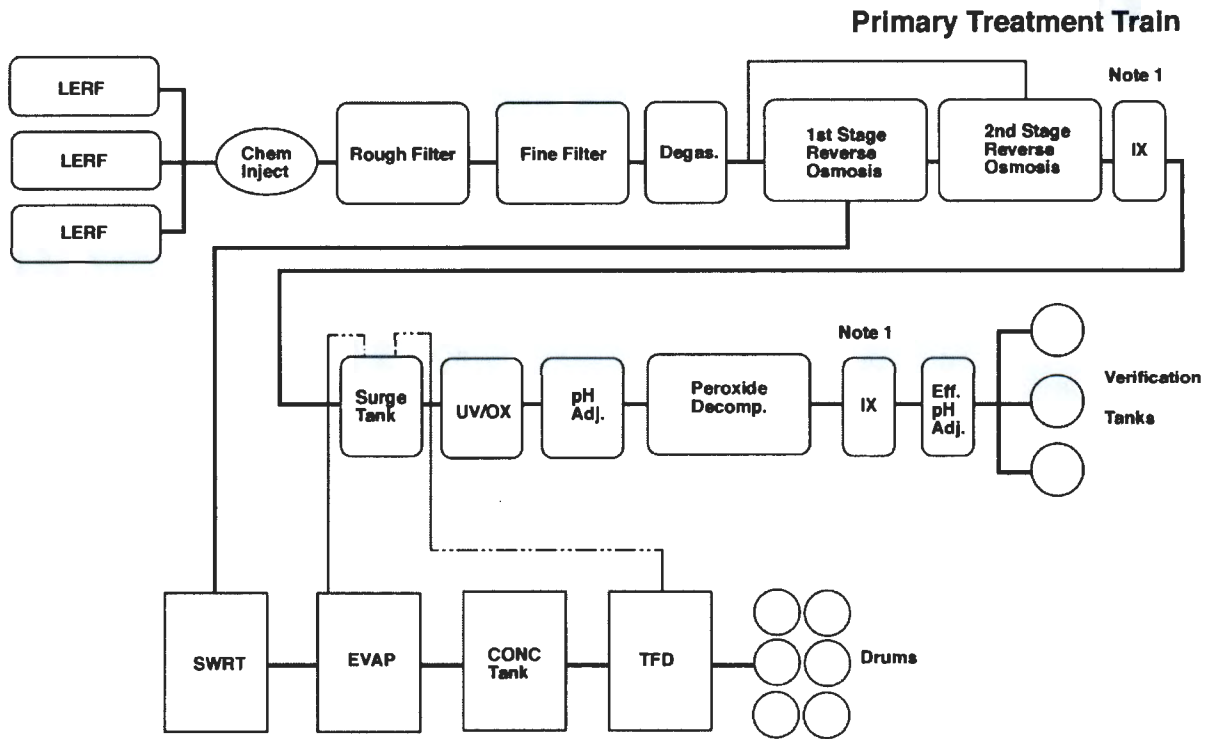

Secondary Treatment Train

- Note 1: IX can be in either location
- CONC Tank = Concentrate tank
- Degas. = Degasification column
- Eff. pH Adj. = Effluent pH adjustment tank
- Evap = Evaporator
- IX = Ion exchange
- pH Adj. = pH adjustment tank
- SWRT = Secondary waste receiving tank
- TFD = Thin film dryer
- UV/OX = Ultraviolet Oxidation

M0704-3.2
 4-21-07

1

Figure C.7. Surge Tank

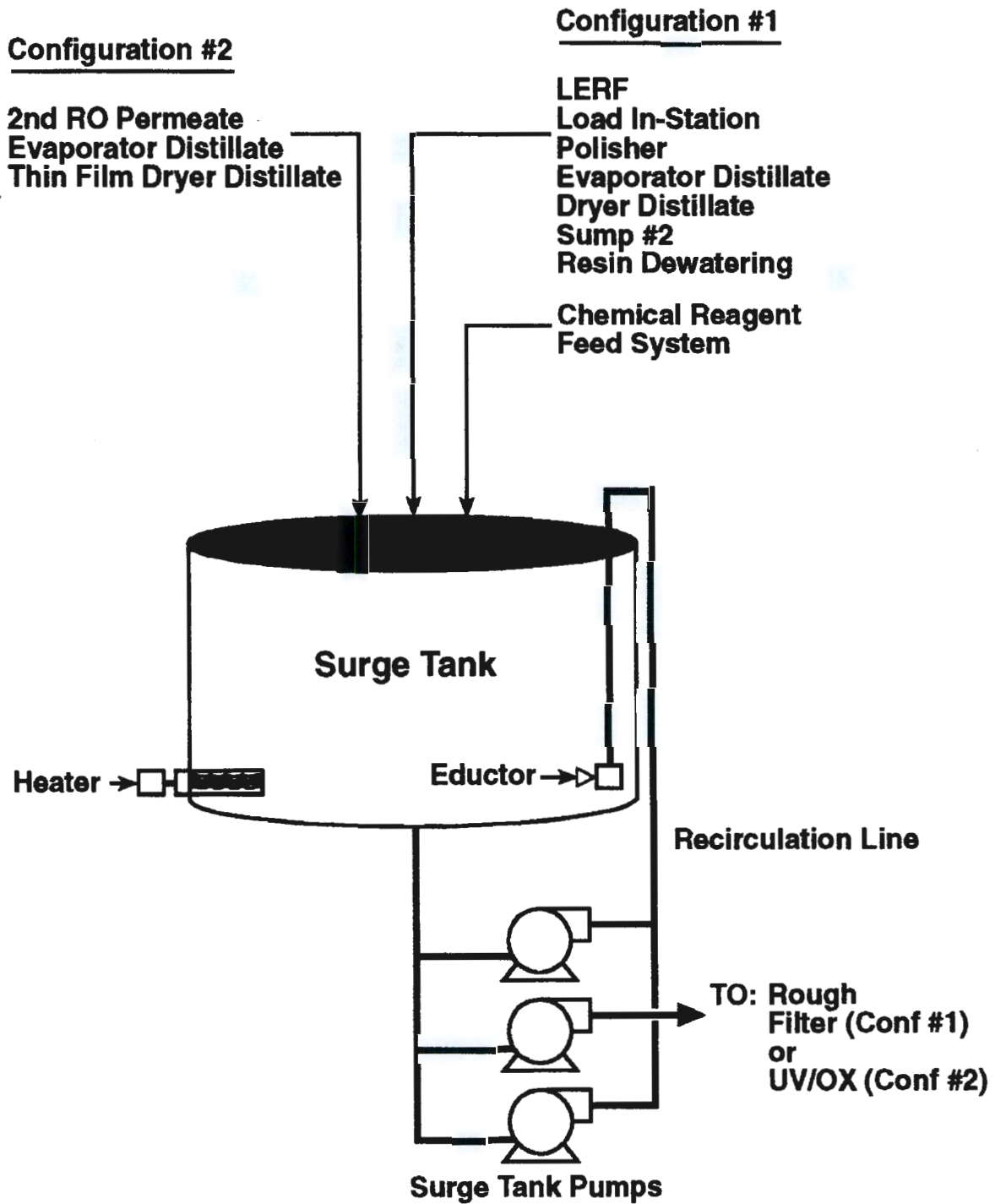

H97040165.19
R1

2

3

1

Figure C.8. Ultraviolet Light/Oxidation Unit

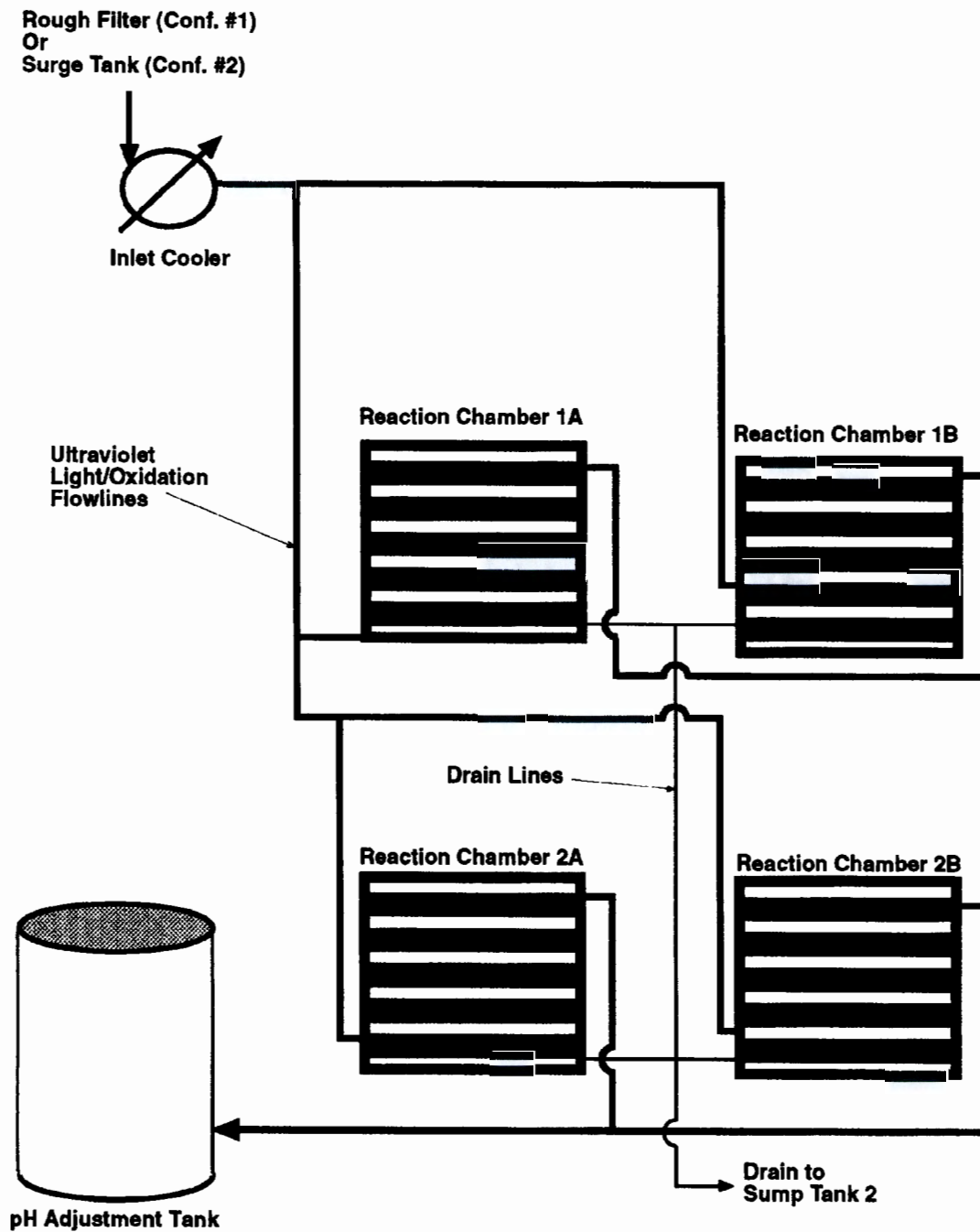

H97040165.20

2

3

1

Figure C.9. Reverse Osmosis Unit

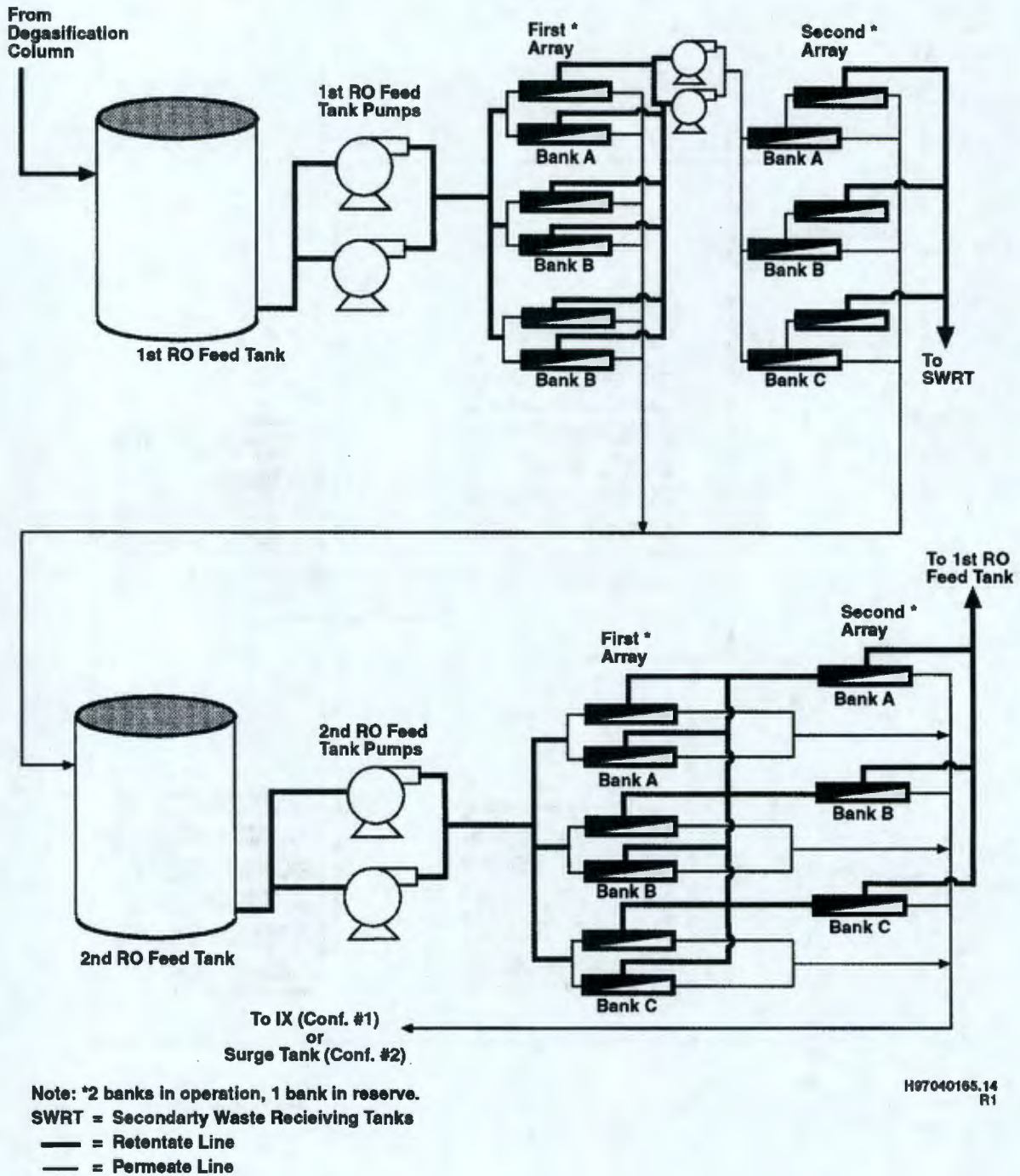

2

3

1

Figure C.10. Ion Exchange Unit

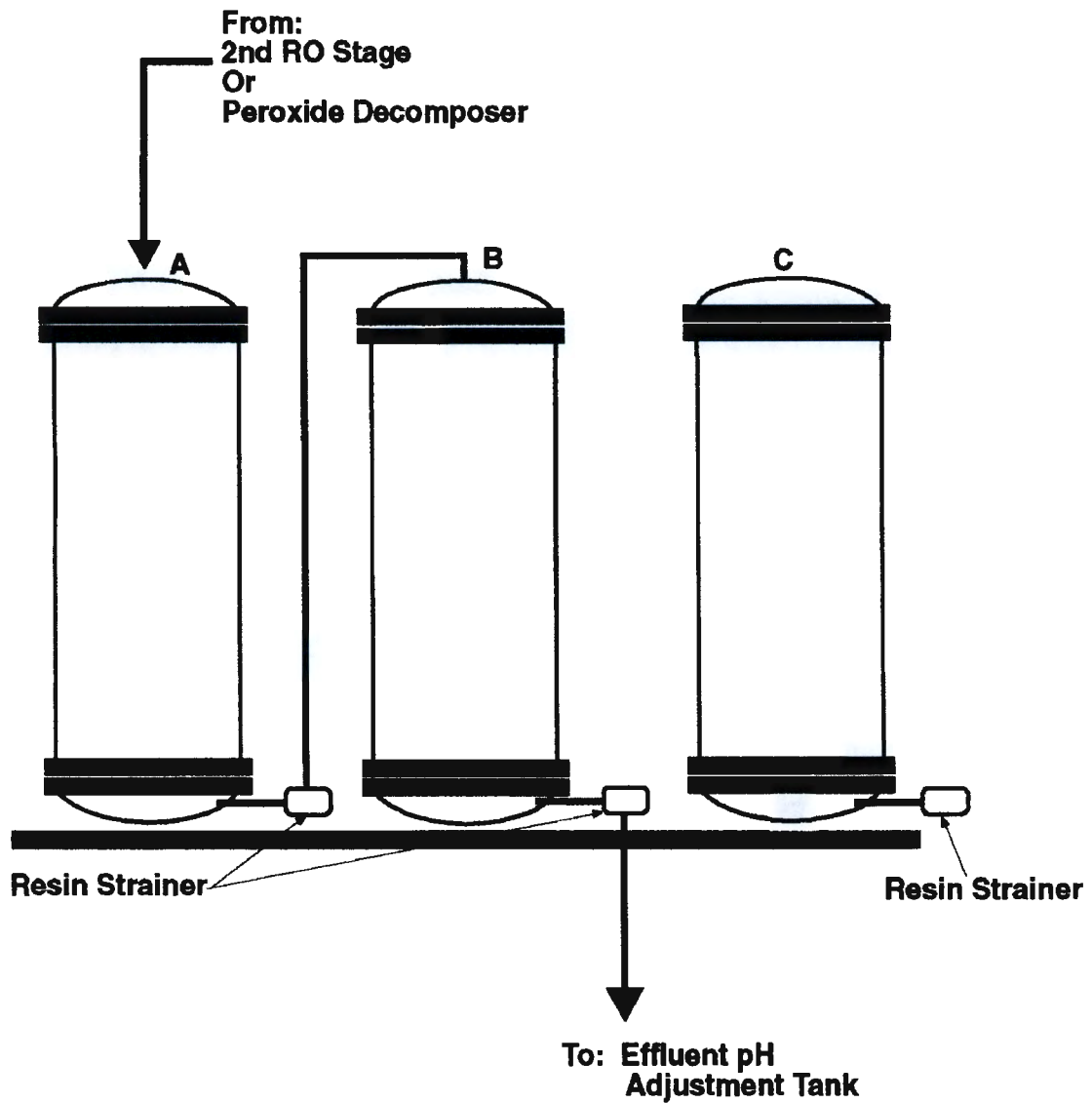

**NOTE: Example Configuration- Column A and B in Operation,
Column C in Standby Mode**

H97040165.18

2

3

1
2

Figure C.11. Verification Tanks

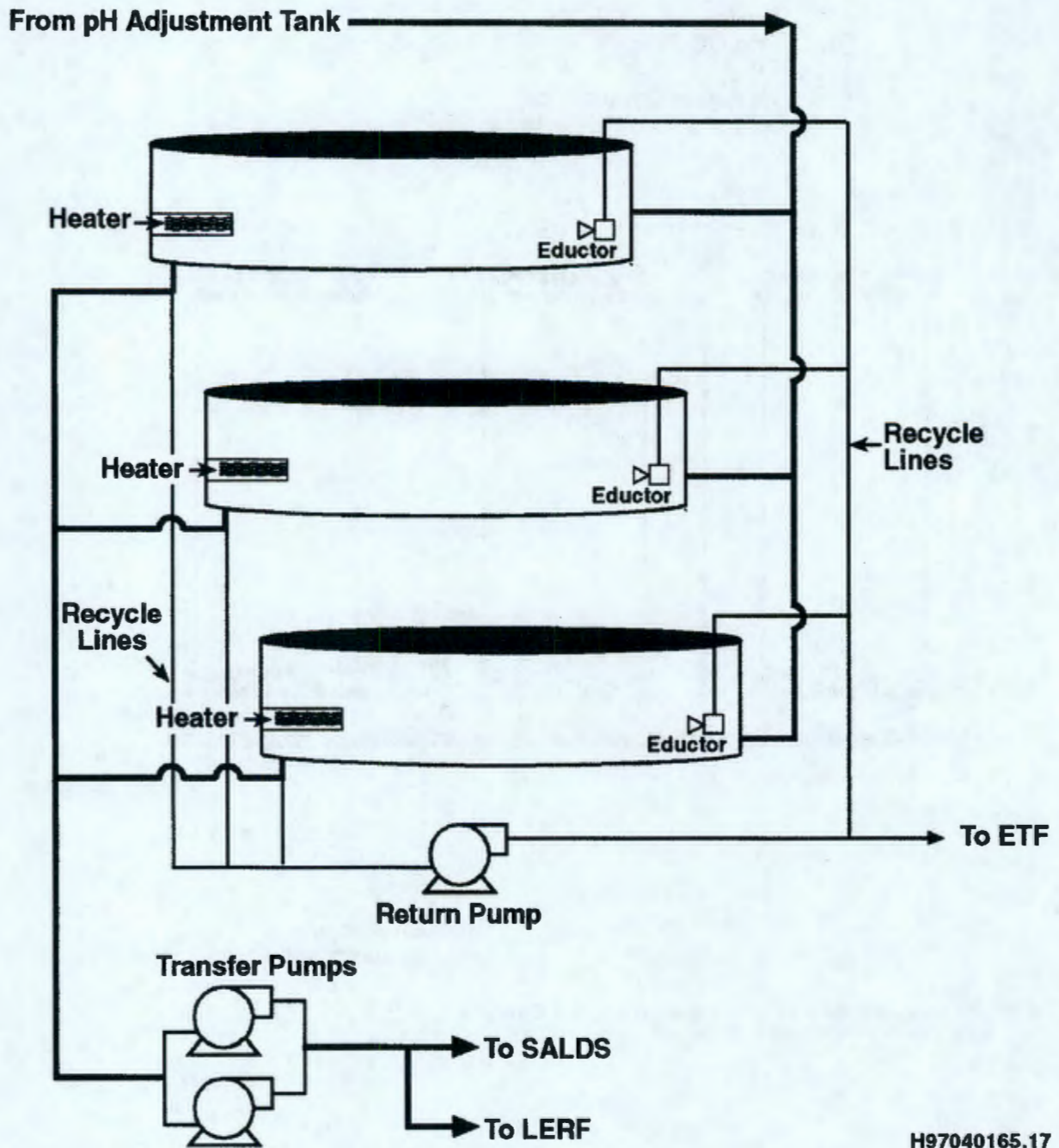

H97040165.17
R1

1
2

Figure C.12. Effluent Treatment Facility Evaporator

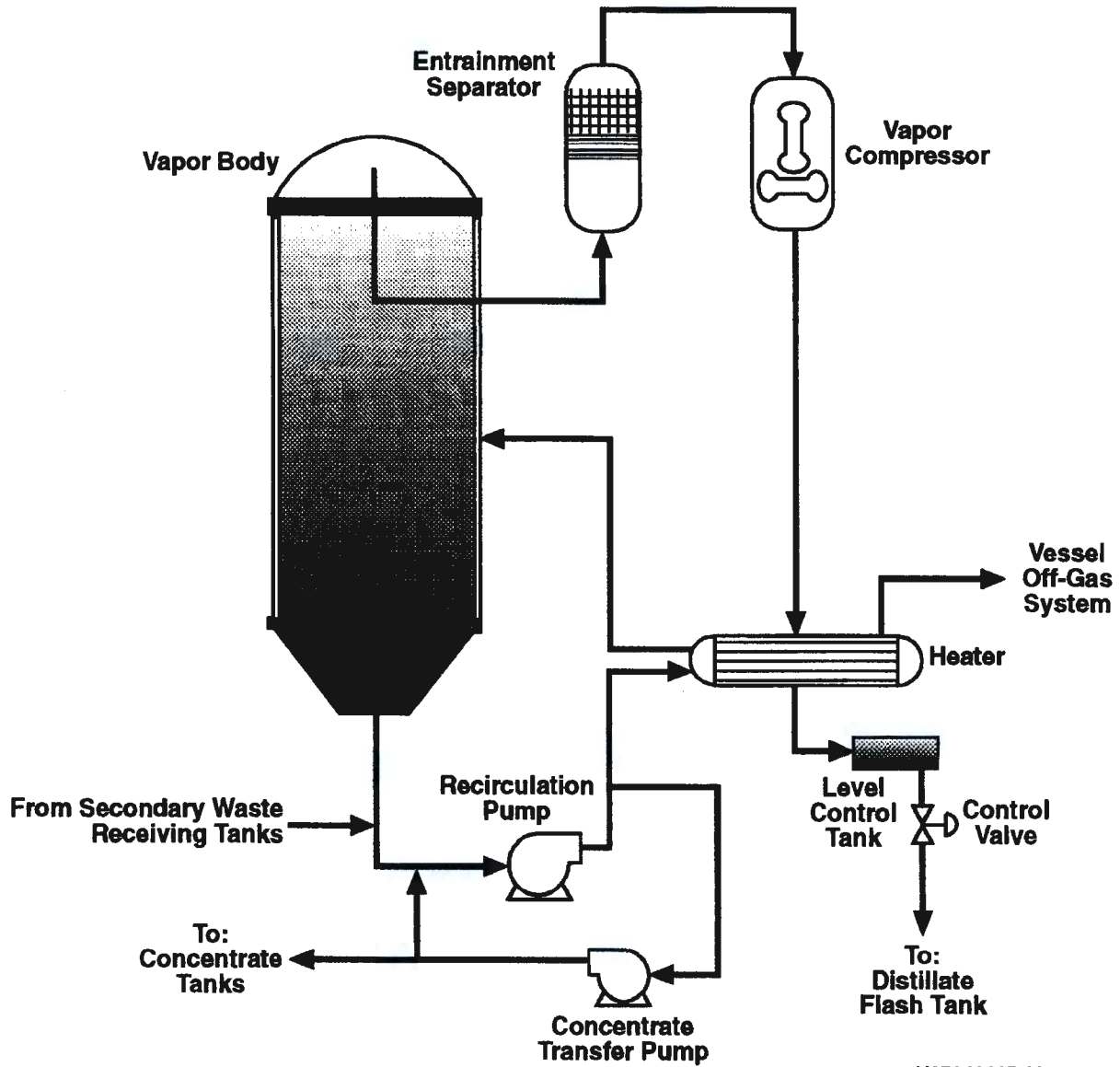

H97040165.10
R2

1
2

Figure C.13. Thin Film Dryer

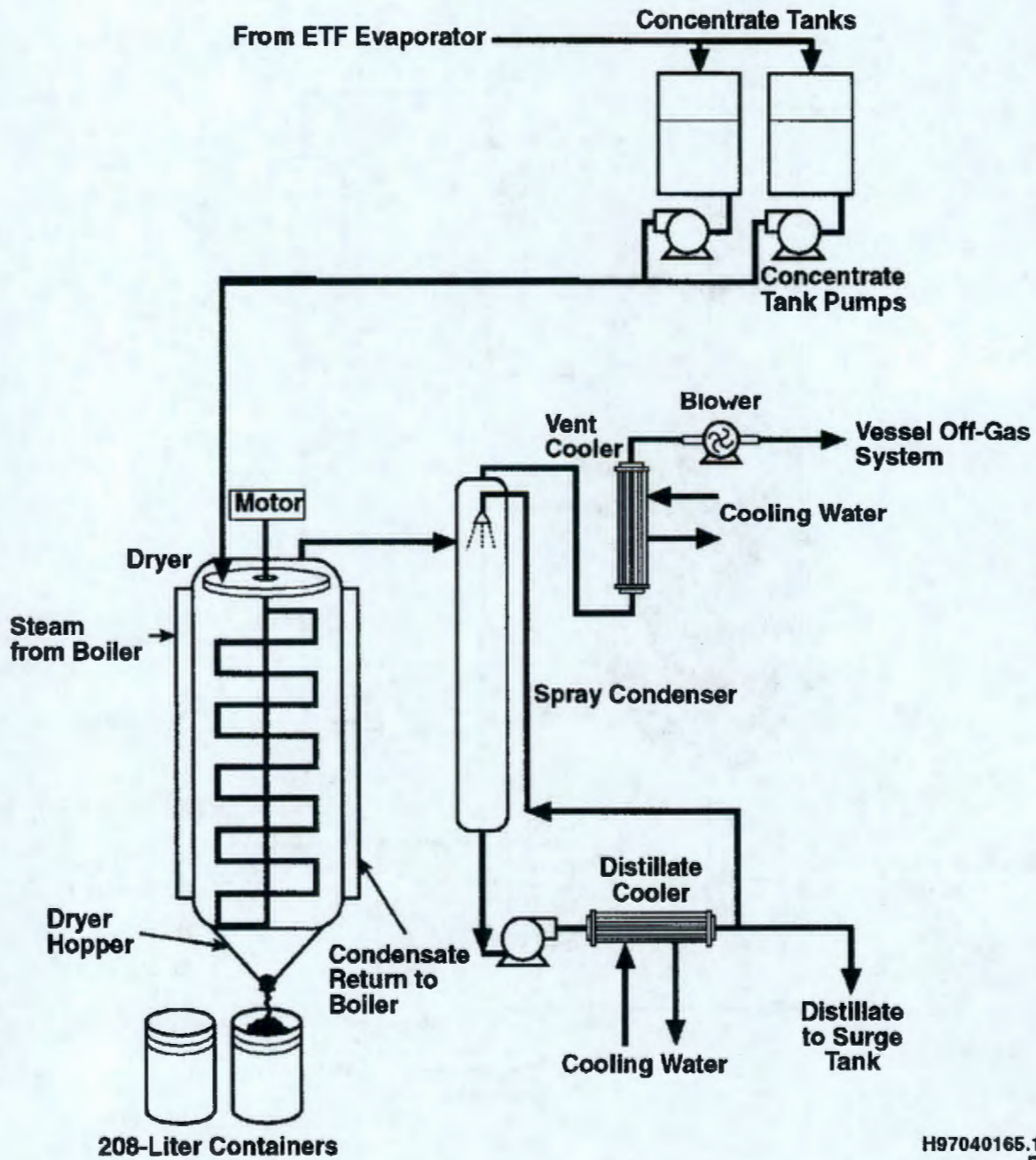

H97040165.16
R1

1
2

Figure C.14. Container Handling System

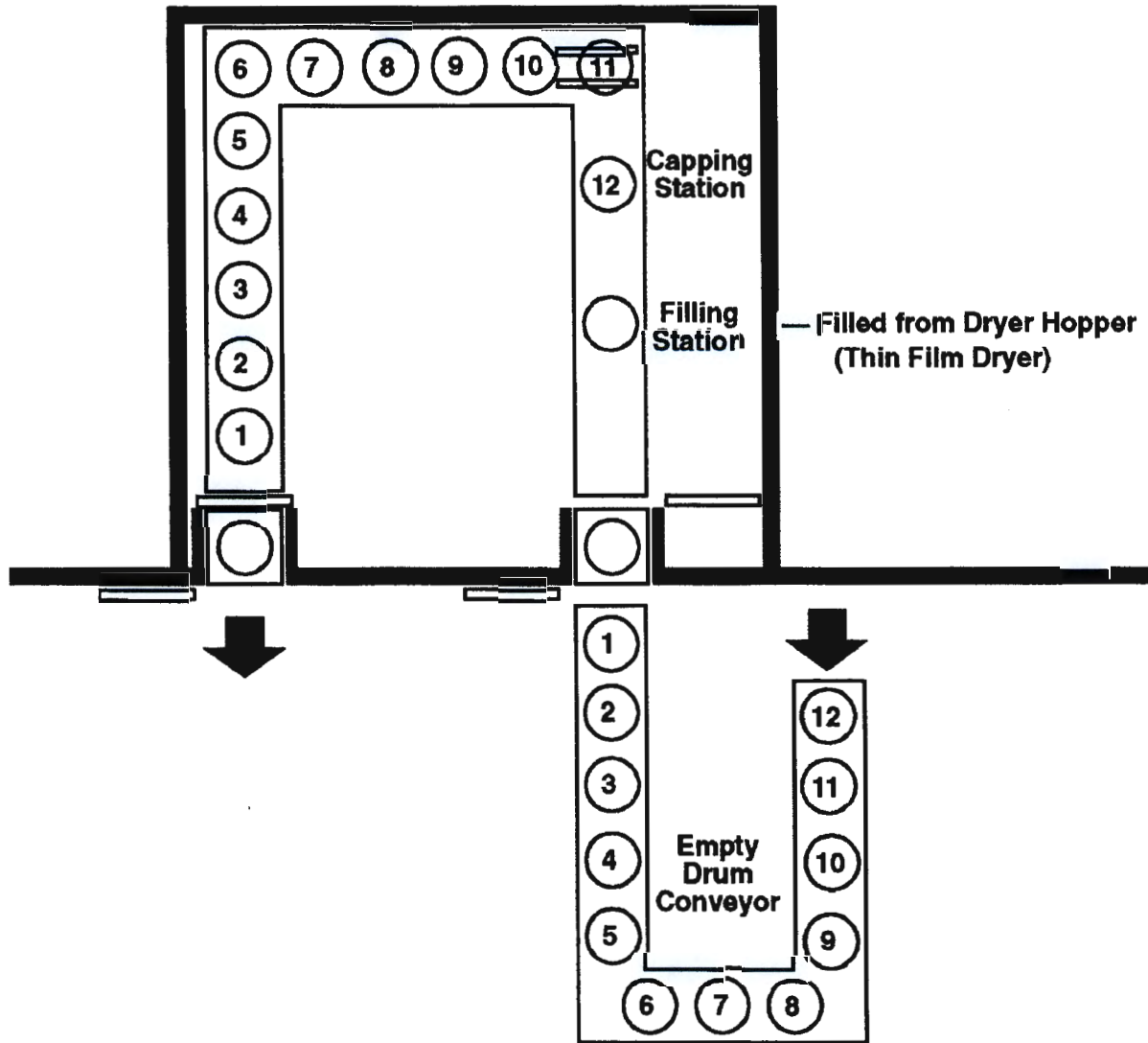

H97040165.15
R1

1
2

Figure C.15. Effluent Treatment Facility Sump Tanks

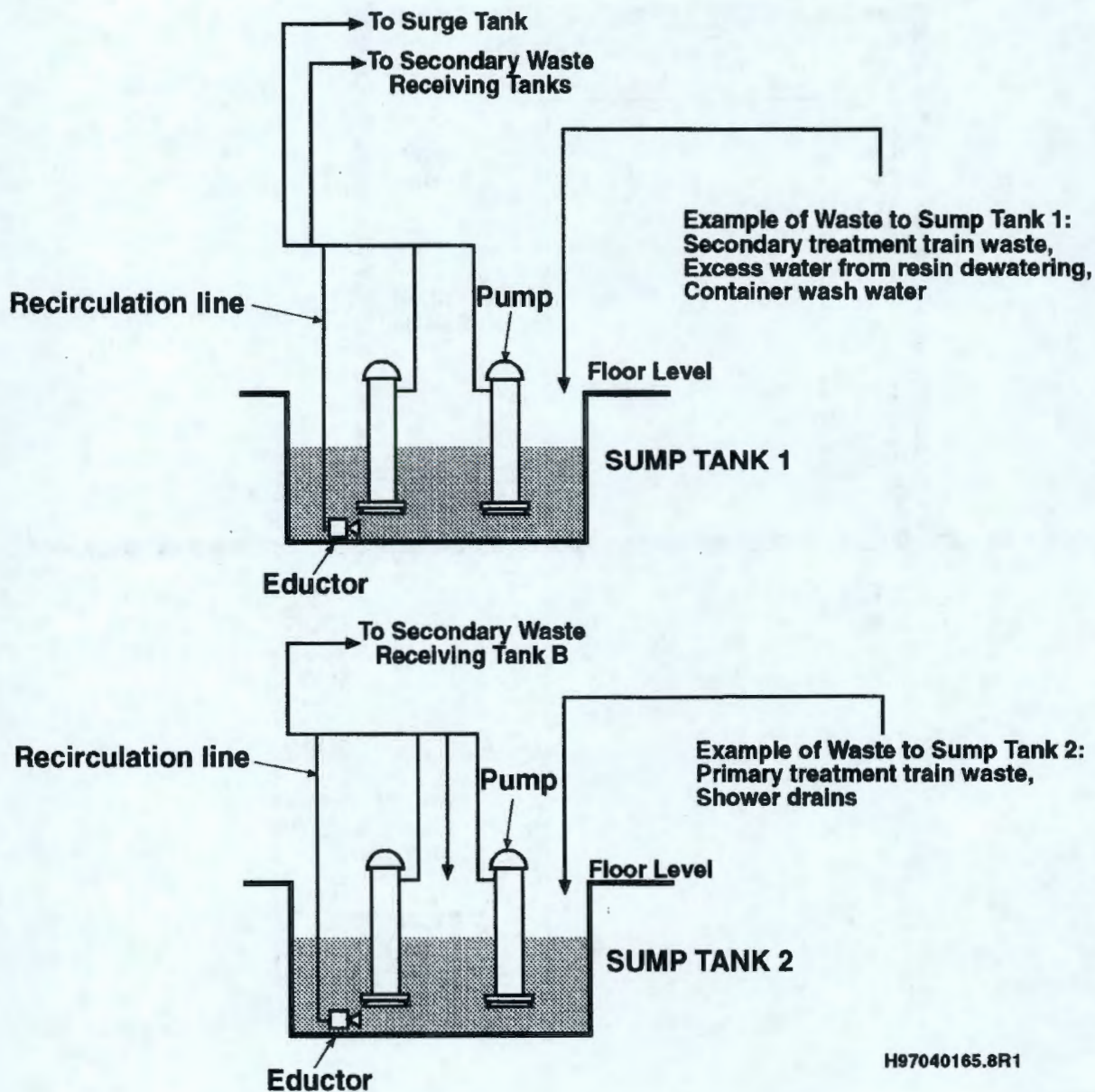

1
 2
 3

Figure C.16. Liner Anchor Wall and Cover Tension System

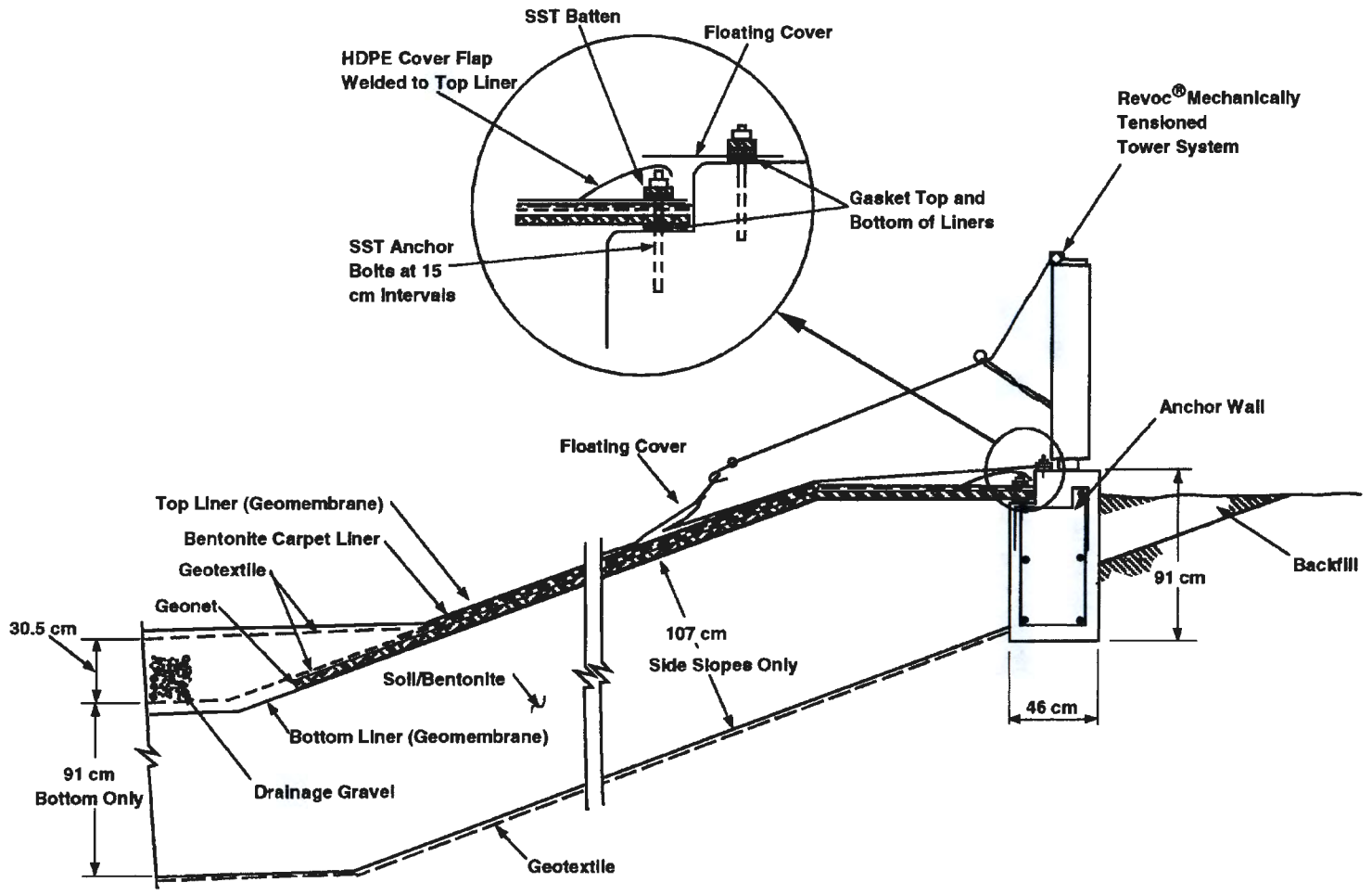

® = Patented and licensed by CW Neal Corp, Santee, CA
 Not to Scale

H97040165.4

C.63

1
2

Figure C.17. Liner System Schematic

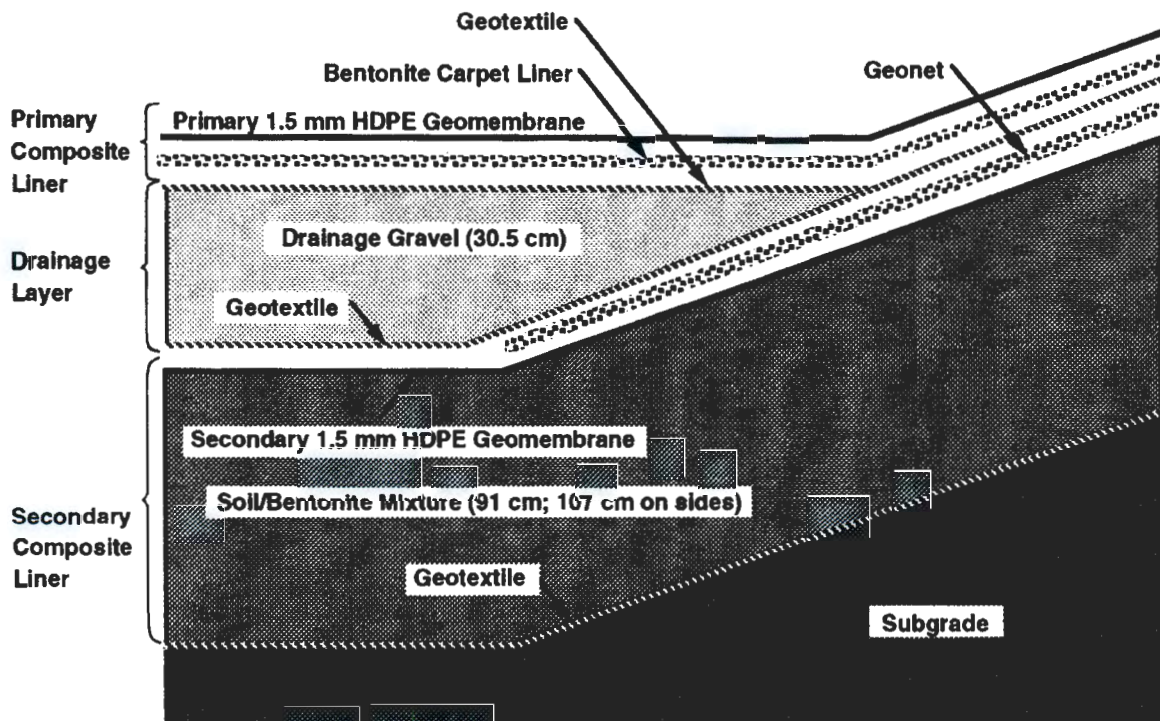

Not to Scale

H97040165.1

1
2
3

Figure C.18. Detail of Leachate Collection Sump

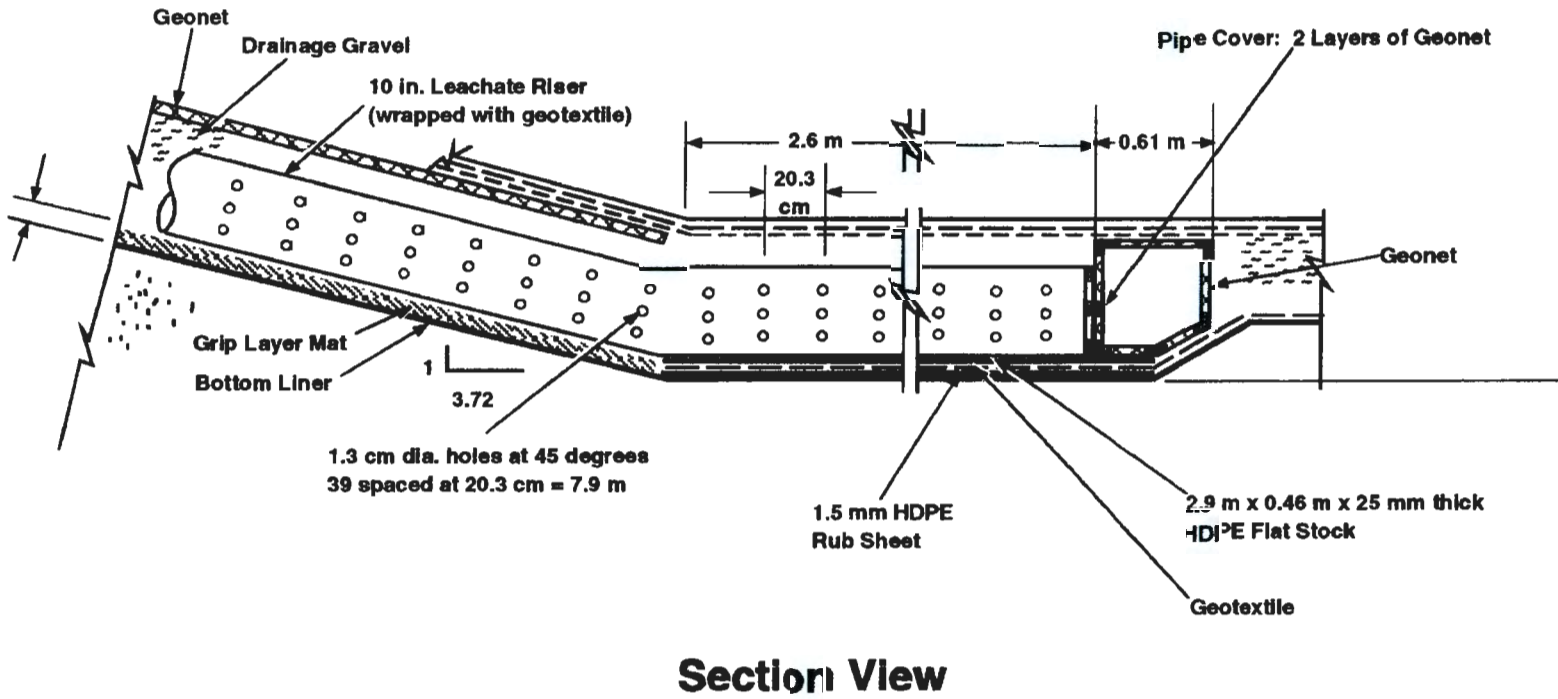

HDPE: High Density Polyethylene
Not to Scale

H97040165.3

C.65