



OFFICE OF  
**RIVER PROTECTION**  
United States Department of Energy

# Tank Side Cesium Removal Demonstration Project

Presented by: Sahid C. Smith, U.S. Department of Energy, Office of River Protection

March 2019



- External Independent Review Team recommended two-phased pretreatment strategy
  - Tank Side Cesium Removal (TSCR) system as a “first feed” solution
  - Optimized Low-Activity Waste Pretreatment System (LAWPS) for long-term Low-Activity Waste (LAW) Vitrification feed
- Subsequent U.S. Department of Energy (DOE) direction to suspend LAWPS facility design; perform future alternative analysis to determine long-term feed solution
- DOE issued a request for proposal (RFP) for Technology Demonstration of TSCR capability
  - Provide system to meet LAW Vitrification waste acceptance criteria
  - Enable LAW Vitrification to complete hot commissioning by 12/21
  - Enable initial LAW Vitrification operations until LAWPS becomes operational
  - Use relevant information from Savannah River’s tank closure cesium removal (TCCR) demonstration
  - Leverage experience from commercial nuclear waste cleanup projects

## **Tank side cesium removal system will remove suspended solids and cesium from double-shell tank (DST) liquids to provide LAW feed to the Waste Treatment and Immobilization Plant (WTP)**

- The initial phase is a “proof of concept” demonstration that has a target of loading the first set of columns with approximately 100,000 curies (Ci) of cesium
  - Evaluate the selected ion exchange (IX) resin removal efficiency performance
  - Achieve a decontamination factor (DF) of greater than 1000
  - First campaign will produce about 170K gallons of feed
- The second phase would target up to an additional 5 million gallons of waste in order to validate overall operability of the system including reliability and unit efficiencies
  - Increase column loading while maintaining >1000 DF
  - Increase Total Operating Efficiency
  - Prove Crystalline Silicotitanate kinetics
  - Proving filter operation and cleaning (simulant vs. real waste)
  - Prove the ability for continued operations using replaceable columns
  - Demonstrate column transportability, and
  - Use process knowledge to sustain operations

# TSCR Conceptual System Diagram

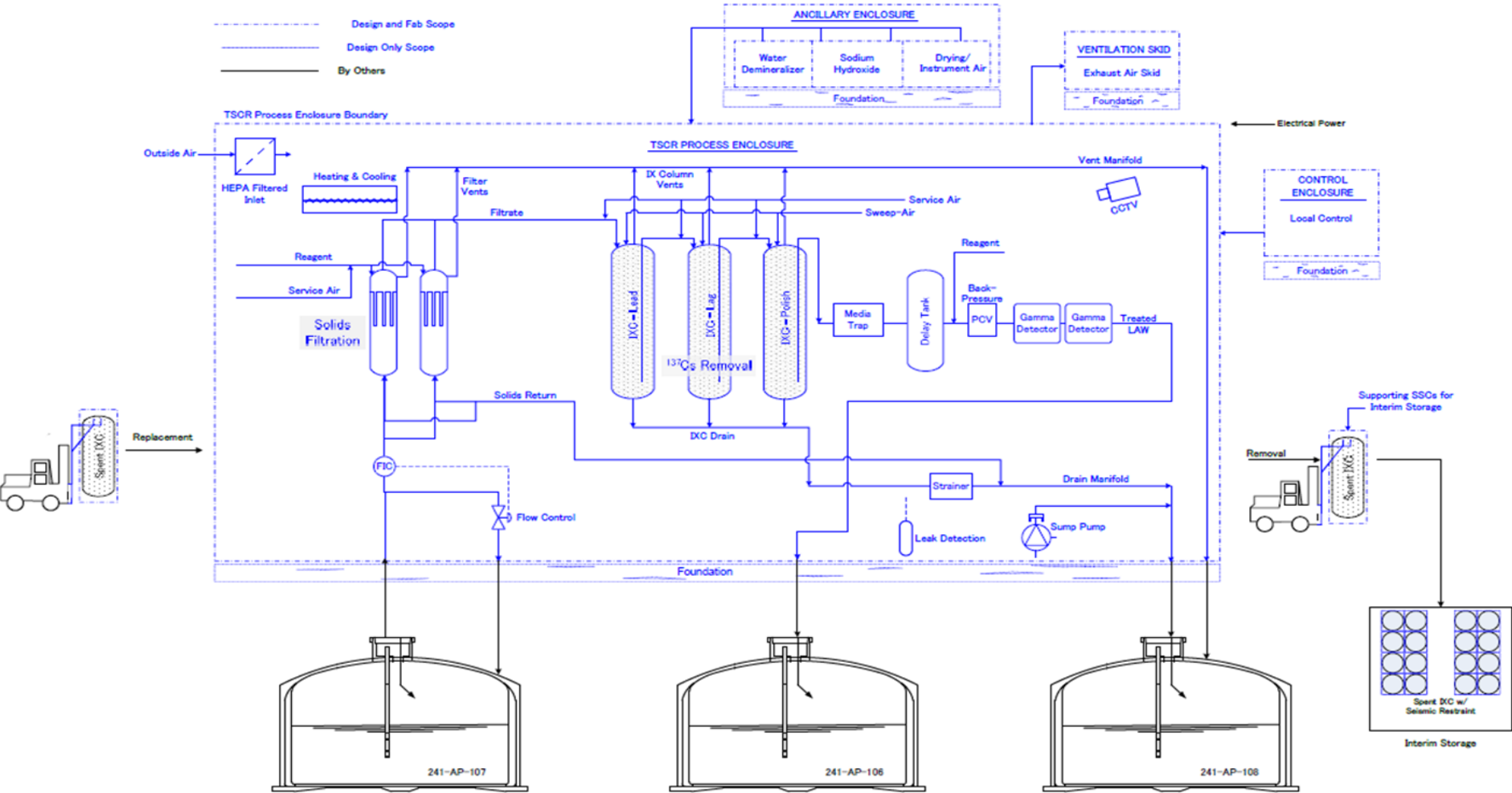

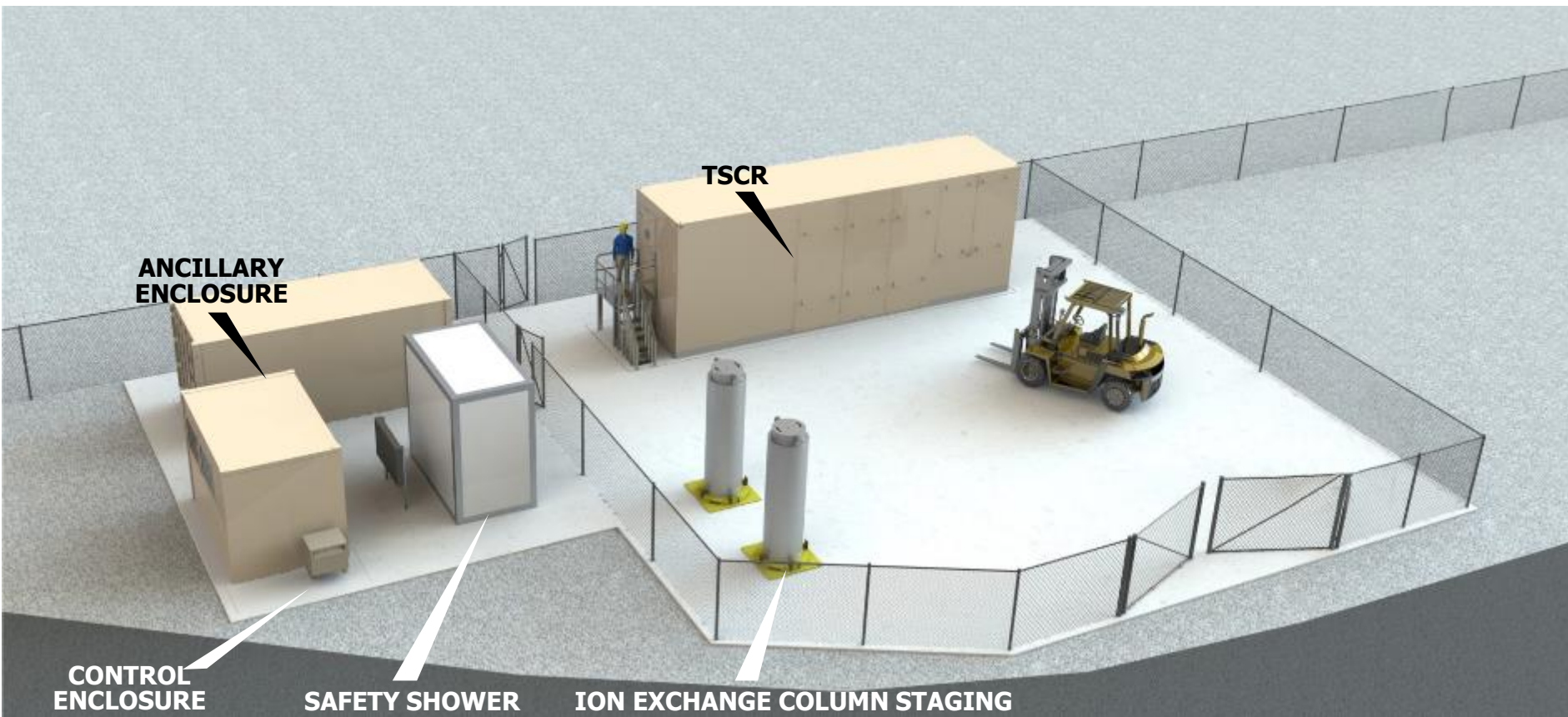

**On track for Producing Feed for DFLAW Operations as soon as 2022**

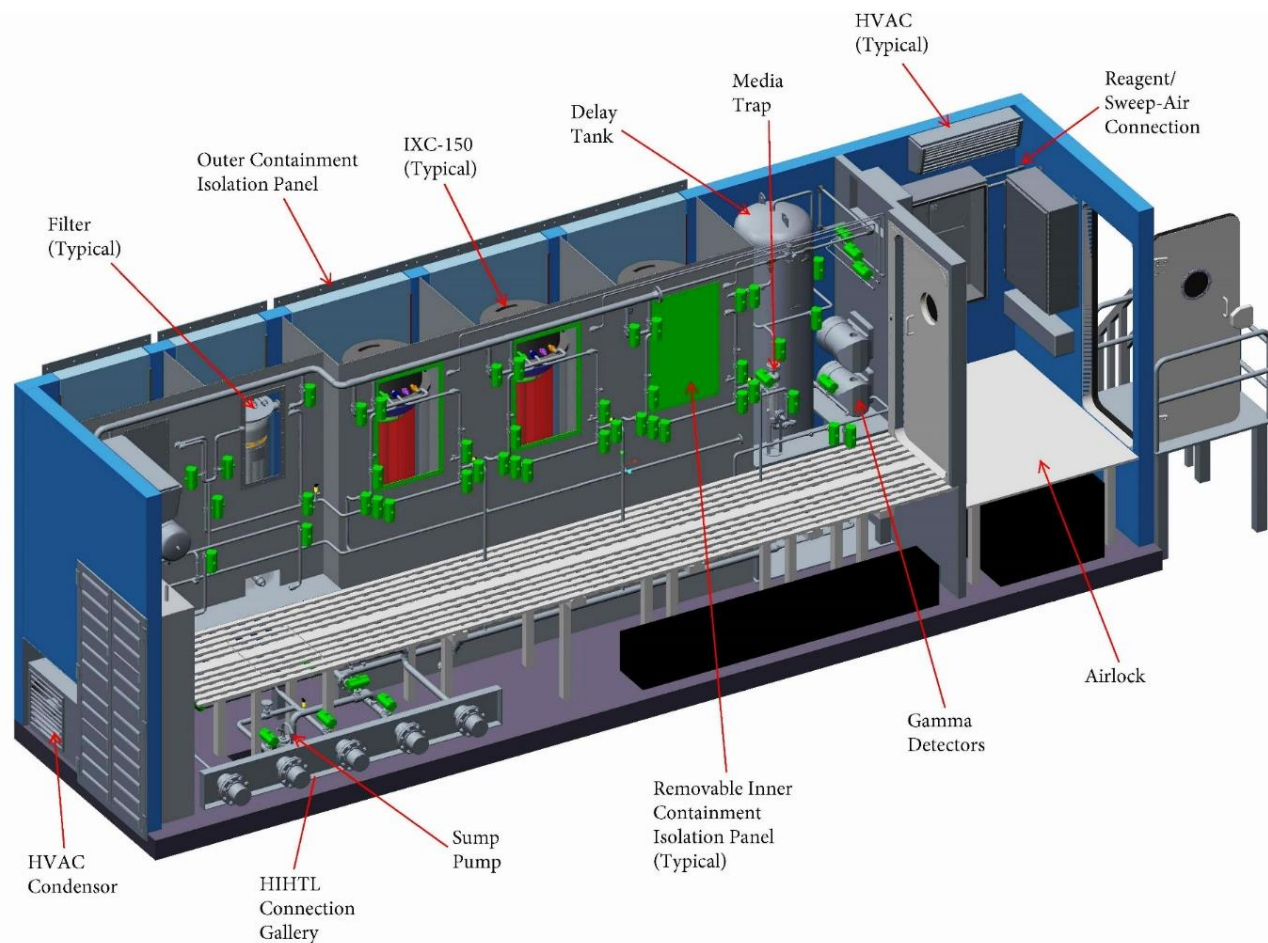

## Key Metrics:

- 5-gpm
- 5.6M Na+ Waste
- 160 ppm UDS
- 20 to 35°C
- 0.163 Ci/L <sup>137</sup>Cs (process)
- 0.30 Ci/L <sup>137</sup>Cs (safety)

## Performance

- <sup>137</sup>Cs DF of  $\approx 1000$
- $H_2 < 0.25$  LFL
- No boiling at Atm
- Phase 1 – 170,000 gal
- Sys Availability > 70%

## 1 Center Cooling Core Creates Annular IX Bed

- Eliminates high temperature center-line region of ion exchange column (IXC)
- Creates convective air flow in the core increasing decay heat dissipation
- Annulus created by core limits horizontal bubble migration and bubble agglomeration
- Significantly lowers overall operating temperature increasing gas solubility in liquid while reducing G-Value
- Rated for 669 W of decay heat
- IXC base and top designed to allow full natural convection flow while maintaining shielding

## 2 Resin Port and Shield Plug

- 4-in. port to facilitate resin fill and future removal

## 3 Vent Design

- The vessel vent incorporates a "high-point" cavity ensuring gas migration to the vent
- Wedgewire screen provides large surface area for gas migration while precluding the release of resin

## 4 IX Column Internal Design

- Ensures even distribution of flow
- Mitigates channeling and other flow maldistributions
- Plug flow ensures full media utilization and minimizes Cs leakage
- Sized to retain 300 to 800  $\mu\text{m}$  resin beads
- Bottom (effluent) screens take effluent from within 1/2" of the flat vessel bottom maximizing CST and dewatering efficiency

## IXC-150

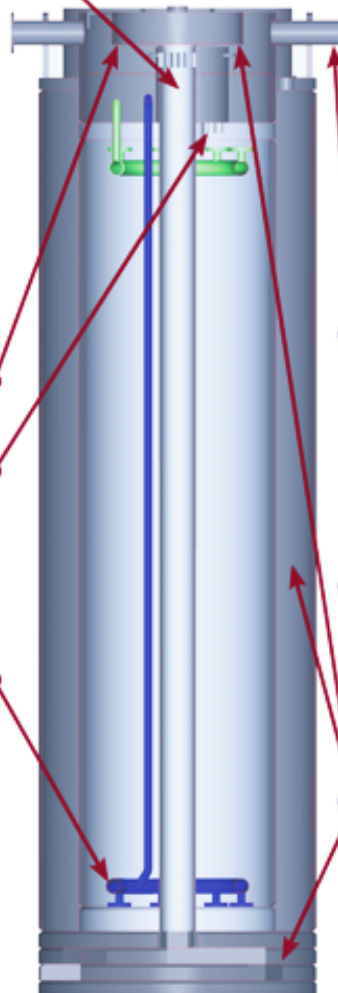

## 5 Proven Experience

- Treating liquid waste with Cs concentration up to 0.5 Ci/gal
- 400+ Mgal treated
- 5+ megacuries Cs removed
- 175 IX columns provided in 6 years
- Creates 15 times less waste than competing technologies at Fukushima
- Nozzle screens are structurally strong and mounted to minimize the moment arm - no failures in 18 years of operations

## 6 Simplified - Safe Handling/Exchange

- Integral lifting trunions for safe handling
- Maximum lift height limited to <6 in. minimizing drop scenarios
- ChemJoint connections minimize worker time to make fast leak-free connections during exchange

## 7 CST Resin Design Compatibility

- Small amount of freeboard above packed media bed limits radiolytic gas accumulation and potential for episodic gas release
- Loading capacity of over 140,000 Ci  $^{137}\text{Cs}$

## 8 Integral Shielding Design

- Limits contact dose to <5 mrem/hr allowing personnel access to the IX columns
- Minimizes space for the IX column
- $\approx 5$  in. lead equivalent

- Flow Path
  - Bottom feed / Self-Venting
- Polypropylene Filter Media
- Filter Metrics
  - Extremely low flux
    - 9 GFD (0.00625 gpm/ft<sup>2</sup>)
  - 4 μm pore size
  - 24 filter – 2 5/8 inch diameter X 30 inch length
- Air Receiver (20 gal.) supplies motive force for backwash
  - Empties filter housing and related piping into AP-108



- Retains CST media in event of lateral failure
- Design Metrics
  - 0.003 inch (75  $\mu$ m) Screen Slot
  - < 0.2 psid at 5 gpm
  - All Welded Construction
  - Self Venting
- Bottom Nozzle
  - Allows maintenance backwashing without sending media to DST
- Replaceable

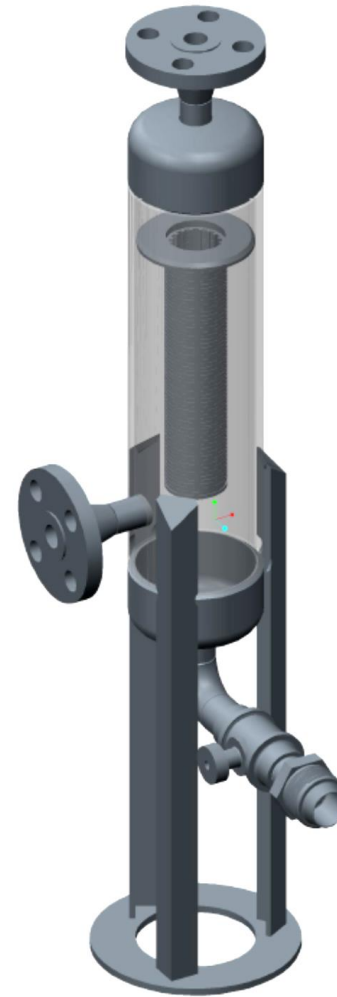

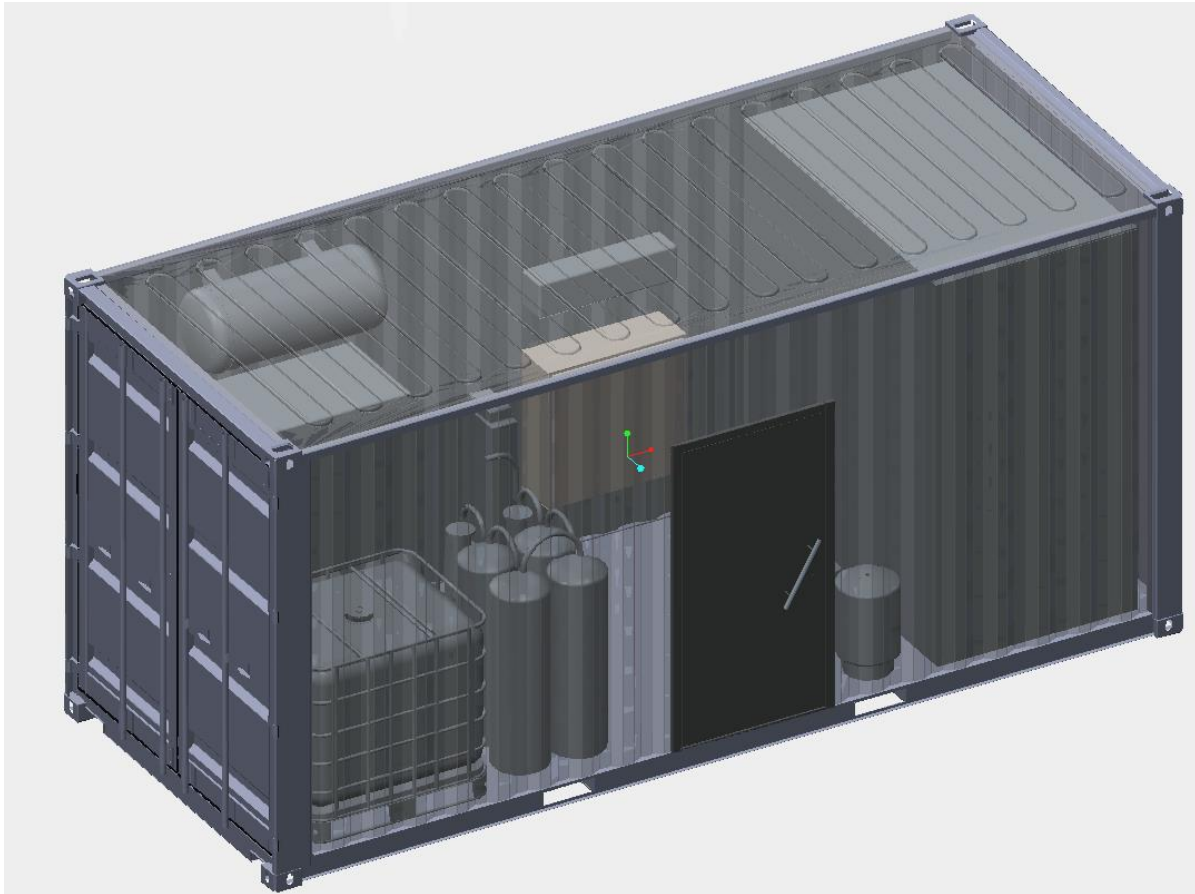

## Key Components:

- Air Compressors
- Air Dryer
- Receiver Tanks
- Potable Water Tank & Pump
- Potable Water Demineralizer
- Sodium Hydroxide (Reagent)
- Caustic Metering Pump

## Features:

- Insulated/ Heated
- Side Personnel Door
- Rear Cargo Door

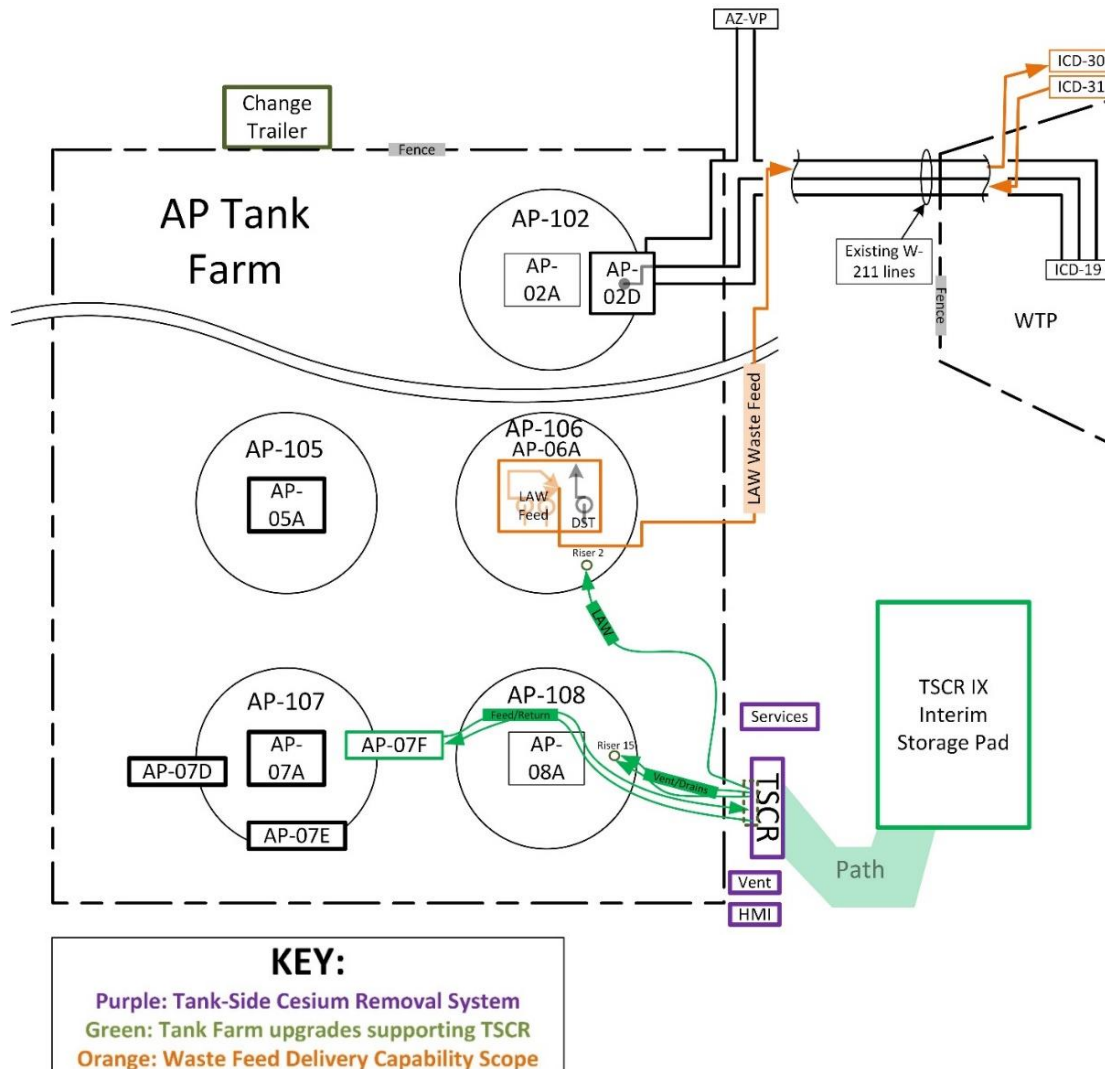

- Design, fabrication and field work for waste transfer from tanks to TSCR (transfer line, shielding, pump, jumpers, valves, and cover plate)
- Design, fabrication and field work for waste return, TSCR IXC vent, plant wash, and treated waste from TSCR to tanks (transfer line, shielding, adapter/drop leg)
- Fieldwork and construction of TSCR concrete pad
- Design, fabrication, and fieldwork for waste transfer system from WTP feed tank to the W-211 transfer lines

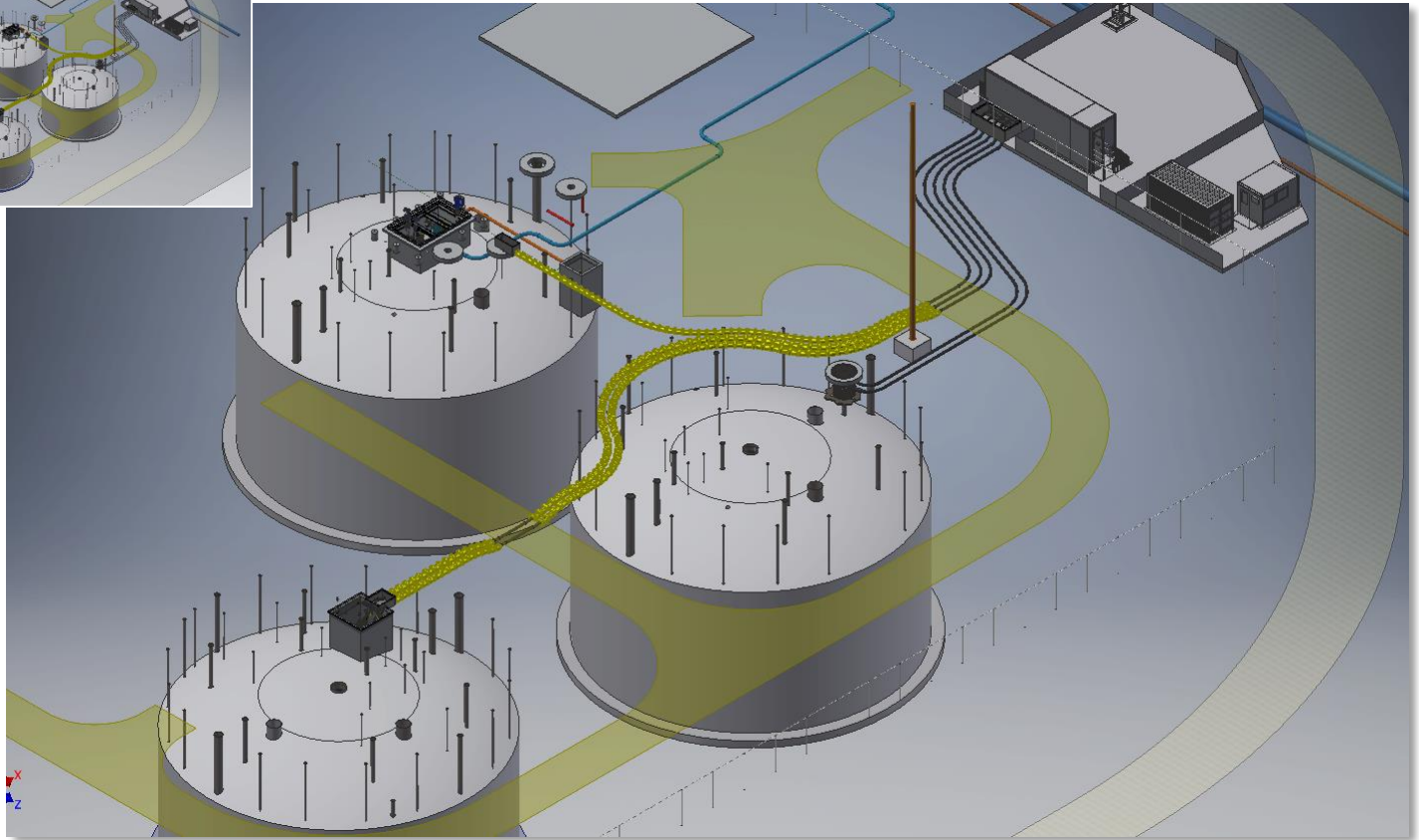
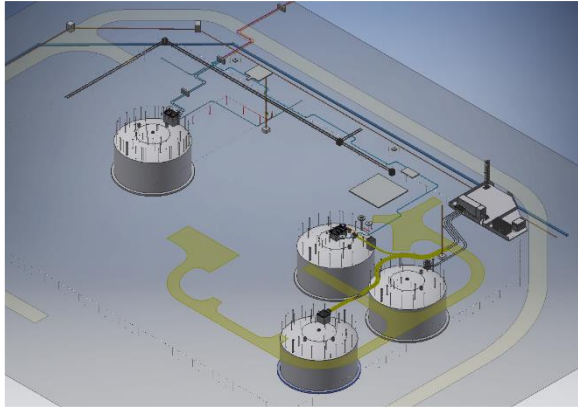



- Completed 30% designs in CY2018
- Completed TSCR system 60%
- Completed WFD 60% design
- On track to initiate TFU 60% design review on March 4, 2019
- On track to initiate TSCR system 90% design review on April 5, 2019

# Project Timeline Expectation

## Tank Side Cesium Removal (TSCR) Demonstration Project and Tank Farm Upgrade (TFU) / Waste Feed Delivery (WFD)

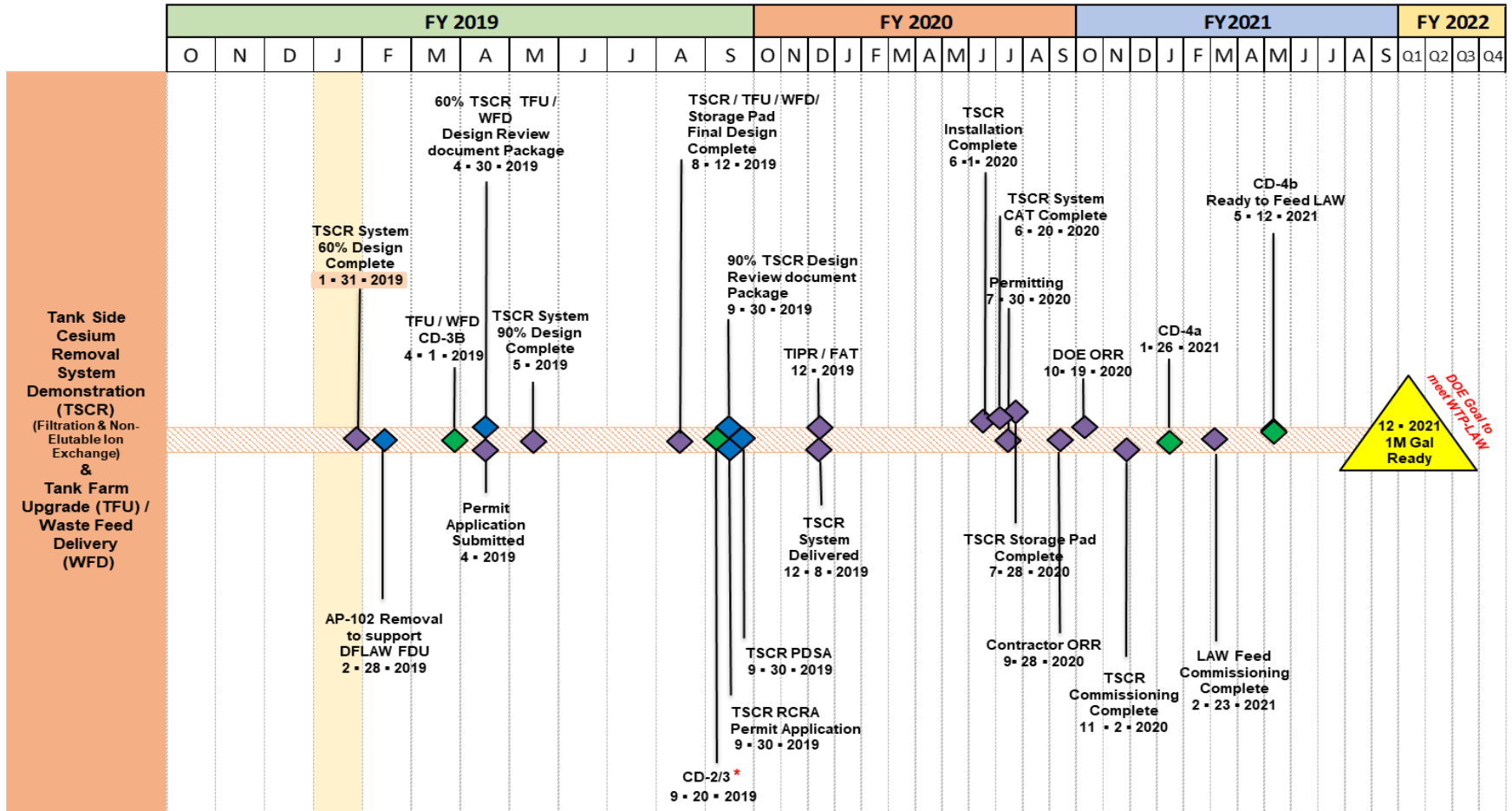

Legend: ◆ Critical Decision Approval ◆ Project Milestones ◆ PEMP FY2019  Complete

\* Includes Waste Transfer Lines & TSCR Infrastructure (Site prep, TSCR pad, utilities, canister storage facility/pad)

FAT= Factory Acceptance Test  
CAT= Construction Acceptance Test  
SAA= Startup Authorization Authority  
TIPR = Technical Independent Project Review

