

0028996

WHC-EP-0661
UC-600

Summary Report on Parametric Pressure Propagation Test TO127-1

H. K. Fauske
Fauske and Associates, Inc.
Burr Ridge, Illinois 60521

Date Published
June 1993



Prepared for the U.S. Department of Energy
Office of Environmental Restoration
and Waste Management



**Westinghouse
Hanford Company**

P.O. Box 1970
Richland, Washington 99352

Hanford Operations and Engineering Contractor for the
U.S. Department of Energy under Contract DE-AC06-87RL10930

Approved for Public Release

LEGAL DISCLAIMER

This report was prepared as an account of work sponsored by an agency of the United States Government. Neither the United States Government nor any agency thereof, nor any of their employees, nor any of their contractors, subcontractors or their employees, makes any warranty, express or implied, or assumes any legal liability or responsibility for the accuracy, completeness, or any third party's use or the results of such use of any information, apparatus, product, or process disclosed, or represents that its use would not infringe privately owned rights. Reference herein to any specific commercial product, process, or service by trade name, trademark, manufacturer, or otherwise, does not necessarily constitute or imply its endorsement, recommendation, or favoring by the United States Government or any agency thereof or its contractors or subcontractors. The views and opinions of authors expressed herein do not necessarily state or reflect those of the United States Government or any agency thereof.

This report has been reproduced from the best available copy. Available in paper copy and microfiche.

Available to the U.S. Department of Energy
and its contractors from
Office of Scientific and Technical Information
P.O. Box 62
Oak Ridge, TN 37831
(615) 576-8401

Available to the public from the U.S. Department of Commerce
National Technical Information Service
5285 Port Royal Road
Springfield, VA 22161
(703) 487-4650

Printed in the United States of America

DISCLM-1.CHP (1-91)

Complete for all Types of Release

Purpose <input type="checkbox"/> Speech or Presentation <input type="checkbox"/> Full Paper (Check only one suffix) <input type="checkbox"/> Summary <input type="checkbox"/> Abstract <input type="checkbox"/> Visual Aid <input type="checkbox"/> Speakers Bureau <input type="checkbox"/> Poster Session <input type="checkbox"/> Videotape		<input type="checkbox"/> Reference <input checked="" type="checkbox"/> Technical Report <input type="checkbox"/> Thesis or Dissertation <input type="checkbox"/> Manual <input type="checkbox"/> Brochure/Flier <input type="checkbox"/> Software/Database <input type="checkbox"/> Controlled Document <input type="checkbox"/> Other	ID Number (include revision, volume, etc.) <u>WHC-SD-WM-TRP-133-REV-0</u> List attachments. <u>WHC-EP-0661</u> Date Release Required <p align="center">April 30, 1993</p>
---	--	---	--

Title <u>Summary Report on Parametric Pressure Propagation Tests T0127-1 and T0128-1 (FAI 93/12 and 93/13)</u>	Unclassified Category <u>UC-</u>	Impact Level <u>3SQ</u>
--	-------------------------------------	----------------------------

New or novel (patentable) subject matter? <input checked="" type="checkbox"/> No <input type="checkbox"/> Yes If "Yes", has disclosure been submitted by WHC or other company? <input type="checkbox"/> No <input type="checkbox"/> Yes (Disclosure No(s).)	Information received from others in confidence, such as proprietary data, trade secrets, and/or inventions? <input checked="" type="checkbox"/> No <input type="checkbox"/> Yes (Identify)
---	---

Copyrights? <input checked="" type="checkbox"/> No <input type="checkbox"/> Yes If "Yes", has written permission been granted? <input type="checkbox"/> No <input type="checkbox"/> Yes (Attach Permission)	Trademarks? <input checked="" type="checkbox"/> No <input type="checkbox"/> Yes (Identify)
---	---

Complete for Speech or Presentation

Title of Conference or Meeting	Group or Society Sponsoring
Date(s) of Conference or Meeting	City/State
Will proceedings be published?	<input type="checkbox"/> Yes <input type="checkbox"/> No
Will material be handed out?	<input type="checkbox"/> Yes <input type="checkbox"/> No

Title of Journal

CHECKLIST FOR SIGNATORIES

Review Required per WHC-CM-3-4	Yes	No	Reviewer - Signature	Indicates Approval	Date
			Name (printed)	Signature	
Classification/Unclassified Controlled Nuclear Information	<input type="checkbox"/>	<input checked="" type="checkbox"/>			
Patent - General Counsel	<input checked="" type="checkbox"/>	<input type="checkbox"/>	S. W. Berglin	<i>[Signature]</i>	4/30/93
Legal - General Counsel	<input checked="" type="checkbox"/>	<input type="checkbox"/>	S. W. Berglin	<i>[Signature]</i>	
Applied Technology/Export Controlled Information or International Program	<input type="checkbox"/>	<input checked="" type="checkbox"/>			
WHC Program/Project	<input checked="" type="checkbox"/>	<input type="checkbox"/>	R. J. Cash	<i>[Signature]</i>	4-29-93
Communications	<input checked="" type="checkbox"/>	<input type="checkbox"/>	W. P. Whiting	<i>[Signature]</i>	4-30-93
RI Program/Project	<input checked="" type="checkbox"/>	<input type="checkbox"/>	R. F. Christensen	<i>[Signature]</i>	4/30/93
Publication Services	<input checked="" type="checkbox"/>	<input type="checkbox"/>	C. J. Forbes	<i>[Signature]</i>	6/28/93
Other Program/Project	<input type="checkbox"/>	<input checked="" type="checkbox"/>			

Information conforms to all applicable requirements. The above information is certified to be correct.

References Available to Intended Audience	<input checked="" type="checkbox"/> Yes <input type="checkbox"/> No
Transmit to DOE-HQ/Office of Scientific and Technical Information	<input checked="" type="checkbox"/> Yes <input checked="" type="checkbox"/> No
Author/Requestor (Printed/Signature)	Date
R. J. Cash <i>[Signature]</i>	4/29/93
Intended Audience	
<input type="checkbox"/> Internal <input type="checkbox"/> Sponsor <input checked="" type="checkbox"/> External	
Responsible Manager (Printed/Signature)	Date
J. C. Fulton <i>[Signature]</i>	4/30/93

INFORMATION RELEASE ADMINISTRATION APPROVAL STAMP	
Stamp is required before release. Release is contingent upon resolution of mandatory comments.	
	
Date Cancelled	Date Disapproved

TABLE OF CONTENTS

	<u>Page</u>
1.0 INTRODUCTION AND SUMMARY	1-1
2.0 TEST EQUIPMENT	2-1
2.1 Test Equipment	2-1
3.0 TEST MATERIALS	3-1
3.1 Ferrocyanide Sample	3-1
3.2 Oxidation Reaction	3-1
3.3 Reaction Ignition Source	3-2
4.0 TEST PROCEDURES	4-1
4.1 Test Protocol	4-1
4.2 Gravimetric Analysis	4-1
4.3 Filtered Venting	4-2
4.4 Test Execution	4-2
5.0 TEST RESULTS	5-1
5.1 Propagation Rate Data	5-1
5.2 Overall Containment Environment Response	5-1
5.3 Aerosol Sample Collection	5-10
5.4 Overall Material Balance	5-10
6.0 REFERENCES	6-1
APPENDIX A: Letter from R. J. Cash to H. K. Fauske (Ref. [1])	A-1
APPENDIX B: Microbalance Calibration	B-1
APPENDIX C: Test Data Sheets for Tests T0208-1 and T0209-1	C-1

LIST OF TABLES

<u>Table No.</u>		<u>Page</u>
1-1	Summary of Aerosol Test Data	1-1
5-1	Reaction Speed Data for Test T0208-1 (60°C)	5-4
5-2	Reaction Speed Data for Test T0209-1 (120°C)	5-4
5-3	Comparison of Related Propagation Rate Tests	5-5
5-4	Overall Mass Balance	5-11

LIST OF FIGURES

<u>Figure No.</u>		<u>Page</u>
2-1	Overall test equipment configuration with 49 L containment vessel and 25 mm dia. sample holder with aerosol filter and orifice unit	2-2
2-2	40 liter containment vessel	2-3
2-3	25 mm diameter sample holder used in burn velocity tests. Sample inventory \approx 45 to 50 gm	2-4
2-4	Schematic illustration of aerosol filter holder	2-6
5-1	Thermocouple response to reaction propagation for test T0208-1, 3 atm abs., 60°C, 25 mm sample holder diameter, 1 wgt.% H ₂ O InFarm-1 bottom sample. Average propagation velocity 12.6 cm/min	5-2
5-2	Thermocouple response to reaction propagation for test T0209-1, 3 atm abs., 120°C, 25 mm holder diameter, 1 wgt.% H ₂ O InFarm-1 bottom sample. Average propagation velocity 20.4 cm/min	5-3
5-3	Containment response to test T0209-1 (short time)	5-6
5-4	Containment response to test T0208-1 (long time scale)	5-7
5-5	Containment response to test T0209-1 (short time)	5-8
5-6	Containment response to test T0209-1 (long time scale)	5-9

1.0 INTRODUCTION AND SUMMARY

This report presents the results of two ferrocyanide propagating reaction generated aerosol tests, conducted as a part of a series of tests directed by Westinghouse Hanford Company (WHC) in Ref. [1]. For the record, Ref. [1] is included as Appendix A. The tests discussed in this document are designated as T0208-1 and T0209-1. The tests were carried out in a 49 L containment volume equipped with an aerosol filter housing. The test setup is described in Section 2.0. Each test used an \approx 50 gm. sample of InFarm-1 bottom flow sheet material which was vacuum dried, screened through a 140 mesh sieve, and rehydrated to 1 wgt. % water content prior to testing. The test sample and reaction ignition method are described in Section 3.0. A special test protocol was defined and followed for the tests as described in Section 4.0 and Appendix B.

Test results discussed in Section 5.0 are summarized in Table 1-1. Both tests yielded a significant aerosol sample on the filter element. These filter elements and aerosol deposits have been sent to WHC for analysis, and any information as to the content or chemical composition of the trapped particulate material awaits the results of WHC efforts in this regard. The reaction propagation tests were conducted at 60°C and 120°C respectively. The average propagation velocities noted in Table 1-1 are consistent with other related observations.

Table 1-1
Summary of Aerosol Test Data

Test	T0208-1	T0209-1
Nominal Temperature	60°C	120°C
Reaction Propagation Velocity	12.6 cm/min	20.4 cm/min
Aerosol Particulate Collected	366.15 mg	595.7 mg

2.0 TEST EQUIPMENT

2.1 Test Equipment

The overall test equipment configuration is shown in Fig. 2-1. This configuration is similar to that illustrated in Ref. [1], but features a 49 L containment vessel. The containment vessel and environment thermocouple locations are shown in Fig. 2-2. The flow limiting orifice attached to the downstream exit from the aerosol filter unit is sized to limit the maximum flow through the filter unit to 0.5 scfm at 30 psig test pressure.

Pre-test calculations and calibrations with argon gas indicated that a downstream flow restriction consisting of a 6.4 inch long small bare tube (id = 0.425 inch) would give the required flow rate at 30 psig. This would nominally lead to a post-test depressurization and aerosol collection time of approximately 20 min.

The aerosol source will be derived from a standard burn of (1 wt. % water) InFarm-1 bottom sample in a 25 mm diameter sample holder.

Fig. 2-3 shows details of the 25 mm diameter sample holder which will be used for the aerosol test activities. A 0.002 inch thick, 316 stainless steel sheet is rolled onto a 25 mm diameter mold, spot welded to hold a round tube configuration and trimmed to 4 inches length. This tube (considered to be disposable) is slipped over the base stand. A sample tube heater and base stand heater are installed as shown in the figure. Type K thermocouples, 0.020 inch diameter sheath are located at axial elevations shown in Fig. 2-3. Note the bottom thermocouple, No. 4, is inserted through the base plate. All other thermocouples make side penetrations through the sample holder between the heater coil wraps and all are positioned at the center of the tube. Also note that TC #4 will be used to indicate the completion of a test burn and signal the time for opening the aerosol filter vent. A split signal from TC #4 will be directed to a chart recorder so as to provide a visual indication of the event (see Fig. 2-1).

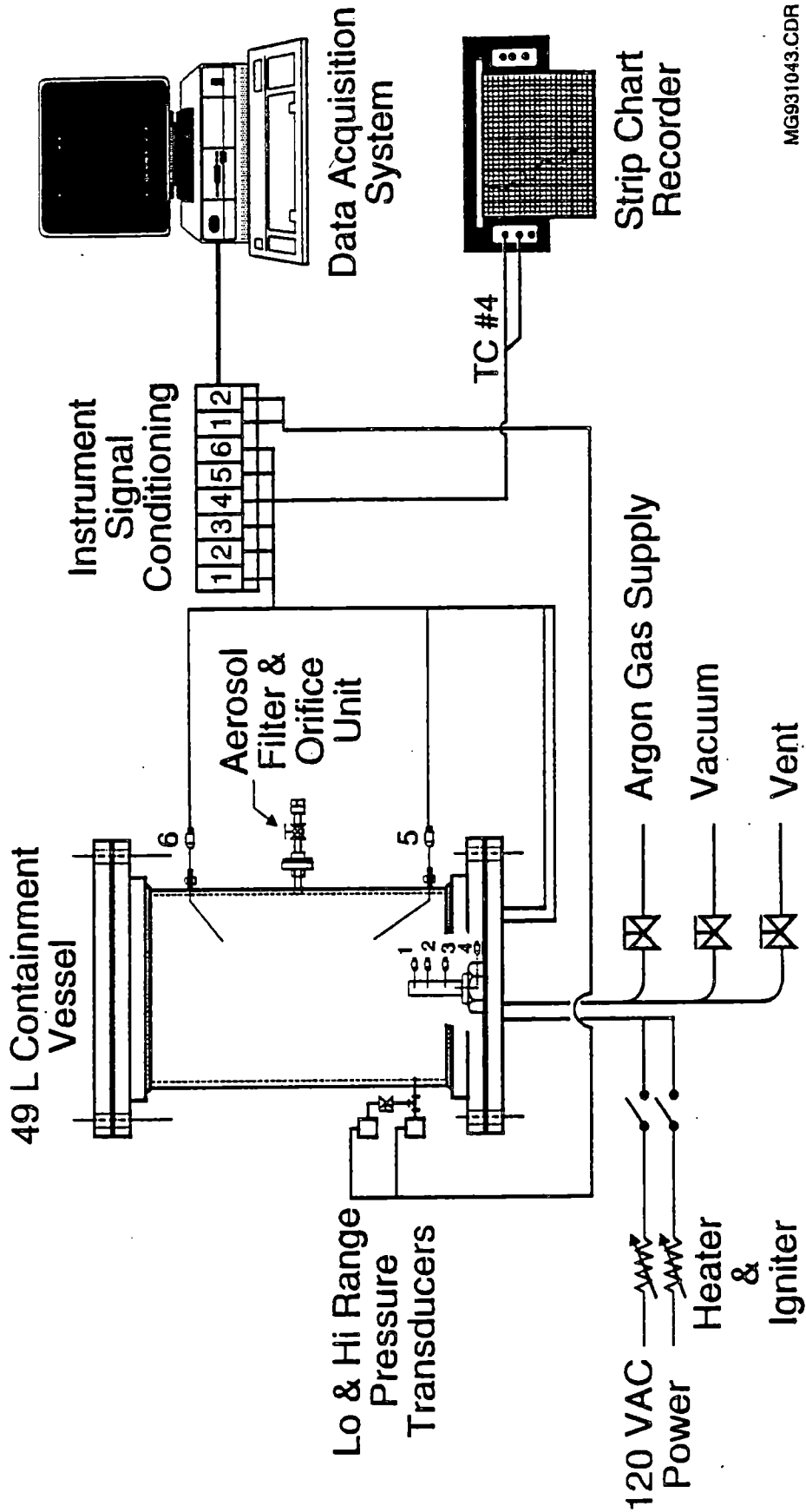

MG931043.CDR

Fig. 2-1 Overall test equipment configuration with 49L containment vessel and 25 mm dia. sample holder with aerosol filter and orifice unit.

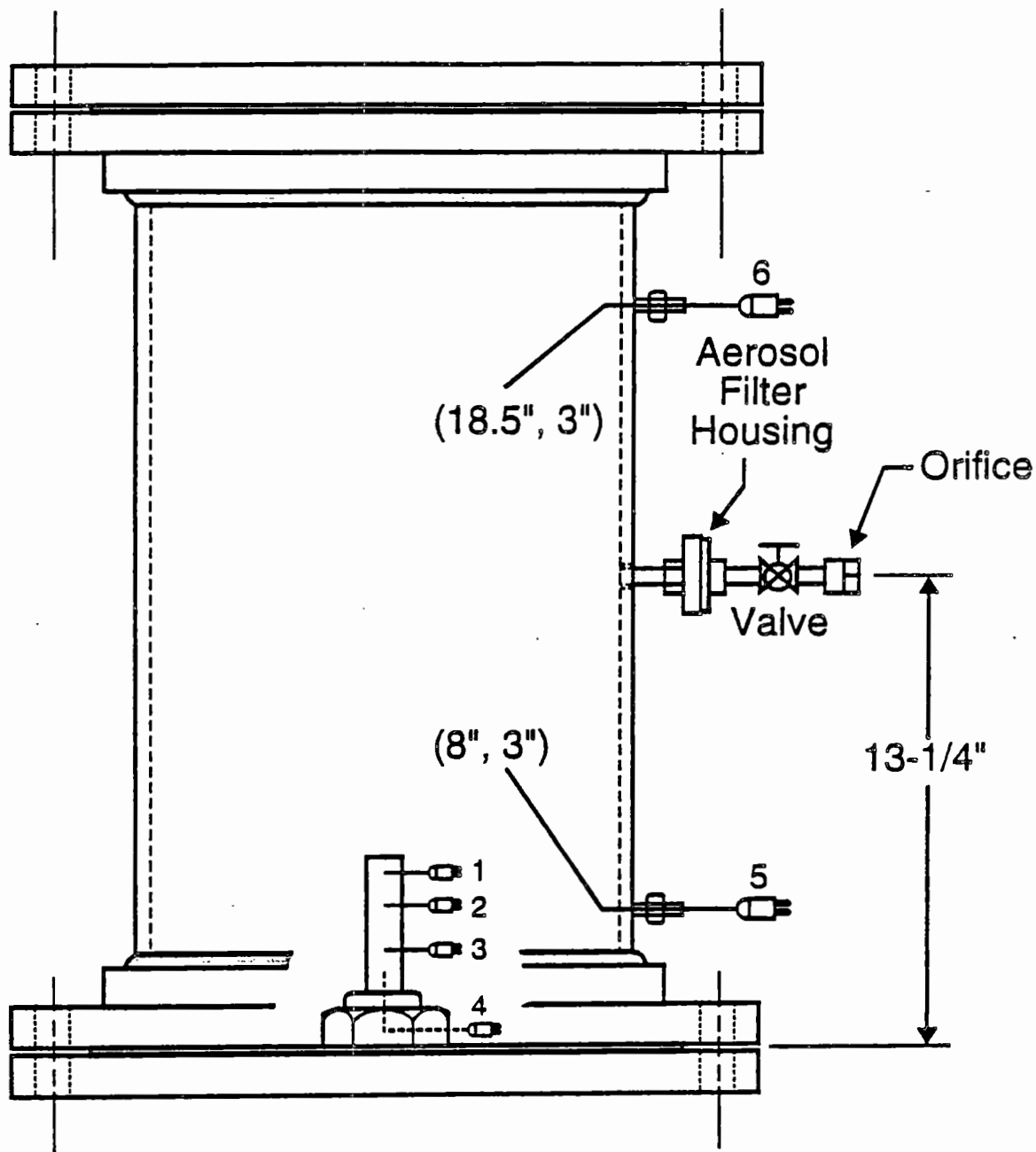

MG931041.CDR

Fig. 2-2 40 liter containment vessel.

12" ID x 0.375" wall x 26 1/2" long with 150 lb. flanged ends as shown with 1" dia. x 4" long sample holder shown to scale. (y,r) indicates TC location relative to bottom (y) and away from wall (r).

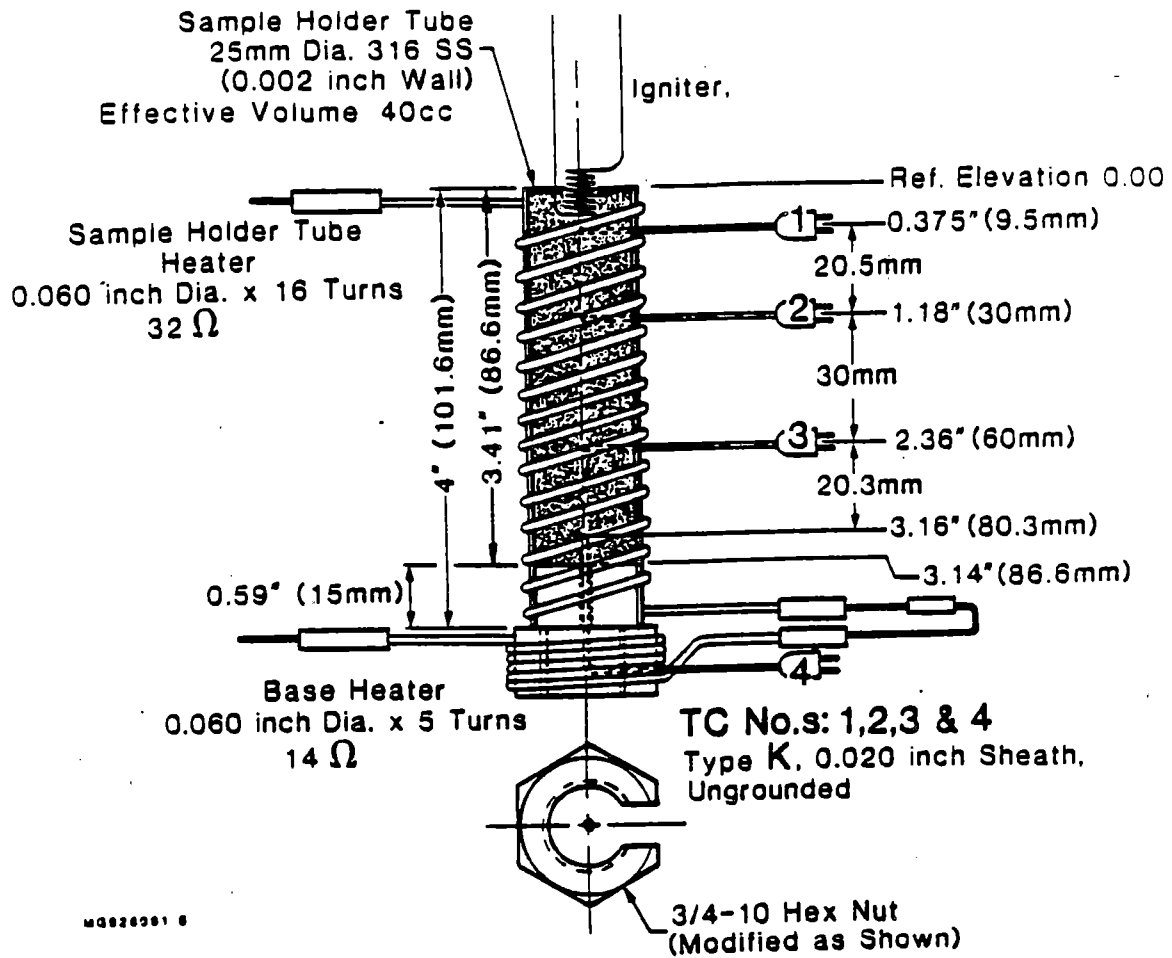

40828091 8

Fig. 2-3 25 mm diameter sample holder used in burn velocity tests. Sample inventory ≈ 45 to 50 gm.

Since material balance considerations will be emphasized in the aerosol test, the following dry weights of the sample holder elements are noted:

25 mm Sample Holder Base	152.6 gm
25 mm Sample Holder Tube	3.5 gm
Heater Elements (Two)	52.1 gm
Thermocouples (Four)	<u>23.7 gm</u>
TOTAL	231.9 gm

Finally, a schematic of the aerosol filter housing is shown in Fig. 2-4. Filter elements were handled by tweezers only so as to avoid contact with human hands.

Filter Holder Assembly

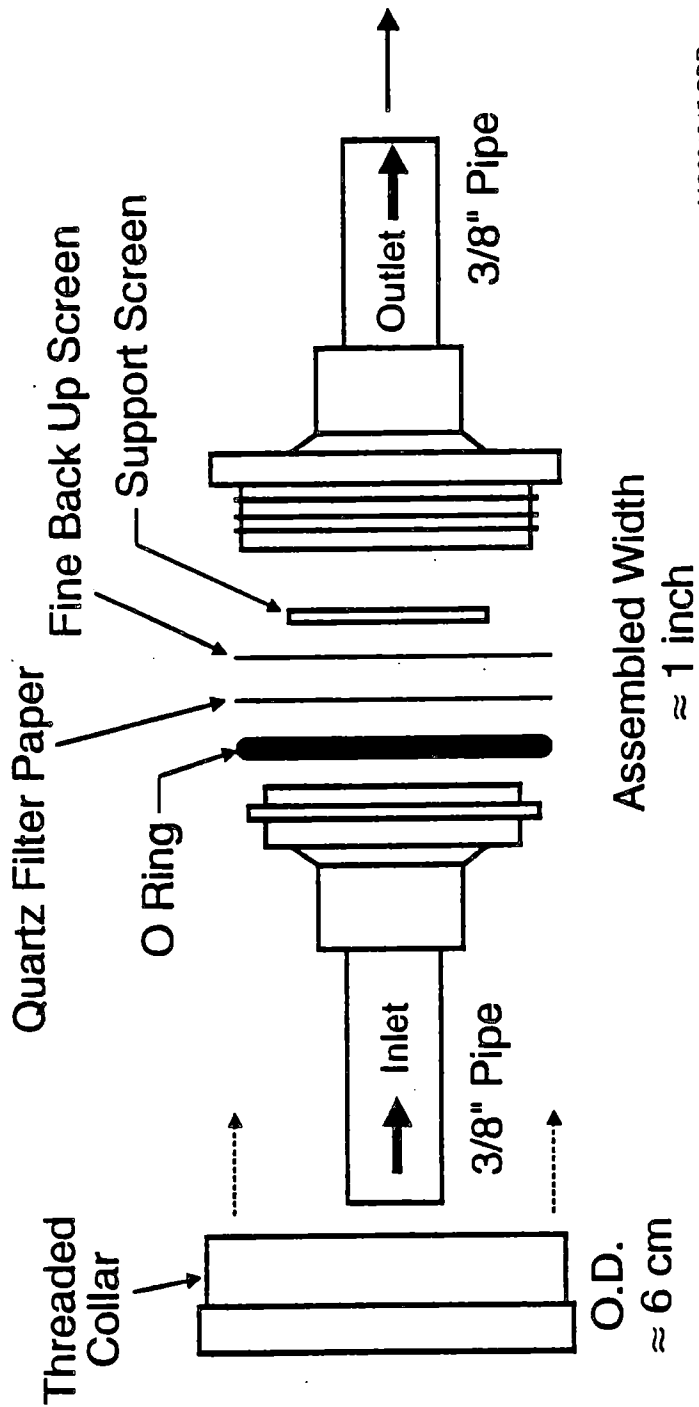

MG931045.CDR

Fig. 2-4 Schematic illustration of aerosol filter holder.

3.0 TEST MATERIALS

3.1 Ferrocyanide Sample

The test materials will be the WHC prepared samples of InFarm-1 bottom disodium mononickel ferrocyanide ($\text{Na}_2\text{NiFe}(\text{CN})_6$). These samples contain a trace amount of $\text{C}_s\text{NiFe}(\text{CN})_6$ ($\approx .1 \text{ gm C}_s$ in a 50 gm sample per WHC estimate). The sample was vacuum dried and sieved at 140 mesh. The sample was re-hydrated to 1 wt.% water prior to testing.

3.2 Oxidation Reaction

The fuel/oxidizer assay for the samples is as yet not known, but will be supplied by Westinghouse Hanford Company. One estimate of a balanced stoichiometric reaction is given below.

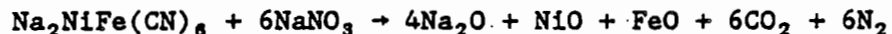

Assuming CO_2 and N_2 are the only permanent gaseous species produced, the above stoichiometric balance indicates 12 moles of gas to be liberated per mole of $\text{Na}_2\text{NiFe}(\text{CN})_6$. The formula weight of $\text{Na}_2\text{NiFe}(\text{CN})_6$ is 316.66 gm/gm mole. Therefore, a 25 mm sample holder containing 50 gm of dried sample at 0.26 wgt. fraction ferrocyanide will contain $(.26 \times 50)/316.66 = 0.041$ mole of $\text{Na}_2\text{NiFe}(\text{CN})_6$ and can theoretically produce $.041 \times 12 = 0.492$ mole gas.

Other test estimates indicate the gas production to lie in the range of 12 to 13 moles of gas per mole of ferrocyanide burned. Assuming an average molecular wgt. of the gas produced as 36 gm/gmol one can further estimate that a 50 gm test sample will yield between 17.7 gm and 19.2 gm of gas or that the solid reaction product residue should be between 30.8 gm and 32.3 gm.

3.3 Reaction Ignition Source

The use of a barium peroxide and aluminum mixture has proven to be an effective starter for the ferrocyanide reaction. This starter mixture can be ignited with a hot wire. The stoichiometric reaction is written as

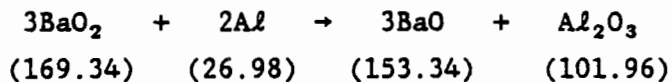

Numbers in () under the above reaction represent the formula weights of the reactants and products. Thermochemical evaluation of this stoichiometric relation indicate the liberation of heat of reaction estimated to be -338 kcal/g-mole BaO_2 or ≈ 9.5 mJ/kg BaO_2 . The estimated reaction temperature increase is of the order of 2000°C . This reaction is used to initiate the thermite reactions ($\text{Fe}_2\text{O}_3 + 2\text{Al} \rightarrow \text{Al}_2\text{O}_3 + 2\text{Fe}$). The barium peroxide-aluminum reaction as written does not appear to be gassy. Barium oxide, mp 2000°C , bp 3100°C , appears to be quite stable (Al_2O_3 has a boiling point of 2900°C). However, BaO_2 is reported to decompose to Ba and O_2 at 800°C . This could be a source of gas, albeit small, for this ignition method. The barium peroxide/Al starting mixture will be separated from the ferrocyanide column by a thin aluminum foil. The ignition method has been shown to be effective in previous propagation rate studies, Ref. [2].

4.0 TEST PROCEDURES

4.1 Test Protocol

The objective of the designated aerosol tests is to provide WHC with a quantitative measure of the possible release of aerosolized cesium following an open burn of cesium-nickel ferrocyanide. WHC estimates that a 50 gm test sample will contain ≈ 0.1 gm of cesium in the form of $\text{CsNiFe}(\text{CN})_6$.

Two aerosol tests have been defined by WHC. The base test parameters are:

- | | |
|---|--|
| (a) Sample holder | -- 25 mm dia. |
| (b) Sample charge | -- ≈ 50 gm @ 1.2 sg. |
| (c) Particle size | -- Screened through 140 mesh sieve |
| (d) Moisture content | -- 1 wt% ($\approx .5$ gm) |
| (e) Sample temperature prior
to ignition | -- 60°C for Test No. 1 (T0208-1)
120°C for Test No. 2 (T0209-1) |
| (f) Containment volume atmosphere | -- Argon |
| (g) Containment volume pressure | -- 3 atm abs. (28 to 30 psig) |

4.2 Gravimetric Analysis

WHC has requested a complete material balance on the test reactants and products. In order to facilitate this, the inside walls of the 49 L vessel was lined with aluminum foil all foil elements in addition to the reaction sample holder will be weighed before and after testing so as to account for the disposition of the unreacted sample charge.

In addition to the overall mass balance, a special scale has been procured so as to record the pre- and post-test weight of the filter paper and O-ring to four significant figures. A calibration record for the scale is included as Appendix B.

4.3 Filtered Venting

The post reaction venting of the containment atmosphere was initiated on completion of the reaction. This was signaled by the response of the lowest level thermocouple which was made visible by a recording on a strip chart recorder, (see Fig. 2-1). The flow control orifice was tested so as to achieve a venting rate of ≈ 0.5 cfm at 30 psig.

4.4 Test Execution

The following procedure steps were followed in the execution of the aerosol tests. Completed test data sheets are included as Appendix C.

Sample Preparation

Preliminary: Test ID # _____ Date _____

Step	Activity	Record or Check
1.	Measure 50 gm of vacuum dried and sieved In-Farm-1 bottom sample into clean glass beaker.	_____ <input type="checkbox"/>
	Glass beaker tare weight	_____
2.	Add .5 gm distilled and demineralized water. Mix thoroughly.	_____ <input type="checkbox"/>
3.	Record total weight of container and sample.	_____ <input type="checkbox"/>
4a.	Record weight of empty sample holder.	_____
4b.	Add sample to sample holder packing with clean glass rod.	_____ <input type="checkbox"/>

Step	Activity	Record or Check
5.	After loading is complete (Step 4) record:	
	Weight of source beaker and residue.	_____
	Weight of loaded test sample holder.	_____
	Depth of charge in sample holder.	_____
6.	Finish sample holder assembly and dressing -	
	<ul style="list-style-type: none"> • heaters • thermocouples • insulation 	
	Record assembled weight.	_____
7.	Prepare a two to four gram charge of barium peroxide/aluminum starter mix in an 25 mm dia. aluminum foil cup and record total weight.	_____
	Hold for adding to test sample later (step 11).	<input type="checkbox"/>
<u>Filter Preparation</u>		
8a.	Weigh clean unused filter element.	_____
8b.	Install in filter housing per Fig. 2-4 taking care to use only tweezers.	<input type="checkbox"/>
<u>Containment Vessel Preparation</u>		
9.	Containment vessel fittings and seals have been previously checked for leak-tightness.	<input type="checkbox"/>
10.	Containment vessel is open and cleaned of all prior test residue.	<input type="checkbox"/>

Step	Activity	Record or Check
11.	Line all inside surfaces of containment vessel with aluminum foil and record weight of foil used.	_____
12a.	Install assembled test sample holder on bottom flange of containment vessel and secure all internal connections.	<input type="checkbox"/>
12b.	Install igniter mix and igniter.	<input type="checkbox"/>
12c.	Take photograph of sample holder.	<input type="checkbox"/>
	Pre-Test (mg)	Post-Test (mg)
	Filter element _____	_____
	O-Ring _____	_____
	Filter Element + O-Ring _____	_____
13.	Seal containment vessel and purge five times between full vacuum and 0 psig with Argon gas.	
	<u>Cycle</u>	<u>Vacuum</u>
		<u>Fill</u>
	1	_____
	2	_____
	3	_____
	4	_____
		Test Pressure
	5	_____
	At end of 5th cycle Argon pressure should be set to test pressure.	
	Record pressure.	_____
14.	Hold test pressure during instrument checkout.	<input type="checkbox"/>

Step	Activity	Record or Check												
15.	Set up instruments and check proper alignment.	<input type="checkbox"/>												
	Check proper calibration setup.	<input type="checkbox"/>												
	Notes _____ _____ _____ _____													
16.	Verify containment is holding pressure.	<input type="checkbox"/>												
	<u>Test Sequence</u>													
17.	Verify heater circuit continuity.	<input type="checkbox"/>												
18.	Verify igniter circuit continuity.	<input type="checkbox"/>												
19.	Begin heating sample up to test temperature. When TC #3 is at test temperature, record temperatures.													
	<table> <tr> <td>TC #1</td> <td>_____ °C</td> <td>_____ °C</td> </tr> <tr> <td>TC #2</td> <td>_____ °C</td> <td>_____ °C</td> </tr> <tr> <td>TC #3</td> <td>_____ °C</td> <td>_____ °C</td> </tr> <tr> <td>TC #4</td> <td>_____ °C</td> <td>_____ °C</td> </tr> </table>	TC #1	_____ °C	_____ °C	TC #2	_____ °C	_____ °C	TC #3	_____ °C	_____ °C	TC #4	_____ °C	_____ °C	
TC #1	_____ °C	_____ °C												
TC #2	_____ °C	_____ °C												
TC #3	_____ °C	_____ °C												
TC #4	_____ °C	_____ °C												
20.	Verify TC #4 is being recorded on strip chart recorder.	<input type="checkbox"/>												
21.	Verify data acquisition system is ready.	<input type="checkbox"/>												
22.	Verify igniter system is ready.	<input type="checkbox"/>												
23.	Start data acquisition system and on operator signal close igniter circuit.	<input type="checkbox"/>												
24.	On response of TC #4 to burn open filter vent.	<input type="checkbox"/>												

Step	Activity	Record or Check
25.	When containment pressure has fallen to 0 psig close filter vent.	<input type="checkbox"/>
26.	Stop data taking.	<input type="checkbox"/>
<u>Post-Test Activities</u>		
27a.	Weigh filter paper and O-Ring and quickly....	_____
27b.	Insert in filter paper holder for shipment and label with test ID #.	_____ <input type="checkbox"/>
28.	Open containment vessel and take photographs.	_____
29a.	Weigh test sample holder.	_____
29b.	Weigh loose solid metal.	_____
29c.	Weigh all foil material.	_____
29d.	Total weight of material in containment vessel.	_____
30.	Reduce test data.	<input type="checkbox"/>
31.	Clean test apparatus and prepare for follow-on test.	<input type="checkbox"/>

5.0 TEST RESULTS

5.1 Propagation Rate Data

The thermocouple data which indicate the linear reaction velocity are shown in Figs. 5-1 and 5-2 for tests T0208-1 and T0209-1 respectively. Tables 5-1 and 5-2 indicate the respective reduced speed measurements which can be obtained from these data.

The representative average velocity for these tests can be summarized as

<u>Test</u>	<u>Temperature</u>	<u>Reaction Velocity</u>
T0208-1	60°C nom.	2.1 mm/sec (12.6 cm/min)
T0209-1	120°C nom.	3.4 mm/sec (20.4 cm/min)

For comparison, the average reaction velocity observed in comparable dry InFarm bottom ferrocyanide tests is shown in Table 5-3. All observed reaction velocities appear to be consistent for the test material. Note that the response of TC1 in both tests was somewhat erratic and was discounted in T0209-1 as a reliable reaction speed indicator. This behavior is often caused by the igniter but the severe difficulty in T0209-1 appears to be a random fault.

5.2 Overall Containment Environment Response

Figs. 5-3, 5-4, 5-5, and 5-6 show the containment environment response on short and long time scales. The start of the filtered venting process is indicated for each test to occur at peak pressure. This was concurrent with the completion of the reaction as indicated by the lowest thermocouple TC4. The containment environment pressure response appears to be derived from two sources. An initial rapid pressure increase of ≈ 10 psig is due to the igniter and because of the corresponding concurrent rapid response of the

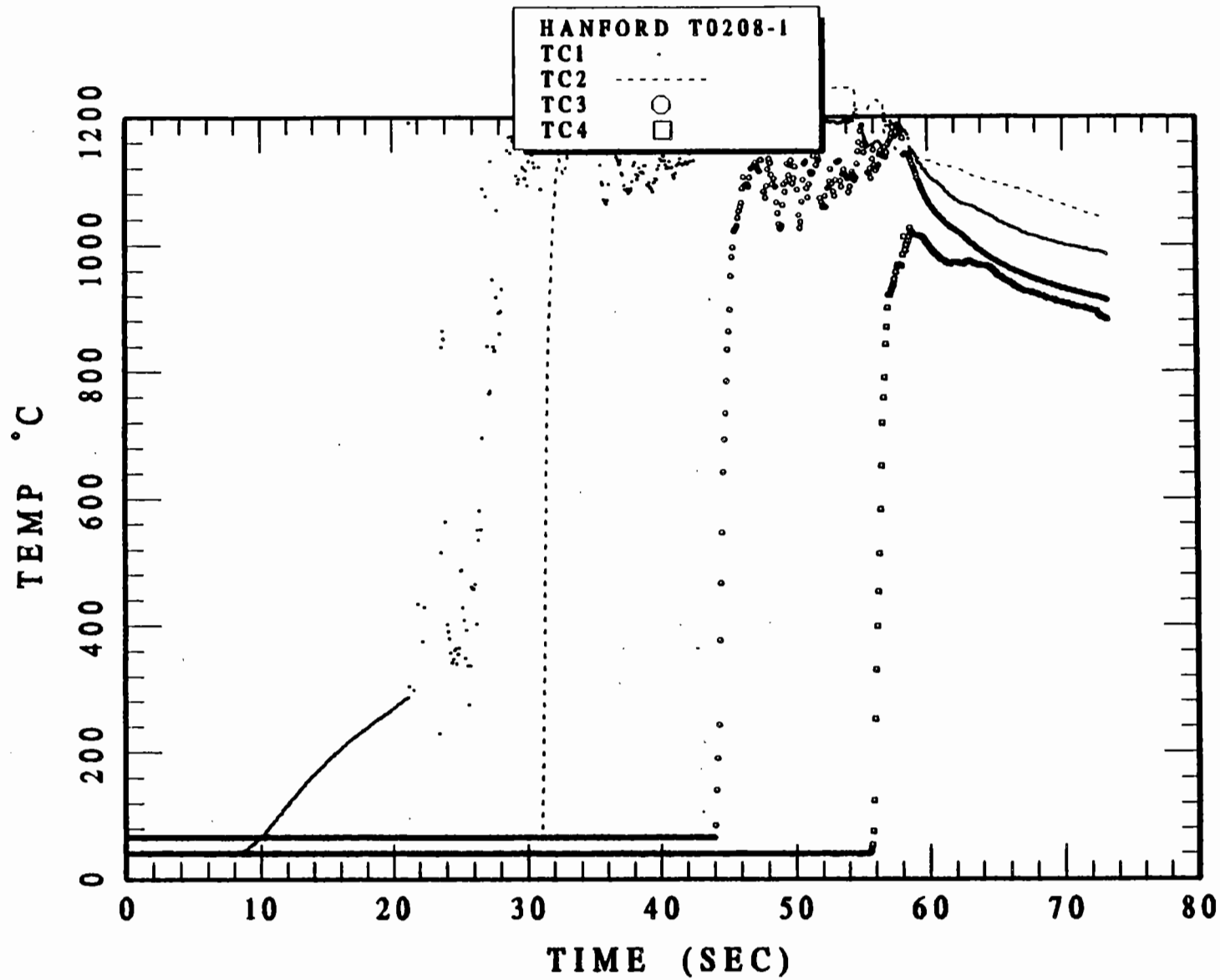

TIME VS TC1, TC2, TC3, TC4

Fig. 5-1 Thermocouple response to reaction propagation for test T0208-1, 3 atm abs., 60°C, 25 mm sample holder diameter, 1 wt.% H₂O InFarm-1 bottom sample. Average propagation velocity 12.6 cm/min.

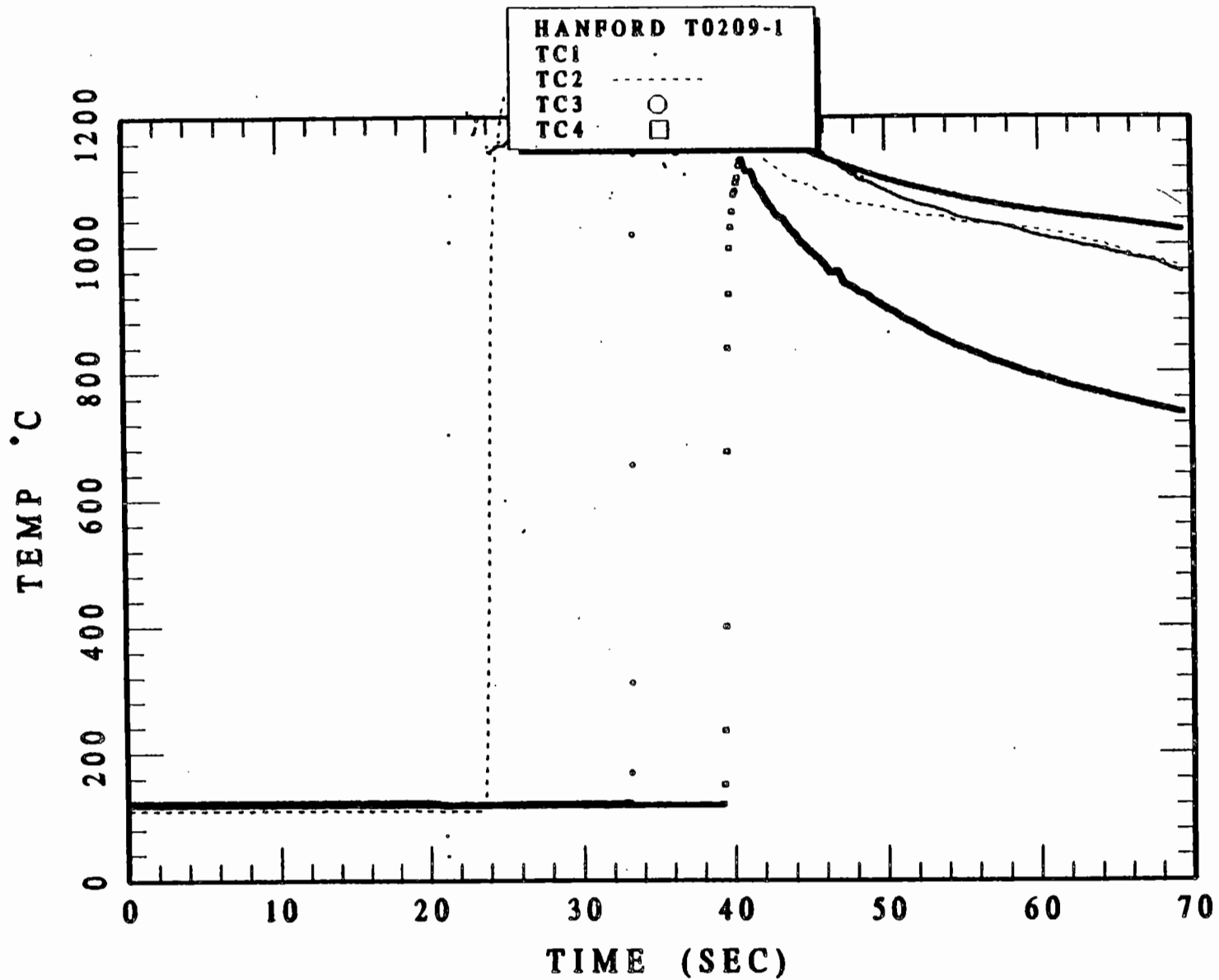

TIME VS TC1, TC2, TC3, TC4

Fig. 5-2 Thermocouple response to reaction propagation for test T0209-1, 3 atm abs., 120°C, 25 mm sample holder diameter, 1 wt.% H₂O InFarm-1 bottom sample. Average propagation velocity 20.4 cm/min.

Table 5-1
Reaction Speed Data for Test T0208-1 (60°C)

TC#	Location* mm	Time sec	Reaction Propagation Rate
TC1	9.53	21.25	TC1 → TC2 2.10 mm/sec
TC2	30.16	31.09	TC2 → TC3 2.26 mm/sec
TC3	59.53	44.09	TC3 → TC4 1.84 mm/sec
TC4	81.06	55.78	TC1 → TC4 2.07 mm/sec

*From top of sample holder.

Table 5-2
Reaction Speed Data for Test T0209-1 (120°C)

TC#	Location* mm	Time sec	Reaction Propagation Rate
TC1	9.53	20.98	TC1 → TC2 7.58 mm/sec
TC2	30.16	23.70	TC2 → TC3 3.16 mm/sec
TC3	59.93	33.11	TC3 → TC4 3.82 mm/sec
TC4	83.44	39.27	TC1 → TC4 3.42 mm/sec

*Result discounted due to faulty TC1.

Table 5-3
Comparison of Related Propagation Rate Tests

Test	Material	Pressure atm	Initial Temperature °C	Specific Gravity	Reaction Propagation Rate cm/min
T0727-1	IF1B	1	26	1.23	10
*T0127-1	IF1B	10	60	1.26	16
T0819-1	VWV	50	60	1.25	132
**T0128-1	IF1B	53	60	1.33	32

*Ref. [4]

**Subject of this report.

IF1B - In-Farm 1 bottom flow sheet material.

VWV - Vendor supplied material.

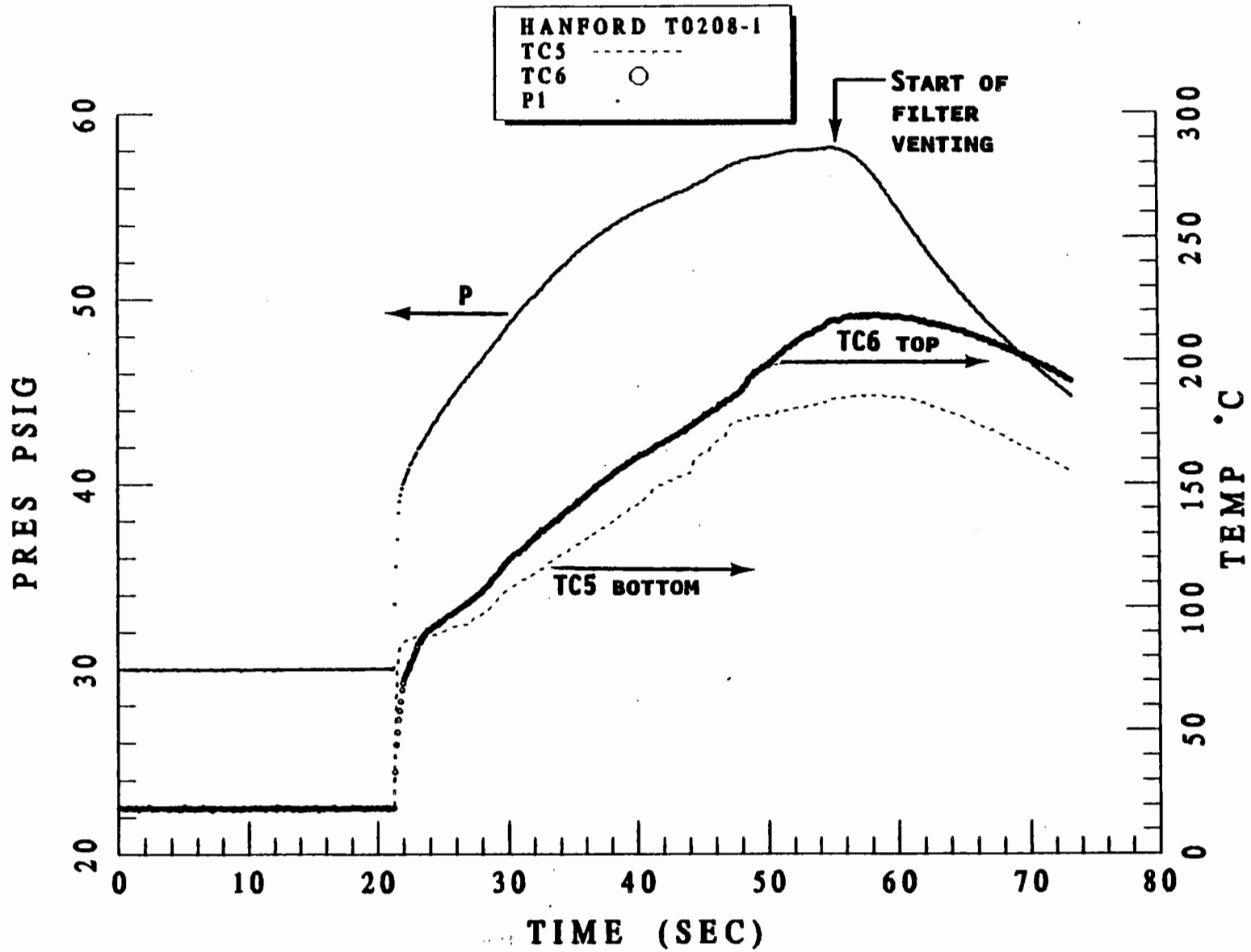

TIME VS. P, TC5, TC6

Fig. 5-3 Containment response to test T0209-1 (short time).

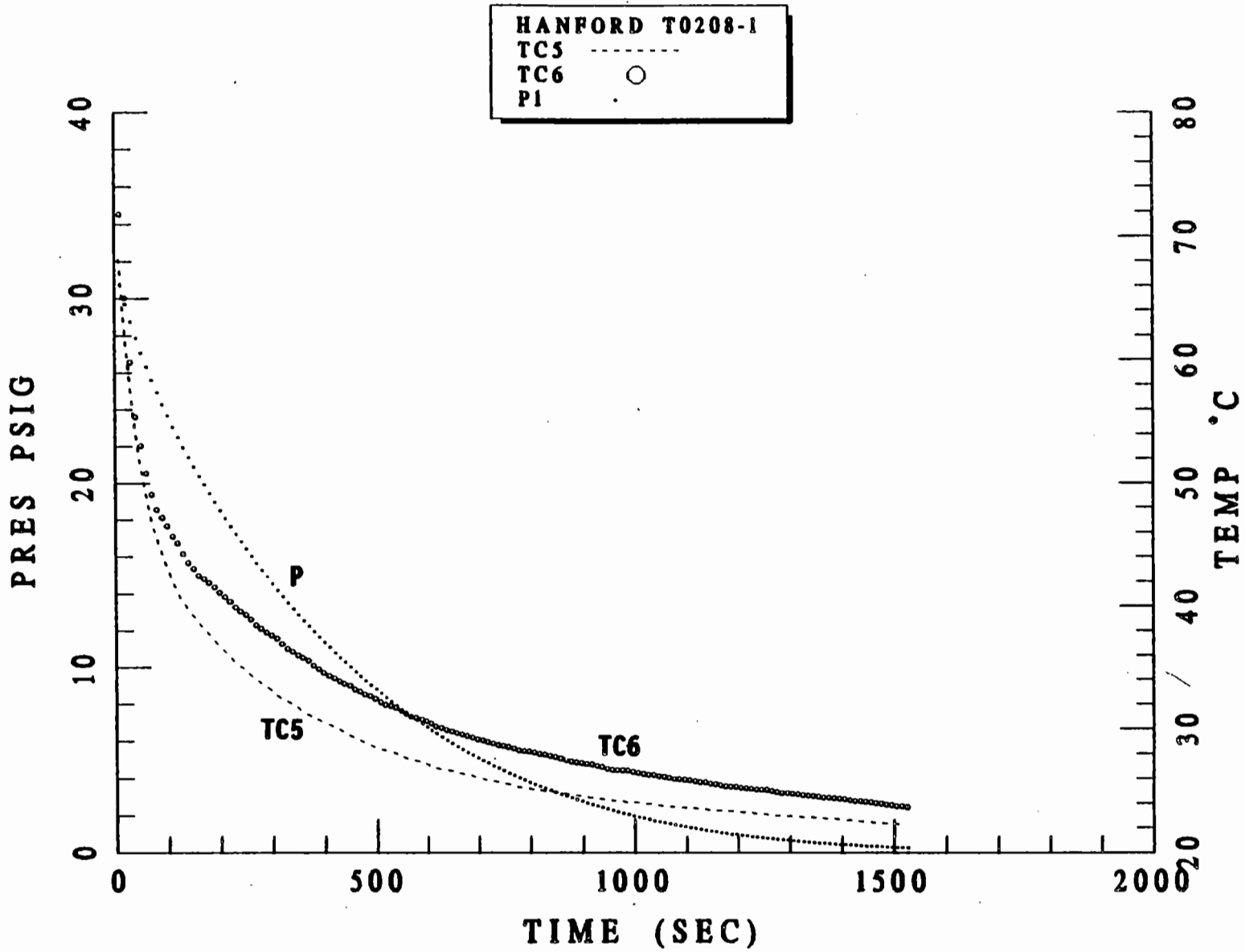

TIME VS. P, TC5, TC6

Fig. 5-4 Containment response to test T0208-1 (long time scale). Note 0 time on this figure corresponds to 118.8 sec. on short time scale of Fig. 5-3.

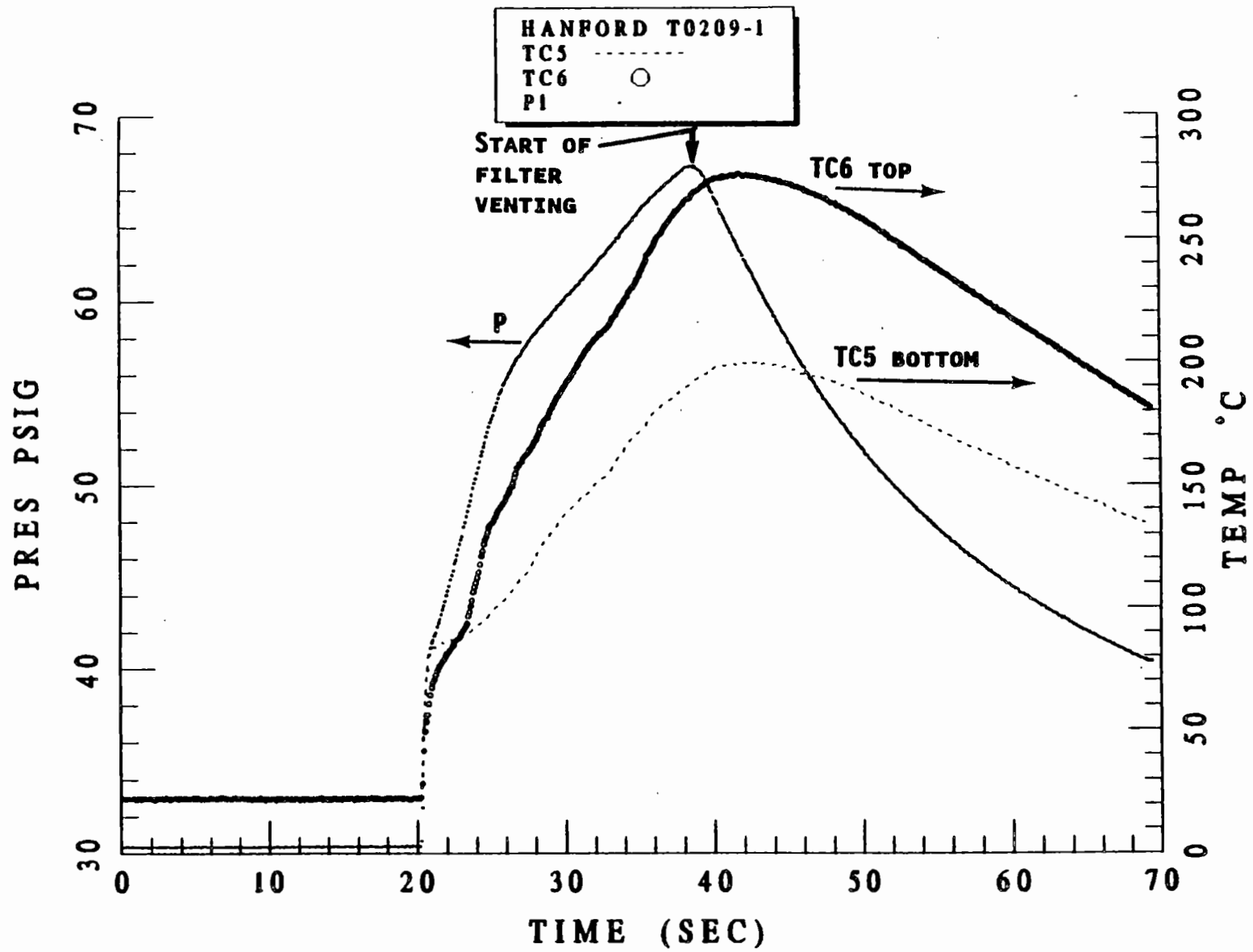

TIME VS. P, TC5, TC6

Fig. 5-5 Containment response to test T0209-1 (short time).

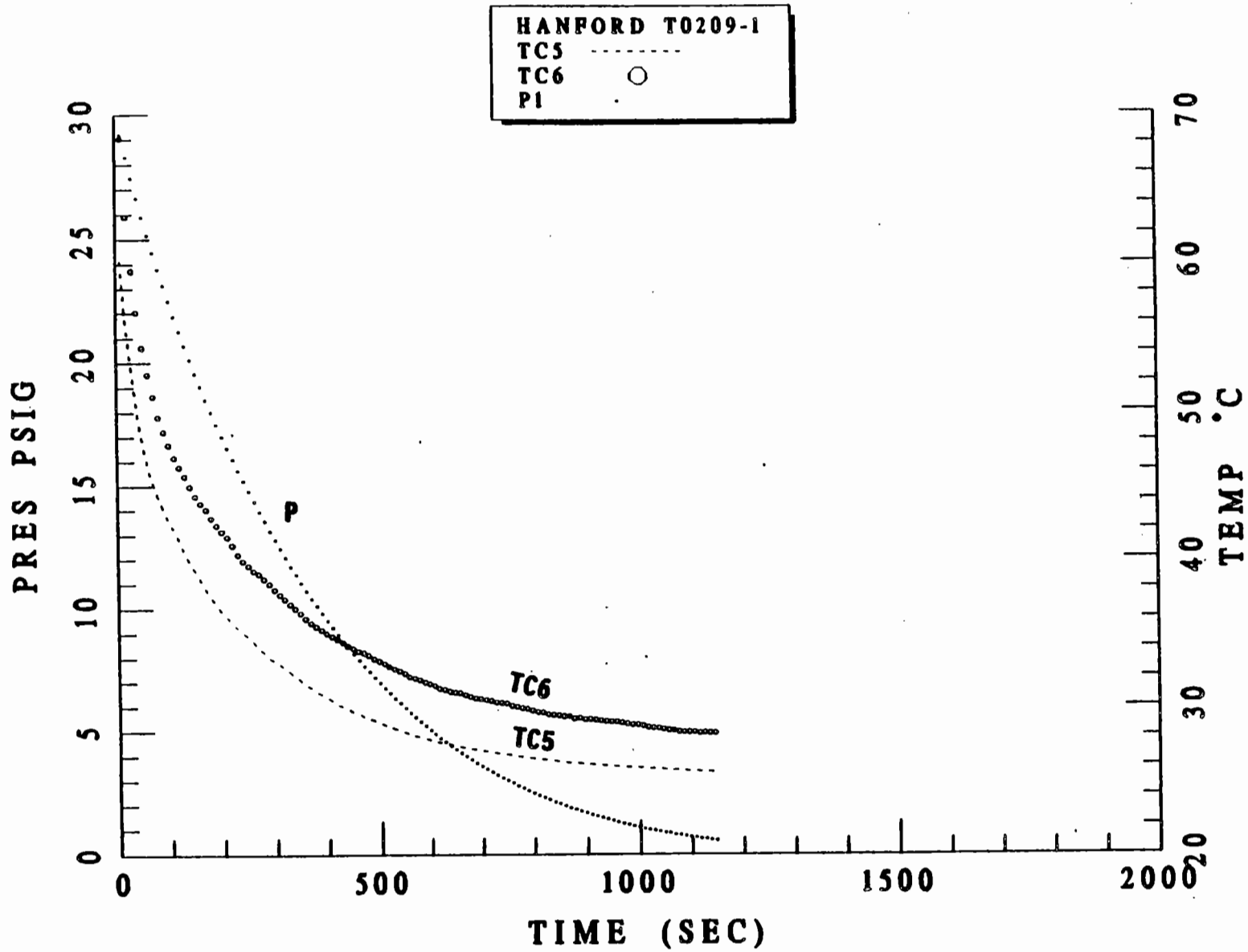

TIME VS. P, TC5, TC6

Fig. 5-6 Containment response to test T0209-1 (long time scale). Note 0 time on this figure corresponds to 122.8 sec on short time scale of Fig. 5-5.

two environment thermocouples, it is concluded that this is predominantly a thermal effect. The second stage pressure increase of ≈ 15 psig in test T0208-1 and ≈ 25 psig in test T0209-1 is a result of the reaction itself and is a combined thermal and gas production effect.

Note that due to the above mentioned pressure increase the initial flow rate through the filter is estimated to be ≈ 0.8 cfm for test T0208-1 and ≈ 0.9 cfm for test T0209-1. In both tests the containment pressure and filter flow rate decay with time over a depressurization period of ≈ 20 min.

5.3 Aerosol Sample Collection

The collected aerosol sample is represented in Table 5-3 below. The sample was weighed and sealed in the shipping containers within 15 min. after completion of the test. As can be seen from the table, abundant particulate material was collected. Other than the sample mass, the only other noteworthy aspect of the sample collection procedure was the observation that the post-test sample weight could not be represented as a fixed value. Upon placing the filter element on the scale, a weight loss of ≈ 1 mg/min was observed to continue. No effort was made to see how long this weight loss would persist since the other concern for moisture uptake was in mind.

5.4 Overall Material Balance

The overall material balance as inferred from the pre- and post-test sample weighings are summarized in Table 5-4 below.

Table 5-4
Overall Mass Balance

Test	T0208-1	T0209-1
1. Initial Sample	50.5 gm	50.5 gm
2. Recovered Solid Residue	30.7 g	31.3 g
3. Estimated Gas Products (1 - 3)	19.8 g	19.2 g
Expected solid residue per Section 3.2	30.8 to 32.3 g	30.8 to 32.3 g

As can be seen, the accounted for solid residue is within 6% of the estimate given in Section 3.2. This also indirectly confirms the gas production of 12 to 13 mole of gas per mole of ferrocyanide. This is significant in that it is impossible to recover 100% of all solid residue. Minor amounts of un-recoverable residue are lost in the sample insulation and scale on the heater element. Nevertheless, the mass inventory accounting appears satisfactory and consistent with the expected gas generation rate.

6.0 REFERENCES

1. Letter; R. J. Cash to H. K. Fauske, "Subject: Aerosol Propagation Tests and Parametric Pressure Propagation Test", January 12, 1993.
2. FAI/92-66 (Revised), "Test Plans and Procedures for Determination of Reaction Propagation Velocity in Sodium Nickel Ferrocyanide Compounds", July, 1992.
3. FAI/92-81, "Adiabatic Calorimetry and Reaction Propagation Rate Tests with Synthetic Ferrocyanide Materials Including UPlant-1, UPlant-2, In-Farm 1, In-Farm 2, and Vendor-Procured Sodium Nickel Ferrocyanide", July, 1992.
4. FAI/93-12, "Summary Report on Parametric Pressure Propagation Test T0127-1", Jan., 1993.
5. Letter; H. K. Fauske to R. J. Cash, Subject: "Status Report on Reaction Propagation Rate Tests with Synthetic Sodium Nickel Ferrocyanide Material", September 21, 1993.

APPENDIX A

Letter from R. J. Cash to H. K. Fauske (Ref. [1])



P.O. Box 1970 Richland, WA 99352

January 12, 1993

9350199

Dr. H. K. Fauske, President
Fauske and Associates, Inc.
16W070 West 83rd Street
Burr Ridge, Illinois 60521

Dear Dr. Fauske:

AEROSOL PROPAGATION TESTS AND PARAMETRIC PRESSURE PROPAGATION TEST

Please conduct two aerosol tests and one parametric propagation test for the Ferrocyanide Safety Program at Hanford. The aerosol tests are expected to give a reasonable release fraction of aerosol particles from reaction of the most concentrated ferrocyanide waste simulant, In-Farm-1. The parametric pressure propagation test will give a propagation rate measurement for an intermediate pressure.

Perform the first aerosol release test using In-Farm-1 bottom fraction test material in a similar configuration as the propagation tests, except the aerosol tests shall be conducted in the 49 liter chamber. Use vacuum dried In-Farm-1 simulant to which 1 wt% water is added and well mixed in order to permit possible conversion of the cesium to cesium hydroxide during the reaction. Include thermocouples in the test material and within the chamber atmosphere to measure the propagation rate and containment gas/temperature responses. Perform the first test at three (3) atmospheres initial absolute pressure under argon with delayed exhaust gas venting through a filter to collect aerosol as shown in Figure 1. Other parameters should be as follows: a 25 mm diameter test material cylinder about 100 mm long, a 60 °C initial temperature, dried material (reconstituted to 1 wt% water) screened through a 140 mesh screen, and a specific gravity of about 1.2 (actual density measured).

Venting of the chamber gas should begin when the reaction is completed as determined by the temperature of the lowest thermocouple and first decrease in chamber pressure after the reaction is started (estimated to be about 30 seconds after start of the reaction). Controlled venting down to atmospheric pressure, through an orifice upstream of the filter housing, will protect the filter system and provide favorable conditions for obtaining a good aerosol sample. The orifice should be sized to control a maximum flow through the filter of 0.5 cfm. It is important that Westinghouse Hanford Company (WHC) simulant be used instead of vendor-produced material because the WHC simulant has traceable cesium in it and the vendor material does not.

H. K. Fauske
Page 2
January 12, 1993

9350199

Photographs are requested of the deposits inside of the chamber after the test. The filter papers and O rings from the aerosol filter should be weighed (to four significant figures) before and after aerosol loading to determine the mass of aerosol collected. (Rental of a balance, as necessary, to make these measurements is approved.) Quartz filter papers will be used and should be handled with tweezers only, since sodium can be picked up from human hands. Filter paper holders have been provided to you for handling and shipping purposes.

It is desirable to make a material balance on the cesium and other metallic elements during this test. The inside of the chamber should be lined with aluminum foil to collect any cesium plate-out on exposed surfaces. The aerosol should be removed from the vent gas by filtering, and all of the remaining solid reaction products should be weighed. The gas samples, loaded filter paper, solid reaction products, and foil liner should be returned to WHC for analysis as soon as possible after completion of each test.

Perform the second aerosol test at an initial temperature of 120 °C but with all other conditions kept the same as the first test; the same data measurements should be made. It is expected that the 1 wt % water added to the test material will be retained within the sample at 120 °C up to the point of ignition of the second test reaction.

Please submit the aerosol propagation test procedure for WHC approval prior to conducting these tests.

It is requested that you perform one additional propagation test at an initial pressure of 10 atmospheres absolute using an argon environment. Use dry (0 wt% water) In-Farm-1 bottom fraction material for this test, the 25 mm diameter test bed, an initial temperature of 60 °C, a specific gravity of about 1.2 (actual density measured), and a particle size as screened through a 140 mesh screen. This test can be conducted in the 49 liter chamber, if you choose. Obtain a gas sample of the containment atmosphere before and after the reaction. Please provide a detailed gas sampling procedure for approval prior to conducting this test. Use of the WHC-provided samplers (NUPRO) with end caps to provide a second seal and to protect threaded connections is requested. Please report the results of these tests, including the temperatures of the chamber gas as a function of time, in a summary report, available for public release.

Please provide measured gas temperatures within the containment atmosphere (and provide the location of the thermocouples) as a function of time for each propagation test conducted to date with the disodium mononickel ferrocyanide mixtures. The gas temperatures and pressure measurements during the reaction time and during cooling time are desired. Temperature and pressure measurements of the containment gas atmosphere are also needed at the time that the gas samples were/are obtained. Your prompt response to this request for tests completed to date would be appreciated.

H. K. Fauske
Page 3
January 12, 1993

9350199

About 1.4 kg of additional In-Farm-1 bottom fraction simulant material was shipped to you on January 5, 1993. The composition of the In-Farm-1 bottom fraction simulant is still being determined by laboratory analysis and will be provided to you in the near future so that the final six screening propagation tests can be conducted. About one Kg of U-Plant-1 sludge will be prepared and shipped to you for the bake out tests discussed at the December 9 and 10, 1992 meeting at Hanford. Additional gas sampler (NUPRO) containers are also being shipped to you.

For your information the gas analysis of the containment atmosphere gases for four propagation tests conducted previously are listed in Table 1. It should be noted that analytical results of two of the pretest samples indicate that there is a concern about the initial condition of the test chamber atmosphere. Either the gas sampling was not conducted properly or the containment atmosphere was not adequately purged. See footnotes of Table 1.

Please address questions to D. W. Jeppson at (509) 376-6058 or to me at (509) 373-3132.

Very truly yours,



R. J. Cash, Manager
Ferrocyanide Safety Technology
Tank Waste Remediation System

fm

TABLE 1
 Gas Analysis of Containment Gases for Propagation Tests

Sample	Mole %											
	CO ₂	Ar	O ₂	N ₂	CO	He	H ₂	CH ₄	N ₂ O	NO	NO ₂	SO ₂
T0820-1-Pre	<0.01	99.99	<0.01	0.003	<0.10	<0.01	<0.01	<0.01	<0.01	<0.01	<0.01	<0.01
T0820-1-After	1.08	95.4	0.26	3.26	<0.10	<0.01	<0.01	<0.01	<0.01	0.02	<0.01	<0.01
T0821-1-Pre	0.02	92.1	1.62	6.27	<0.10	<0.01	<0.01	<0.01	<0.01	<0.01	<0.01	<0.01
T0821-1-After	14.8	24.2	0.04	45.7	<0.10	<0.01	0.03	<0.01	<0.01	15.3	<0.01	<0.01
T0825-1-Pre*	0.10	54.6	9.21	36.1	<0.10	<0.01	<0.01	<0.01	<0.01	<0.01	<0.01	<0.01
T0825-1-After	3.90	84.8	0.09	11.2	<0.10	<0.01	0.01	<0.01	<0.01	0.01	<0.01	<0.01
T0826-1-Pre	<0.01	99.98	<0.01	0.02	<0.02	<0.01	<0.01	<0.01	<0.01	<0.01	<0.01	<0.01
T0826-1-After	0.61	97.5	0.03	1.75	<0.10	<0.01	0.02	<0.01	<0.01	0.01	<0.01	<0.01

* This sample bottle (FAL supplied) was at low pressure and the valve was reported by the analytical laboratory to be leaking.

Note: Sample T0821-1-Pre results may imply that adequate purging of the chamber was not done prior to performance of the test.

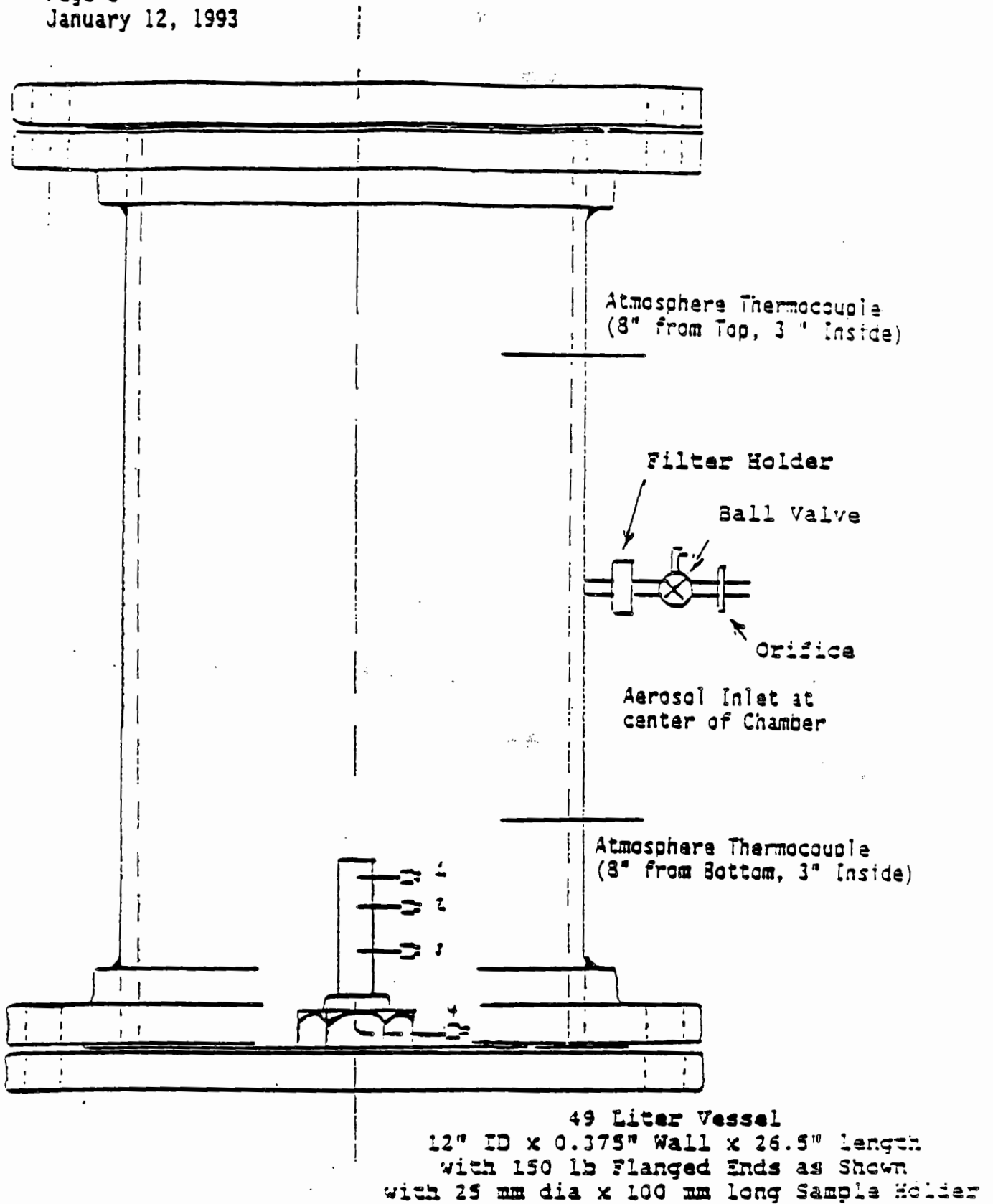

Figure 1
Aerosol Test Containment Vessel

APPENDIX B
Microbalance Calibration

**Calibration Data Sheet for
SARTORIUS Microbalance Scale**

1st Trial

<u>Test Wgt.</u>	<u>Scale Reading</u>
1 mg	0.00101 gm
10 mg	0.01000 gm
100 mg	0.10007 gm

2nd Trial

<u>Test Wgt.</u>	<u>Scale Reading</u>
1 mg	0.00102 gm
10 mg	0.01001 gm
100 mg	0.10004 gm

Date: 2-5-93

Calibration Standards

1 mg Class 1 wgt.	H138023191TIU
10 mg Class 1 wgt.	H138023191PP
100 mg Class 1 wgt.	H318023191KIL

*** All wgt. are ASTM Tolerance Class 1 ***

APPENDIX C

Test Data Sheets for Tests T0208-1 and T0209-1

Sample Preparation

Preliminary: Test ID # T0208-1 Date 8 Feb 93

Step	Activity	Record or Check
1.	Measure 50 gm of vacuum dried and sieved In-Farm-1 bottom sample into clean glass beaker.	<u>199.0 g</u> <input checked="" type="checkbox"/>
	Glass beaker tare weight	<u>149.0 g</u>
2.	Add .5 gm distilled and demineralized water. mix thoroughly	<u>0.50 g</u> <input checked="" type="checkbox"/>
3.	Record total weight of container and sample.	<u>199.5 g</u> <input checked="" type="checkbox"/>
4a.	Record weight of empty sample holder.	<u>161.79 g</u>
4b.	Add sample to sample holder packing with clean glass rod.	<input checked="" type="checkbox"/>
5.	After loading is complete (Step 4) record:	
	Weight of source beaker and residue.	<u>149.03 g</u>
	Weight of loaded test sample holder.	<u>212.26 g</u>
	net charge 50.47 g	
	Depth of charge in sample holder.	<u>"1/32" from top</u>
	"	
6.	Finish sample holder assembly and dressing -	
	• heaters (2)	
	• thermocouples (4)	
	• insulation with foil	
	and 2 1/4 wire leads + 1/4 wire	
	Record assembled weight.	<u>336.8 g</u>

Step	Activity	Record or Check
7.	<p style="text-align: center;"><i>two to four</i></p> Prepare a two gram charge of barium peroxide/aluminum starter mix in an 25 mm dia. aluminum foil cup and record total weight. Hold for adding to test sample later (step 11).	<p style="text-align: right;"><i>2.23 g igniter</i></p> <p style="text-align: right;"><u><i>4.23g total</i></u></p> <p style="text-align: right;"><input checked="" type="checkbox"/></p>

Filter Preparation

8a.	Weigh clean unused filter element.	<u><i>See below</i></u>
8b.	Install in filter housing per Fig. 2-4 taking care to use only tweezers.	<input checked="" type="checkbox"/>

Containment Vessel Preparation

9.	Containment vessel fittings and seals have been previously checked for leak-tightness.	<input checked="" type="checkbox"/>
10.	Containment vessel is open and cleaned of all prior test residue.	<input checked="" type="checkbox"/>
11.	Line all inside surfaces of containment vessel with aluminum foil and record weight of foil used.	<u><i>See Data Sheet</i></u>
12a.	Install assembled test sample holder on bottom flange of containment vessel and secure all internal connections.	<input checked="" type="checkbox"/>
12b.	Install igniter mix and igniter.	<input checked="" type="checkbox"/>
12c.	Take photograph of sample holder.	<input checked="" type="checkbox"/>

	Pre test (mg)	Post Test (mg)	
filter element	<u>154.71</u>	<u>520 +</u>	→ started at 530 + mg; lost wgt at rate of 2.1 mg/min note of proceed
O-Ring	<u>2445.15</u>	<u> </u>	
filter element + O-Ring	<u>2599.86</u>	<u> </u>	
	C-3	<u>2966.01</u>	

Step	Activity	Record or Check
------	----------	-----------------

13. Seal containment vessel and purge five times between full vacuum and 0 psig with Argon gas.

Cycle	Vacuum	Fill
1	<u>28"</u>	<u>10 psig</u>
2	<u>28"</u>	<u>10 psig</u>
3	<u>28"</u>	<u>10 psig</u>
4	<u>28"</u>	<u>10 psig</u>
5	<u>28"</u>	Test Pressure <u>30 psig</u>

At end of 5th cycle Argon pressure should be set to test pressure.

Record pressure.

31 psig

14. Hold test pressure during instrument checkout.

15. Set up instruments and check proper alignment.

Check proper calibration setup.

Notes P cal 16 psi/volt
TC all OK

16. Verify containment is holding pressure.

Test Sequence

17. Verify heater circuit continuity.

18. Verify igniter circuit continuity.

Step	Activity	Record or Check
19.	Begin heating sample up to test temperature. When TC #3 is at test temperature, record temperatures.	Start fast data 0.00 sec Stop fast data 67 73.13 sec Start slow data 118.8 sec
	TC #1 _____ °C <u>44</u> °C TC #2 _____ °C <u>61</u> °C TC #3 _____ °C <u>62</u> °C TC #4 _____ °C <u>43</u> °C TC #5 _____ °C <u>20</u> °C TC #6 _____ °C <u>19</u> °C	
20.	Verify TC #4 is being recorded on strip chart recorder.	<input checked="" type="checkbox"/>
21.	Verify data acquisition system is ready.	<input checked="" type="checkbox"/>
22.	Verify igniter system is ready.	<input checked="" type="checkbox"/> <i>at start of test</i> <i>P = 27.8 - 30 psig</i>
23.	Start data acquisition system and on operator signal close igniter circuit.	<input checked="" type="checkbox"/>
24.	On response of TC #4 to burn open filter vent.	<input checked="" type="checkbox"/>
25.	When containment pressure has fallen to 0 psig close filter vent.	<input checked="" type="checkbox"/>
26.	Stop data taking.	<input checked="" type="checkbox"/>

Post-Test Activities

- 27a. Weigh filter paper, and O-Ring and quickly - - - see data on prev page
- 27b. Insert in filter paper holder for shipment and label with test ID #. _____
- 28. Open containment vessel and take photographs. _____ ✓
- 29a. Weigh test sample holder. *Ref item 6* 314.2g
C25

Step	Activity	Record or Check
29b.	<i>Weight of undressed sample holder</i> Weigh loose solid metal. <i>comparable to item 5</i>	<u>197.6 g</u>
29c.	Weigh all foil material.	<u>see data sheet</u>
29d.	Total weight of material in containment vessel.	<u>30.36 g</u>
30.	Reduce test data.	<input checked="" type="checkbox"/>
31.	Clean test apparatus and prepare for follow-on test.	<input checked="" type="checkbox"/>

4.4 Data Reporting

As customary, FAI will advise WHC of individual test results by phone and advise or discuss any variations from the expected operating procedure.

After the second aerosol test, a detailed report of the test data including all temperatures and pressures will be provided. Special sections will detail the gravimetric analysis and note the filter paper weight gain. Test photographs will be submitted to WHC under separate transmittal.

Post-test debris and filters will be sent to WHC for further evaluations of the test data.

336.8 g	Sample	50 g
<u>314.2 g</u>	mass lost	<u>22.6 g</u>
22.6 g	residue	27.4 g
	residue on foil	<u>2.96</u>
	Total residue accounted 30.36	
	for	
	initial mass defect	19.64 g
	Estimated gas production 17 to 14 g	

Test T0208-1

Pre & Post Test Liner foil wgt

Element	Pre Test wgt	Post Test wgt
Bottom	8.87 g	
head wraps cover	8.65 g 1.50 g	
sub total bottom	<u>19.02 g</u>	21.3 g
Side	56.52 g	57.1 g
Top	8.6 g	8.7 g
Total	<u>84.14 g</u>	<u>87.1</u>
Net gain in wgt		2.96 g

DATE: 8 Feb 93

WHC AEROSOL TEST

TOZOR-1

TEST PRESSURE

30 psig nom

SAMPLE TEMPERATURE

60°C nom

Sample Holder 25 mm dia x 101 mm lg

Verify Dimensions

Overall Height

TC 1 $3/8$ No. 72

TC 2 $1\ 3/16$ No. 69

TC 3 $2\ 1/32$ No. 27

TC 4 $7/32$ No. 50

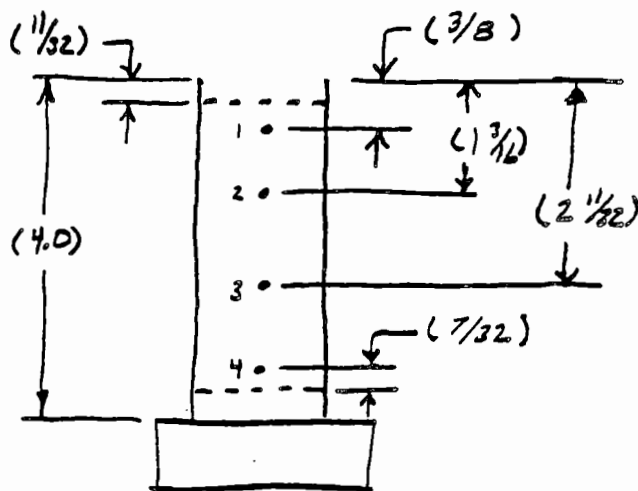

Containment 49 L

TC 5 8" bottom 3" wall No. 104 bottom

TC 6 18.5" bottom 3" wall No. 105 top

Pressure Transducer

Range 80 psi (fs)

Cal Fac 16 $\frac{psf}{vol}$

Sample: IN-FARM 1 Bottom w 1w% H₂O

Source Ref IN-FARM 1B Rev 6A Bottom 60% 12-21-92

Vec dried & screened through 140 mesh

Sample Wgt 50.47 gm SG. 1.32

Sample Hgt. 11/32" from top

Igniter Charge 2.23 gm

Date 8 Feb 93
 Test T0208-1

Calculation of Sample Packed Density

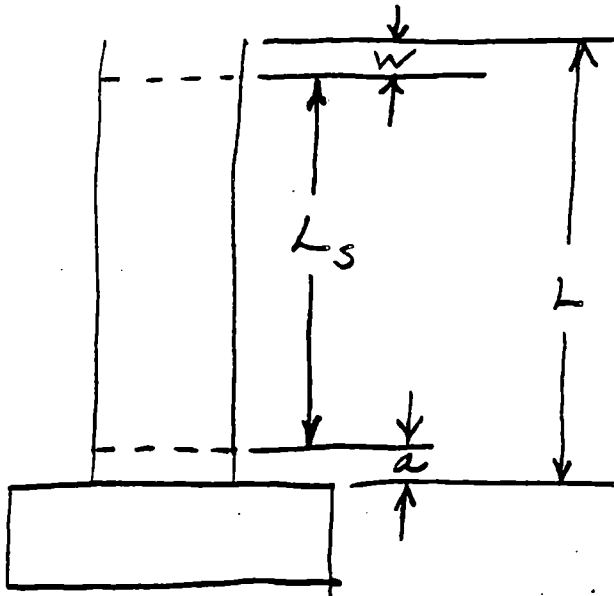

Sample Wgt

$$M_s = \underline{50.47} \text{ gm}$$

D	<u>25</u>	mm		
L	<u>4.0</u>	inch	<u>101.6</u>	mm
a	<u>0.59</u>	inch	<u>15</u>	mm
w	<u>11/32</u>	inch	<u>8.7</u>	mm

$$L_s = L - (a + w) = \underline{77.9} \text{ mm}$$

USE DIMENSIONS IN (mm)

$$V_s = \frac{\pi D^2}{4} L_s \times 10^{-3} = \underline{38.24} \text{ cm}^3$$

$$\text{Packing Density} = \frac{M_s}{V_s} = \frac{50.47}{38.24} = \underline{1.32} \frac{\text{gm}}{\text{cm}^3}$$

Sample Preparation

Preliminary:

Test ID # T0209-1

Date 9 Feb 93

Step	Activity	Record or Check
1.	Measure 50 gm of vacuum dried and sieved In-Farm-1 bottom sample into clean glass beaker. (Used stainless steel cup) Glass beaker tare weight	<u>199.0 g</u> <input checked="" type="checkbox"/> <u>149.0 g</u>
2.	Add .5 gm distilled and demineralized water. mix thoroughly	<u>.50 g added</u> <input checked="" type="checkbox"/>
3.	Record total weight of container and sample.	<u>199.5 g</u> <input checked="" type="checkbox"/>
4a.	Record weight of empty sample holder. with TC4 and no heaters	<u>161.83 g</u>
4b.	Add sample to sample holder packing with clean glass rod.	<input checked="" type="checkbox"/>
5.	After loading is complete (Step 4) record: Weight of source beaker and residue. Weight of loaded test sample holder. net charge 50.46 g Depth of charge in sample holder.	<u>149.0 g</u> <u>212.29 g</u> <u>5/16" from top</u>
6.	Finish sample holder assembly and dressing - • heaters (2) • thermocouples (4) • insulation with foil and 2 leads and igniter Record assembled weight.	<u>345.6 g</u>

Step	Activity	Record or Check
7.	<p style="text-align: center;"><i>two to four</i></p> Prepare a two gram charge of barium peroxide/aluminum starter mix in an 25 mm dia. aluminum foil cup and record total weight. Hold for adding to test sample later (step 11).	<p>(.14g per wgt) (4.15g ign wgt)</p> <p style="text-align: center;"><u>4.29g</u></p> <p style="text-align: right;"><input checked="" type="checkbox"/></p>

Filter Preparation

- 8a. Weigh clean unused filter element. see below
- 8b. Install in filter housing per Fig. 2-4 taking care to use only tweezers.

Containment Vessel Preparation

- 9. Containment vessel fittings and seals have been previously checked for leak-tightness.
- 10. Containment vessel is open and cleaned of all prior test residue.
- 11. Line all inside surfaces of containment vessel with aluminum foil and record weight of foil used. see data sheet
- 12a. Install assembled test sample holder on bottom flange of containment vessel and secure all internal connections.
- 12b. Install igniter mix and igniter.
- 12c. Take photograph of sample holder.

	Pre test (mg)	Post Test (mg)
filter element	<u>155.46</u>	<u>749.30</u>
O-Ring	<u>2445.12</u>	<u>2446.06</u>
filter element + O-Ring	<u>2600.64</u>	C-11 <u>3196.40</u>

Step	Activity	Record or Check
------	----------	-----------------

13. Seal containment vessel and purge five times between full vacuum and 0 psig with Argon gas.

<u>Cycle</u>	<u>Vacuum</u>	<u>Fill</u>
1	<u>28"</u>	<u>10 psig</u>
2	<u>28"</u>	<u>10 psig</u>
3	<u>28"</u>	<u>10 psig</u>
4	<u>28"</u>	<u>17 psig</u>
5	<u>28"</u>	Test Pressure <u>30 psig</u>

At end of 5th cycle Argon pressure should be set to test pressure.

Record pressure.

30 psig

14. Hold test pressure during instrument checkout.

15. Set up instruments and check proper alignment.

Check proper calibration setup.

Notes Recal 16 psi/volt

TC all OK

16. Verify containment is holding pressure.

Test Sequence

17. Verify heater circuit continuity.

18. Verify igniter circuit continuity.

Step	Activity	Record or Check
29b.	<i>wgt of undressed sample holder</i> Weigh loose solid metal. <i>comparable to item 5</i>	<u>193.6 g + 1.7g</u> <u> g - 0g</u>
29c.	Weigh all foil material.	<u>see data sheet</u>
29d.	<i>sample residue</i> Total weight of material in containment vessel <i>accounted for in mass balance see below</i>	<u>31.34 g</u>
30.	Reduce test data.	<input checked="" type="checkbox"/>
31.	Clean test apparatus and prepare for follow-on test.	<input checked="" type="checkbox"/>

4.4 Data Reporting

As customary, FAI will advise WHC of individual test results by phone and advise or discuss any variations from the expected operating procedure.

After the second aerosol test, a detailed report of the test data including all temperatures and pressures will be provided. Special sections will detail the gravimetric analysis and note the filter paper weight gain. Test photographs will be submitted to WHC under separate transmittal.

Post-test debris and filters will be sent to WHC for further evaluations of the test data.

		<i>For 29d use</i>
345.6	212.29	sample 50 g
- 322.0	- 193.6	mass lost <u>23.6 g</u>
<u>23.6 g</u>	<u>18.69</u>	residue 26.4 g
		residue on foil 4.94
		Total residue <u>31.34</u>
		accounted for
		<i>initial mass defect 18.66 g</i>
		<i>C-14 estimated gas production 17 to 19 g</i>

Test T0209-1

Pre & Post Test Liner foil wgt

Element	Pretest wgt	Post Test wgt
Bottom	7.88 g	
Lead wraps	11.18	
cover	1.50 g	
sub total bottom	<u>20.56 g</u>	23.96 g
Side	56.05 g	57.26 g
Top	8.17 g	8.50 g
Total	<u>84.78 g</u>	<u>89.72 g</u>
Net gain in weight		4.94 g

DATE: 9 Feb 93

WHC AEROSOL TEST

T0209-1

TEST PRESSURE

30 psi nom

SAMPLE TEMPERATURE

120°C nom

Sample Holder 25 mm dia x 101 mm lg

Verify Dimensions

Overall Height

TC 1	3/8	No. 58
TC 2	1 3/16	No. 51
TC 3	2 23/64	No. 46
TC 4	1/8	No. 49

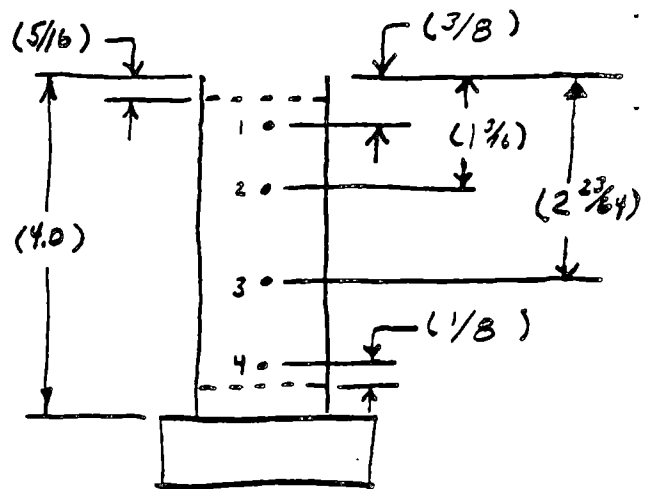

Containment 49 h

TC 5	<u>8" bottom 3" wall</u>	No. <u>104</u>	bottom
TC 6	<u>11.5" bottom 3" wall</u>	No. <u>105</u>	top

Pressure Transducer

Range 80 psi (fs)Cal Fac 16 $\frac{\text{psi}}{\text{vol}}$ Sample: IN-FARM 1 BOTTOM w 1w% H₂OSource Ref INFARM 1B Rev 6A Bottom 60% 12-21-92Vac dried & screened through 140 meshSample Wgt 50.46 SG. 1.31Sample Hgt. 5/16 from topIgniter Charge 4.15 gm

Date 9 Feb 93
 Test T0209-1

Calculation of Sample Packed Density

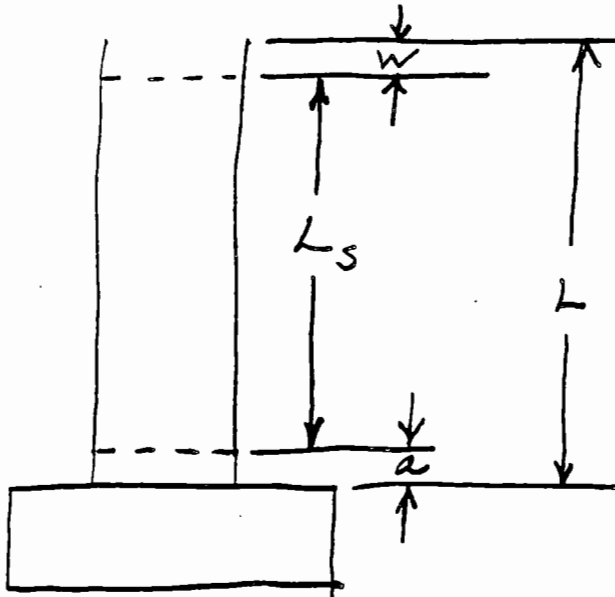

Sample Wgt

$$M_s = \underline{50.46} \text{ gm}$$

D	<u>25</u>	mm		
L	<u>4.0</u>	inch	<u>101.6</u>	mm
a	<u>0.59</u>	inch	<u>15</u>	mm
w	<u>5/16</u>	inch	<u>7.9</u>	mm

$$L_s = L - (a + w) = \underline{78.7} \text{ mm}$$

USE DIMENSIONS IN (mm)

$$V_s = \frac{\pi D^2}{4} L_s \times 10^{-3} = \underline{38.63} \text{ cm}^3$$

$$\text{Packing Density} = \frac{M_s}{V_s} = \frac{50.46}{38.63} = \underline{1.31} \frac{\text{gm}}{\text{cm}^3}$$

TABLE OF CONTENTS

	<u>Page</u>
1.0 INTRODUCTION AND SUMMARY	1-1
2.0 TEST EQUIPMENT	2-1
2.1 Reaction Ignition Source	2-1
3.0 TEST MATERIALS	3-1
4.0 TEST PROCEDURES	4-1
5.0 TEST RESULTS	5-1
5.1 Propagation Rate Data	5-1
5.2 Overall Containment Environment Response	5-3
5.3 Post-Test Observations	5-3
5.4 Gas Evolution Assessment	5-3
6.0 COMPARISON WITH OTHER RELATED RESULTS	6-1
7.0 REFERENCES	7-1
APPENDIX A: Letter from R. J. Cash to H. K. Fauske, (Ref. [1]) . . .	A-1
APPENDIX B: Test Procedures	B-1
APPENDIX C: Miscellaneous Test Data Records	C-1

LIST OF TABLES

<u>Table No.</u>		<u>Page</u>
3-1	Material Assay of In-Farm-1 Bottom Flow Sheet Sample	3-1
3-2	Final As-Tested Sample Parameter	3-2
5-1	Reaction Speed Data for Test T0128-1	5-1
6-1	Comparison of Related Propagation Rate Tests	6-1

LIST OF FIGURES

<u>Figure No.</u>		<u>Page</u>
2-1	Overall test equipment configuration	2-2
2-2	High pressure containment vessel used for burn velocity tests	2-3
2-3	25 mm diameter sample holder used in burn velocity tests	2-4
5-1	Thermocouple response to reaction propagation for Test T0128-1, 52 atm. 60°C, 25 mm diameter sample holder, dry InFarm-1 bottom sample	5-2
5-2	Containment response to reaction from Test T0128-1	5-4
5-3	Expanded scale of containment thermocouple response	5-5

1.0 INTRODUCTION AND SUMMARY

This report presents the results of the second test conducted in a series of tests directed by Westinghouse Hanford Company (WHC) in Ref. [1]. For the record, Ref.[1] is included as Appendix A. The test discussed in this document, designated as T0128-1, is a ferrocyanide reaction propagation rate determination test conducted under an inert argon atmosphere of 52 atm. abs. (745 psig). The test was conducted in a 4 L containment volume described in Section 2.0. The test sample was dry In-Farm 1 bottom flow sheet material described in Section 3.0. The test protocol was similar to that described in Refs. [2 and 3]. However, as requested in Ref.[1] supplemental gas sample taking procedures were prepared and followed as described in Section 4.0 and Appendix B.

Test results showed an inverse reaction propagation velocity of ≈ 2 sec/cm. This is about two times faster than observed with the same material under a pressure of 10 atm. abs. and about four times slower than observed in a prior test at 50 atm. pressure using VWV sample. Pre- and post-test gas samples were taken and have been forwarded to WHC for further analyses. Details of these results are presented in Section 5.0 and comparisons with other similar reaction propagation rate tests are discussed in Section 6.0.

2.0 TEST EQUIPMENT

The overall test equipment configuration is shown in Fig. 2-1. This configuration is similar to the configuration used in earlier tests, Ref. [2]. The 4 L containment vessel and environment thermocouple locations are shown in Fig. 2-2. Fig. 2-3 shows details of the 25 mm diameter sample holder. The sample holder is a 0.002 inch thick, type 316 stainless steel sheet rolled onto a 25 mm diameter mold, spot welded to hold a round tube configuration and trimmed to 4 inches in overall length. This tube (considered to be disposable) is slipped over the base stand as shown in Fig. 2-3. After the sample tube is filled with the test sample material, a spiral heater coil is positioned on the outside of the tube wall and type K thermocouples of 0.020 inch diameter are located at the indicated axial elevations.

2.1 Reaction Ignition Source

The use of a barium peroxide and aluminum mixture has proven to be an effective starter for the ferrocyanide reaction. This starter mixture can be ignited with a hot wire. The stoichiometric reaction is written as

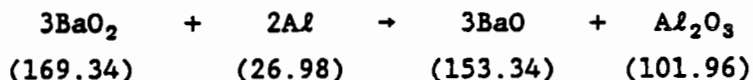

Numbers in () under the above reaction represent the formula weights of the reactants and products. Thermochemical evaluation of this stoichiometric relation indicates the heat of reaction is estimated to be -338 kcal/g-mole BaO₂ or ≈ 9.5 MJ/kg BaO₂. The estimated reaction temperature increase is of the order of 2000°C. This reaction is used to initiate the thermite reactions (Fe₂O₃ + 2Al → 2Fe). The barium peroxide-aluminum reaction as written does not appear to be gassy. Barium oxide, mp 2000°C, bp 3100°C, appears to be quite stable (Al₂O₃ has a boiling point of 2900°C). However, BaO₂ is reported to decompose to Ba and O₂ at 800°C. This could be a source of gas, albeit small, for this ignition method. The barium peroxide/Al starting

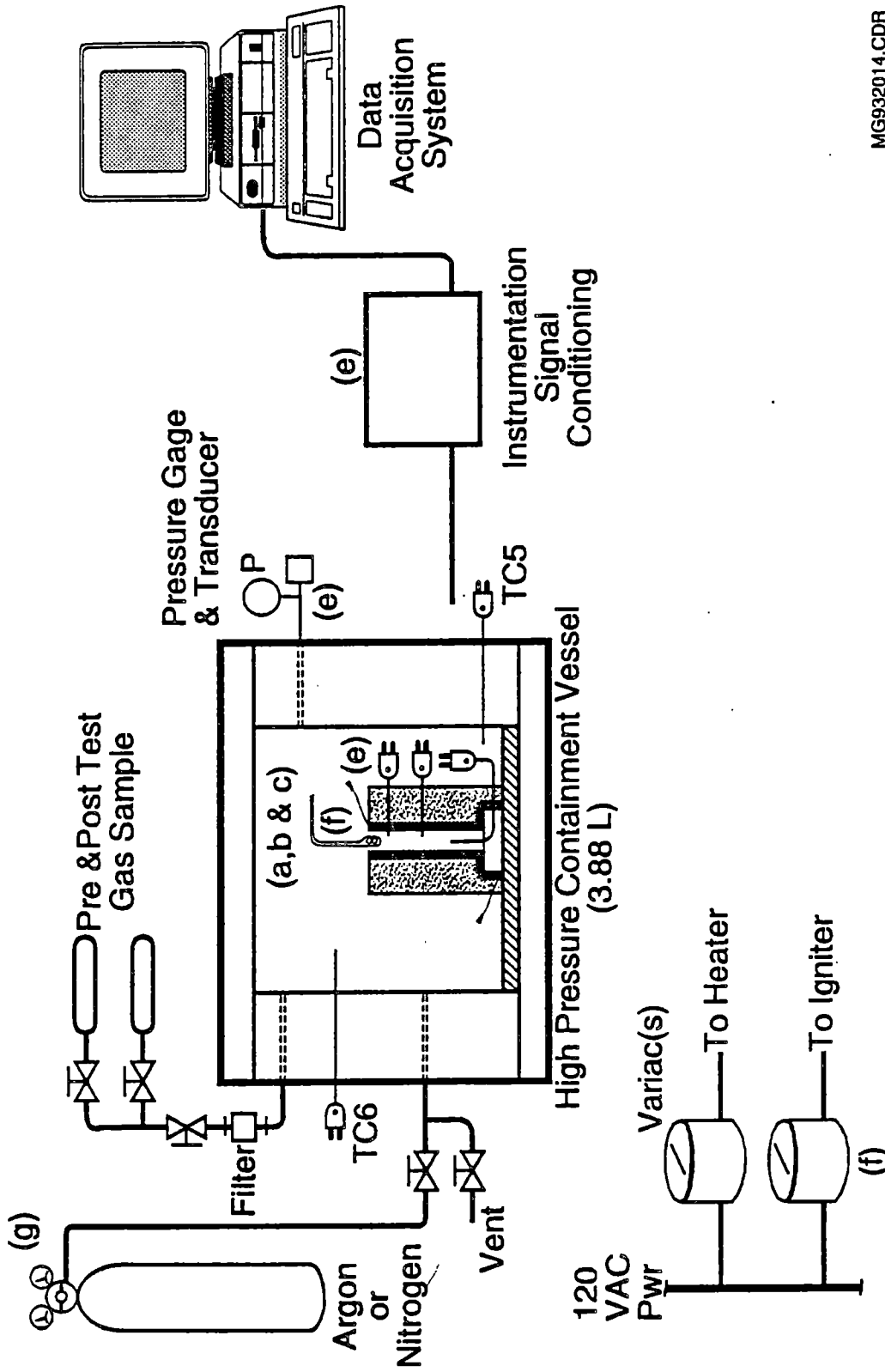

MG932014.CDR

Fig. 2-1 Overall test equipment configuration.

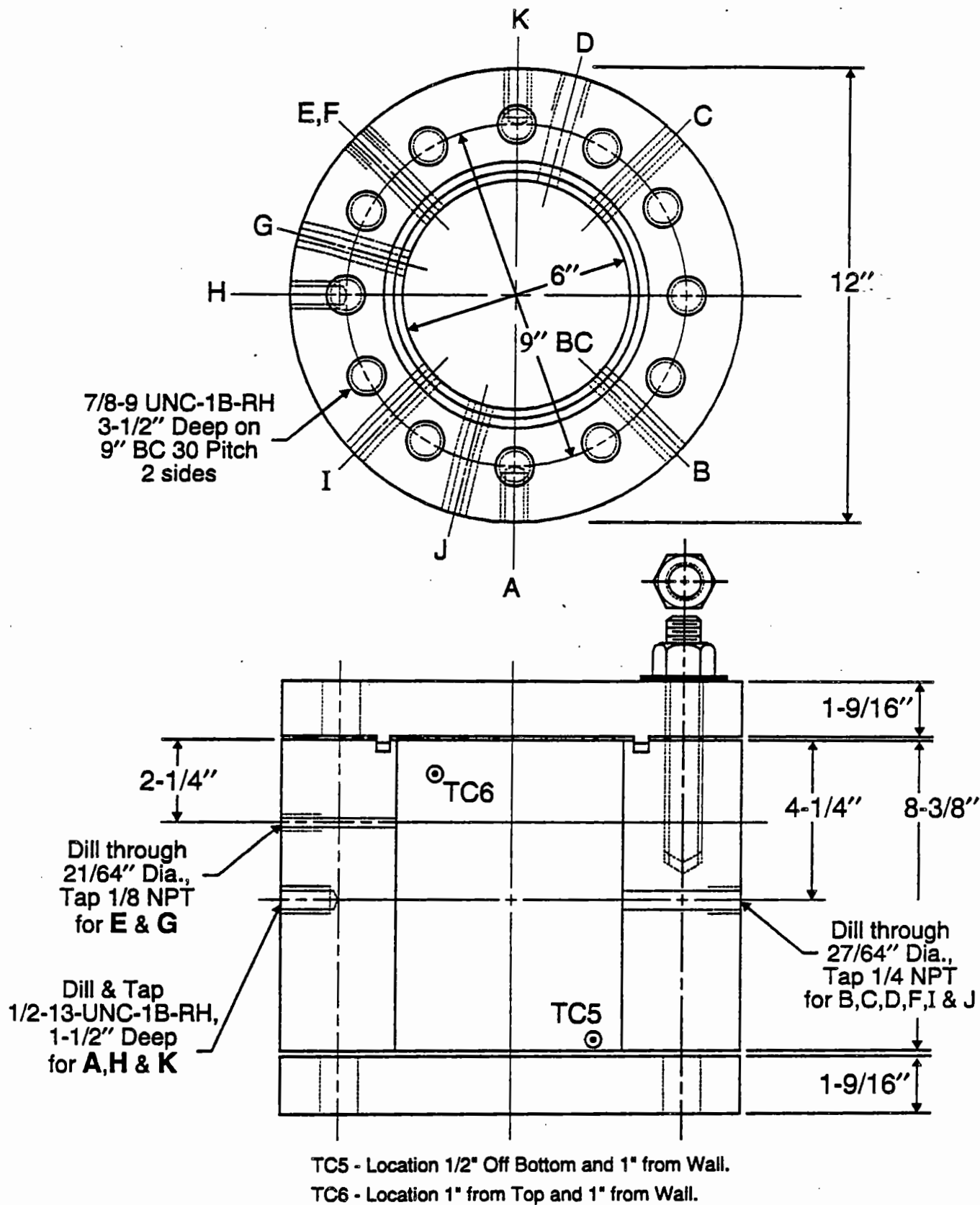

MG932027.CDR

Fig. 2-2 High pressure containment vessel used for burn velocity tests.

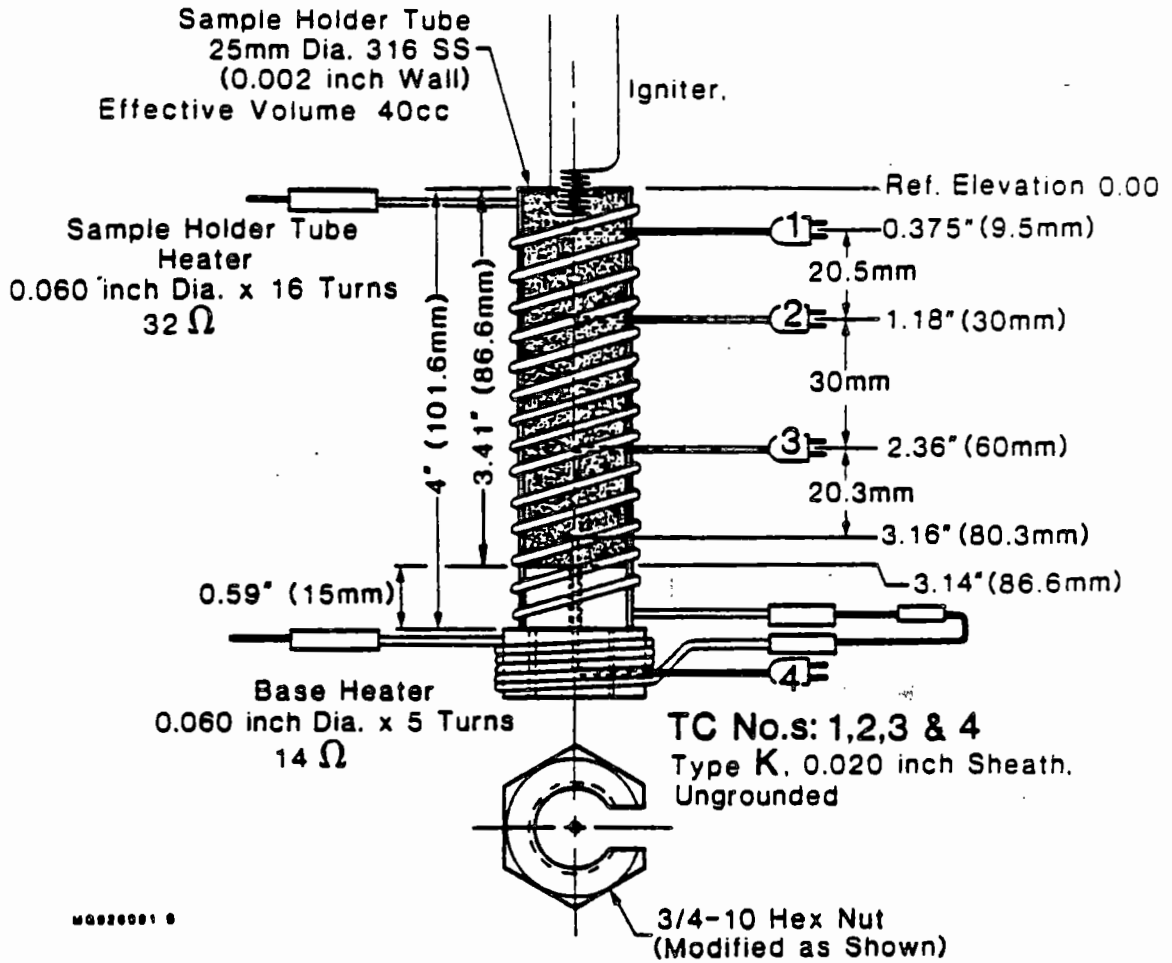

MO920001 9

Fig. 2-3 25 mm diameter sample holder used in burn velocity tests.

mixture will be separated from the ferrocyanide column by a thin aluminum foil. The ignition method has been used as described in previous propagation rate studies, Ref. [2].

3.0 TEST MATERIALS

The test sample used in this test, T0127-1, was In-Farm 1 bottom flow sheet material received from WHC. The material was vacuum dried and then sieved through a 140 mesh U.S. standard screen having a 106 μ mean particle size. The test sample assay is estimated to be as stated in Table 3-1 based on information provided by WHC.

**Table 3-1
Material Assay of
In-Farm-1 Bottom Flow Sheet Sample**

Material	Wt. %
--Fe(CN) ₆	26.0
NaNO ₃	50.0
NaNO ₂	12.2
Na ₃ PO ₄	5.2
Na ₂ SO ₄	3.8
NiS	<u>2.8</u>
TOTAL	100.0
Fuel/Oxidizer Ratio	.418

--Fe(CN)₆ is estimated to be 93.8% Na₂NiFe(CN)₆ and 6.1% NaCsNiFe(CN)₆.

The test sample charge was 49.8 gm packed in the sample holder to a packing density of 1.33 gm/cm³. After the ferrocyanide sample was loaded and packed, 4.4 gm of barium peroxide/aluminum igniter mixture were placed in the top 13/32 inch of the sample holder in a thin aluminum foil pan.

The final as-tested sample parameters are summarized in Table 3-2 below.

**Table 3-2
Final As-Tested Sample Parameters**

Test Sample	InFarm-1 Bottom per Table 3-1		
Water Content	Dry		
Particle Size	106 μ		
Sample Packing Density	1.33 gm/cm ³		
Containment Pressure	52 atm abs		
Sample Holder Diameter	25 mm		
<u>Pre-Test Sample Temperature:</u>			
TC1	TC2	TC3	TC4
46°C	68°C	69°C	50°C
<u>Pre-Test Containment Volume Temperature and Pressure:</u>			
TC5	TC6	P	
22°C	29°C	745 psig	

In addition to the physical test sample parameters, Table 3-2 lists the actual pre-ignition test conditions as recorded just prior to the sample burn.

4.0 TEST PROCEDURES

Procedures identified in Ref. [3] and Appendix B were followed in the conduct of the test. Pre- and post-test containment volume gas samples were taken, identified and forwarded to WHC for further analysis.

5.0 TEST RESULTS5.1 Propagation Rate Data

The thermocouple data which indicate the linear reaction velocity are shown in Fig. 5-1. Table 5-1 indicates the various speed measurements which can be obtained from these data.

Table 5-1
Reaction Speed Data for Test T0128-1

TC#	Location* mm	Time sec	Reaction Propagation Rate
TC1	9.53	16.6	TC1 → TC2 6.88 mm/sec
TC2	30.16	19.6	TC2 → TC3 4.59 mm/sec
TC3	59.53	26.0	TC3 → TC4 5.19 mm/sec
TC4	81.85	30.3	TC1 → TC4 5.28 mm/sec

*From top of sample holder.

An overall average reaction velocity in the 25 mm diameter sample holder at 53 atm. abs. is ≈ 0.53 cm/sec. (31.8 cm/min).

Thermocouple TC3 showed a response coincident with TC1. Similar erratic behavior has been noticed in prior tests due to melting sample or initiator eruptions. However, a second response of TC3 at 26 sec. (see Fig. 5-1) is taken as the best indication of the reaction front passing. As can be seen from Table 5-1, this judgement leads to a fairly consistent estimate of speed between TC locations 2 and 4 (good response locations). The average reaction speed between TC2 and TC4 is 4.83 mm/sec. The overall

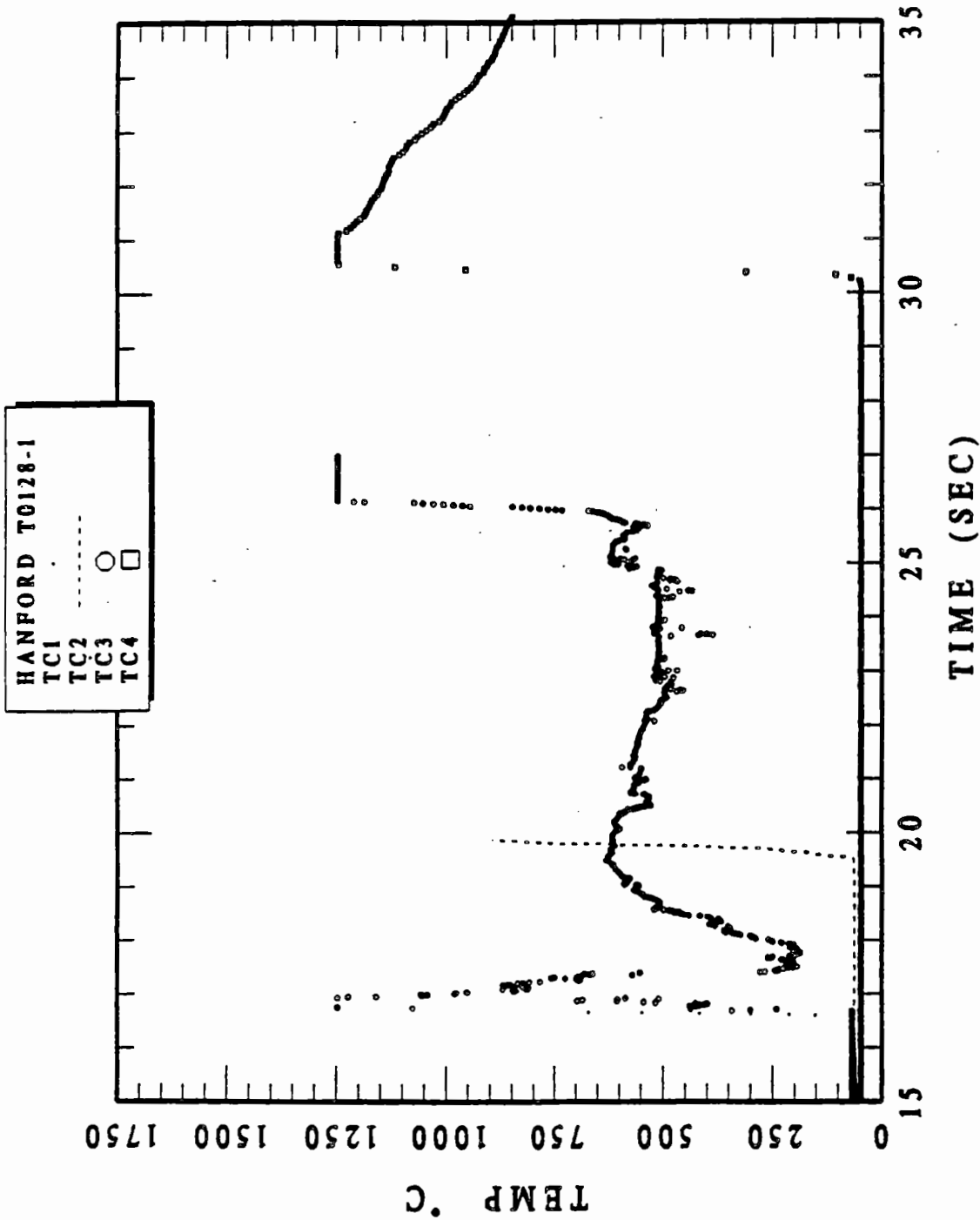

TIME VS TC1, TC2, TC3, TC4

Fig. 5-1 Thermocouple response to reaction propagation for Test T0128-1, 52 atm, 60°C 25 mm diameter sample holder, dry InFarm-1 bottom sample. Average propagation velocity .53 cm/sec.

average of 5.28 mm/sec is a result of the faster reaction velocity between locations TC1 and TC2. This may be a result of an initial "kick" provided by the hot initiator.

5.2 Overall Containment Environment Response

Fig. 5-2 provides the overall containment pressure and temperature response. The location in time for the post-test gas sample is shown in Fig. 5-2. Fig. 5-3 shows an expanded scale for the containment thermocouples.

5.3 Post-Test Observations

This sample did not burn as hot as noted in Ref. [4]. The long term cooldown containment pressure was 779 psig \pm 2 psig at a temperature of 25°C \pm 3°C. This represents an isothermal containment pressure increase of \approx 779 psig - 745 psig = 34 psig. Note that a post-test gas sample was also collected representing 50 cc volume at \approx 937 psig.

5.4 Gas Evolution Assessment

In this test, T0128-1, the containment volume was not vented (except for the gas sample) until after the temperature cooled down to 25°C. At this time the containment pressure was recorded as 779 psig. The isothermal containment volume pressure change was

$$\begin{aligned} \text{Post-Test pressure} & \quad 779 \text{ psig} \\ \text{Pre-test pressure} & \quad \underline{795 \text{ psig}} \\ \Delta P & = 34 \text{ psig} \end{aligned}$$

One can estimate the gas evolution from the reaction according to an ideal gas relation such as

$$\frac{dn}{n} = \frac{dP}{P} + \frac{dV}{V} \tag{5-1}$$

HANFORD T0128-1
TC5 - - - - -
TC6 - - - - -
PI ○

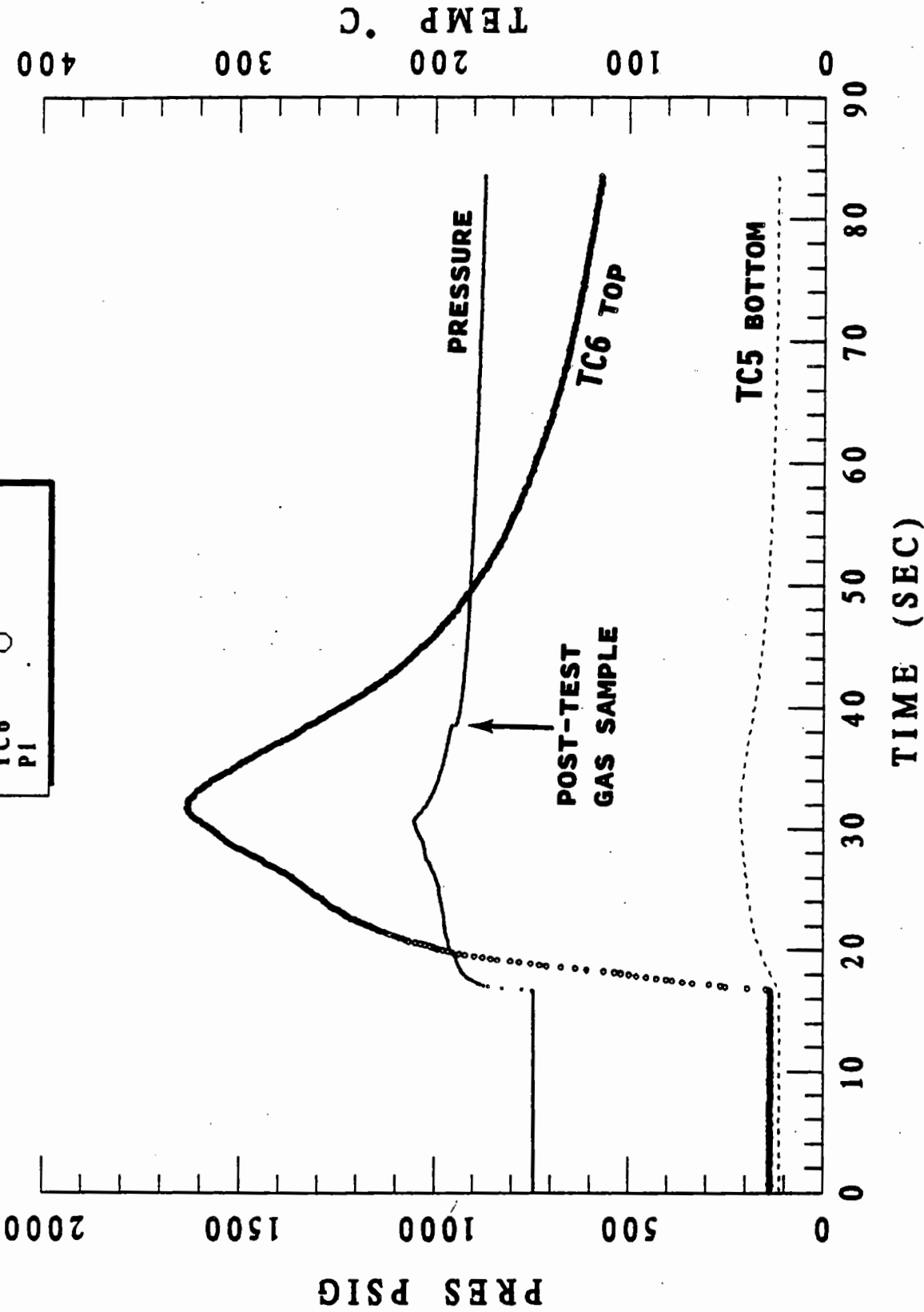

TIME VS. P, TC5, TC6

Fig. 5-2 Containment response to reaction from Test T0128-1.

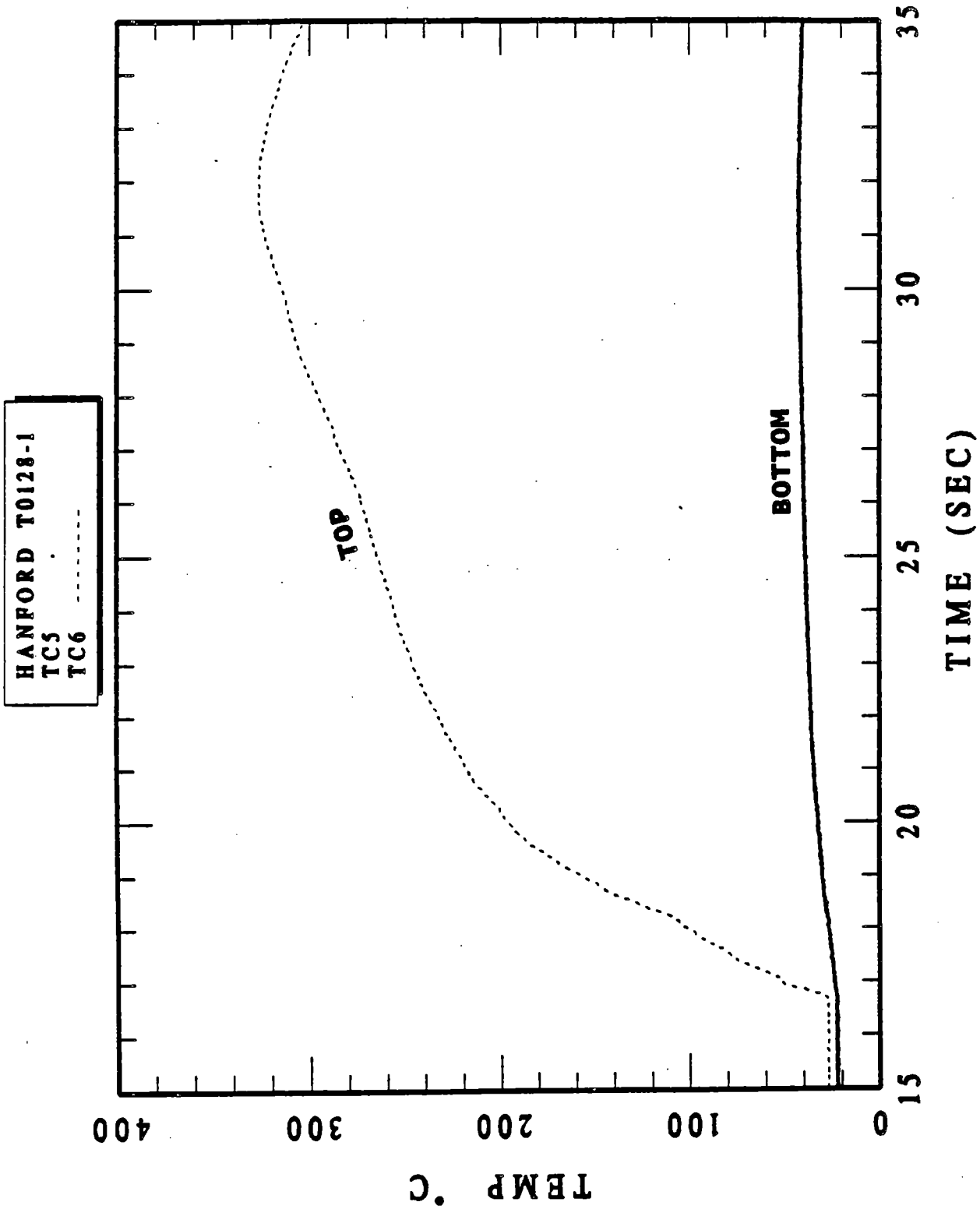

TIME VS TC5, TC6

Fig. 5-3 Expanded scale of containment thermocouple response.

assuming constant temperature where

n is the number of moles of gas

P is the pressure

V is the containment volume

The first term on the right-hand side of Eq. (5-1) is evaluated using test pressure data as

$$\frac{dP}{P} = \frac{34}{(745 + 14.7)} = 0.0448$$

The second term can be estimated from the 4 L containment volume and the .05 L gas sample volume as;

$$\frac{dV}{V} = \frac{.05}{4} = 0.0125$$

Therefore, the net relative change in moles of gas is estimated to be

$$\frac{dn}{n} = .0448 + .0125 = 0.0573$$

The initial reference moles of gas

$$n = \frac{4}{22.4} \times 52 = 9.286 \text{ mole}$$

so that the new gas evolved is

$$\Delta n = 9.286 \times .0573 = 0.532 \text{ mole}$$

One can compare this to the initial inventory of ferrocyanide.

The InFarm-1 bottom sample is 26 wt% ferrocyanide of which ≈ 94 wt% is $\text{Na}_2\text{NiFe}(\text{CN})_6$, (Mw = 316) and ≈ 6 wt% $\text{NaCsNiFe}(\text{CN})_6$, (Mw = 426). The total sample charge for test T0128-1 is 49.8 gm. These considerations lead to a total of 0.0403 mole of ferrocyanide.

The ratio of the estimated moles of new gas (0.532) to moles of ferrocyanide (0.0403) is given below as

$$\frac{\text{moles of gas evolved}}{\text{moles of ferrocyanide}} = \frac{0.532}{.0403} = 13.2$$

This measured ratio compares favorably with theoretical estimates of between 12 and 14 moles of gas for ferrocyanide oxidation reactions.

6.0 COMPARISON WITH OTHER RELATED RESULTS

Table 6-1 shows a comparison of results from the present test T0127-1 with other In-Farm 1 bottom reaction rate results previously reported in Refs. [4] and [5].

Table 6-1
Comparison of Related Propagation Rate Tests

Test	Material	Pressure atm	Initial Temperature °C	Specific Gravity	Reaction Propagation Rate cm/min
T0727-1	IF1B	1	26	1.23	10
*T0127-1	IF1B	10	60	1.26	16
T0819-1	VWW	50	60	1.25	132
**T0128-1	IF1B	53	60	1.33	32

*Ref. [4]

**Subject of this report.

IF1B - In-Farm 1 bottom flow sheet material.

VWW - Vendor supplied material.

7.0 REFERENCES

1. Letter; R. J. Cash to H. K. Fauske, "Subject: Aerosol Propagation Tests and Parametric Pressure Propagation Test", January 12, 1993.
2. FAI/92-66 (Revised), "Test Plans and Procedures for Determination of Reaction Propagation Velocity in Sodium Nickel Ferrocyanide Compounds", July, 1992.
3. FAI/92-81, "Adiabatic Calorimetry and Reaction Propagation Rate Tests with Synthetic Ferrocyanide Materials Including UPlant-1, UPlant-2, In-Farm 1, In-Farm 2, and Vendor-Procured Sodium Nickel Ferrocyanide", July, 1992.
4. FAI/93-12, "Summary Report on Parametric Pressure Propagation Test T0127-1", Jan., 1993.
5. Letter; H. K. Fauske to R. J. Cash, Subject: "Status Report on Reaction Propagation Rate Tests with Synthetic Sodium Nickel Ferrocyanide Material", September 21, 1993.

APPENDIX A

Letter from R. J. Cash to H. K. Fauske (Ref. [1])

H. K. Fauske
Page 2
January 12, 1993

9350199

Photographs are requested of the deposits inside of the chamber after the test. The filter papers and O rings from the aerosol filter should be weighed (to four significant figures) before and after aerosol loading to determine the mass of aerosol collected. (Rental of a balance, as necessary, to make these measurements is approved.) Quartz filter papers will be used and should be handled with tweezers only, since sodium can be picked up from human hands. Filter paper holders have been provided to you for handling and shipping purposes.

It is desirable to make a material balance on the cesium and other metallic elements during this test. The inside of the chamber should be lined with aluminum foil to collect any cesium plate-out on exposed surfaces. The aerosol should be removed from the vent gas by filtering, and all of the remaining solid reaction products should be weighed. The gas samples, loaded filter paper, solid reaction products, and foil liner should be returned to WHC for analysis as soon as possible after completion of each test.

Perform the second aerosol test at an initial temperature of 120 °C but with all other conditions kept the same as the first test; the same data measurements should be made. It is expected that the 1 wt % water added to the test material will be retained within the sample at 120 °C up to the point of ignition of the second test reaction.

Please submit the aerosol propagation test procedure for WHC approval prior to conducting these tests.

It is requested that you perform one additional propagation test at an initial pressure of 10 atmospheres absolute using an argon environment. Use dry (0 wt% water) In-Farm-1 bottom fraction material for this test, the 25 mm diameter test bed, an initial temperature of 60 °C, a specific gravity of about 1.2 (actual density measured), and a particle size as screened through a 140 mesh screen. This test can be conducted in the 49 liter chamber, if you choose. Obtain a gas sample of the containment atmosphere before and after the reaction. Please provide a detailed gas sampling procedure for approval prior to conducting this test. Use of the WHC-provided samplers (NUPRO) with end caps to provide a second seal and to protect threaded connections is requested. Please report the results of these tests, including the temperatures of the chamber gas as a function of time, in a summary report, available for public release.

Please provide measured gas temperatures within the containment atmosphere (and provide the location of the thermocouples) as a function of time for each propagation test conducted to date with the disodium mononickel ferrocyanide mixtures. The gas temperatures and pressure measurements during the reaction time and during cooling time are desired. Temperature and pressure measurements of the containment gas atmosphere are also needed at the time that the gas samples were/are obtained. Your prompt response to this request for tests completed to date would be appreciated.

H. K. Fauske
Page 3
January 12, 1993

9350199

About 1.4 kg of additional In-Farm-1 bottom fraction simulant material was shipped to you on January 5, 1993. The composition of the In-Farm-1 bottom fraction simulant is still being determined by laboratory analysis and will be provided to you in the near future so that the final six screening propagation tests can be conducted. About one Kg of U-Plant-1 sludge will be prepared and shipped to you for the bake out tests discussed at the December 9 and 10, 1992 meeting at Hanford. Additional gas sampler (NUPRO) containers are also being shipped to you.

For your information the gas analysis of the containment atmosphere gases for four propagation tests conducted previously are listed in Table 1. It should be noted that analytical results of two of the pretest samples indicate that there is a concern about the initial condition of the test chamber atmosphere. Either the gas sampling was not conducted properly or the containment atmosphere was not adequately purged. See footnotes of Table 1.

Please address questions to D. W. Jeppson at (509) 376-6058 or to me at (509) 373-3132.

Very truly yours,



R. J. Cash, Manager
Ferrocyanide Safety Technology
Tank Waste Remediation System

fm

TABLE 1
 Gas Analysis of Containment Gases for Propagation Tests

Sample	Mole %											
	CO ₂	Ar	O ₂	N ₂	CO	He	H ₂	CH ₄	H ₂ O	NO	NO ₂	SO ₂
T0820-1-Pre	<0.01	99.99	<0.01	0.003	<0.10	<0.01	<0.01	<0.01	<0.01	<0.01	<0.01	<0.01
T0820-1-After	1.08	95.4	0.26	3.26	<0.10	<0.01	<0.01	<0.01	<0.01	0.02	<0.01	<0.01
T0821-1-Pre	0.02	92.1	1.62	6.27	<0.10	<0.01	<0.01	<0.01	<0.01	<0.01	<0.01	<0.01
T0821-1-After	14.8	24.2	0.04	45.7	<0.10	<0.01	0.03	<0.01	<0.01	15.3	<0.01	<0.01
T0825-1-Pre*	0.10	54.6	9.21	36.1	<0.10	<0.01	<0.01	<0.01	<0.01	<0.01	<0.01	<0.01
T0825-1-After	3.90	84.8	0.09	11.2	<0.10	<0.01	0.01	<0.01	<0.01	0.01	<0.01	<0.01
T0826-1-Pre	<0.01	99.98	<0.01	0.02	<0.02	<0.01	<0.01	<0.01	<0.01	<0.01	<0.01	<0.01
T0826-1-After	0.61	97.5	0.03	1.75	<0.10	<0.01	0.02	<0.01	<0.01	0.01	<0.01	<0.01

* This sample bottle (FAI supplied) was at low pressure and the valve was reported by the analytical laboratory to be leaking.

Note: Sample T0821-1-Pre results may imply that adequate purging of the chamber was not done prior to performance of the test.

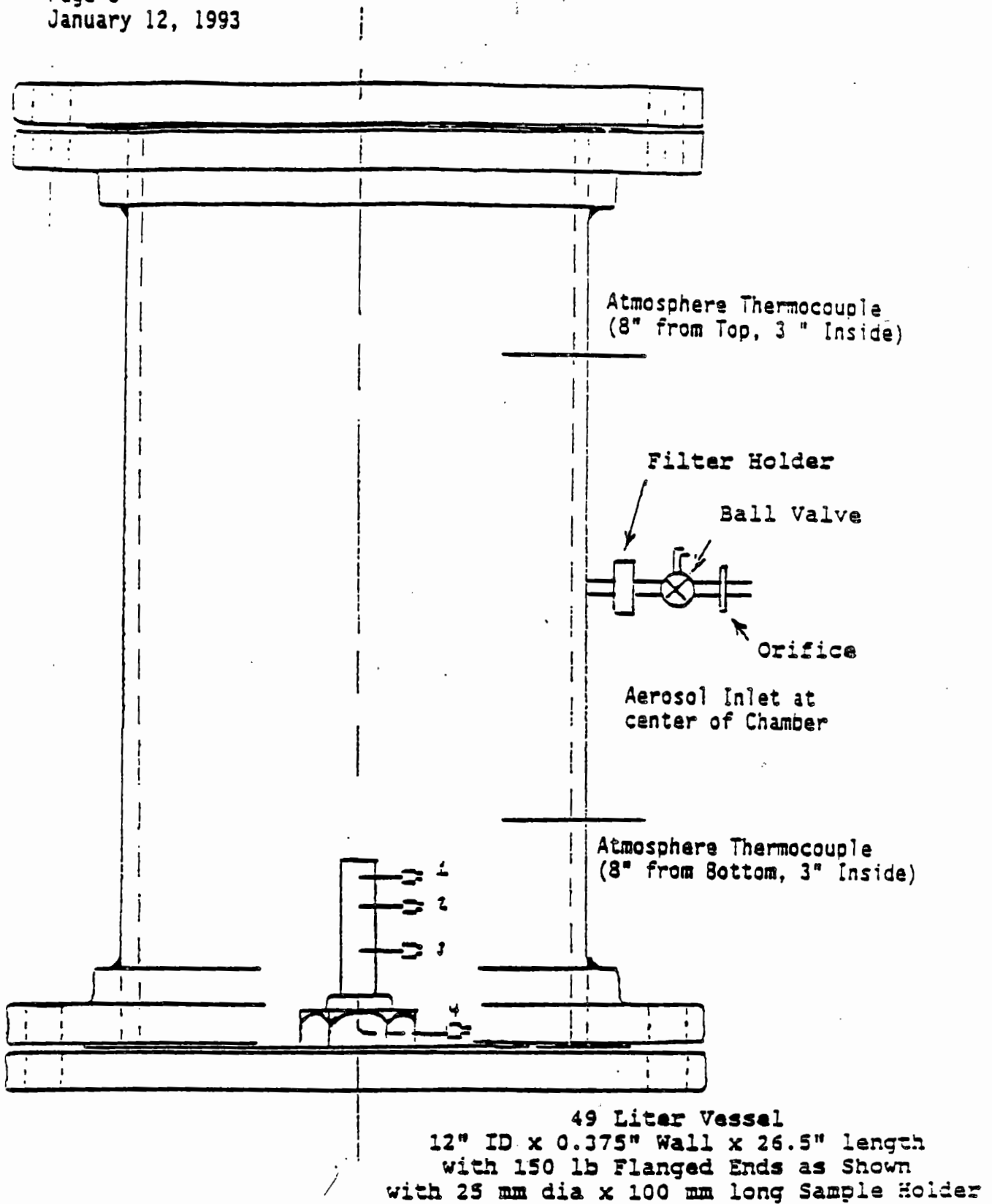

Figure 1
Aerosol Test Containment Vessel

APPENDIX B
Test Procedures

SUPPLEMENTAL PROCEDURE FOR TAKING PRE- AND
POST-TEST TEST CELL CONTAINMENT GAS SAMPLE

(REVISED: 26 Jan 93)

1.0 INTRODUCTION

This operating procedure covers the taking of test cell containment gas samples for ferrocyanide reaction rate propagation tests conducted for Westinghouse Hanford Company and supplements the general test procedures as defined in Ref. [1]*. The procedure is designed to provide consistency and uniformity in the gas sample taking operations and minimize the potential for unwanted leakage or other sources of loss of data.

2.0 PROCEDURE

This procedure is subdivided into four parts. Part 1 defines the pre-test sample cylinder preparations and test cell containment purge. Part 2 define the pre-test gas sample taking activity. Part 3 defines the post-test sample taking activity. Part 4 covers the gas sample identification procedures.

2.1 PRE-TEST PREPARATIONS

Use only gas sample container provided by Westinghouse Hanford Company (NUPRO style with special end caps) for this purpose. The test cell and gas sample installation will be configured as shown in Fig. 2.1-1. However, prior to achieving this configuration both the containment volume and the gas sample cylinder connection lines must be prepared and checked for leak tightness.

*. FAI/92-66 (Revised), "Test Plans and Procedures for Determination of Reaction Propagation Velocity in Sodium Nickel Ferrocyanide Compounds", (July, 1992).

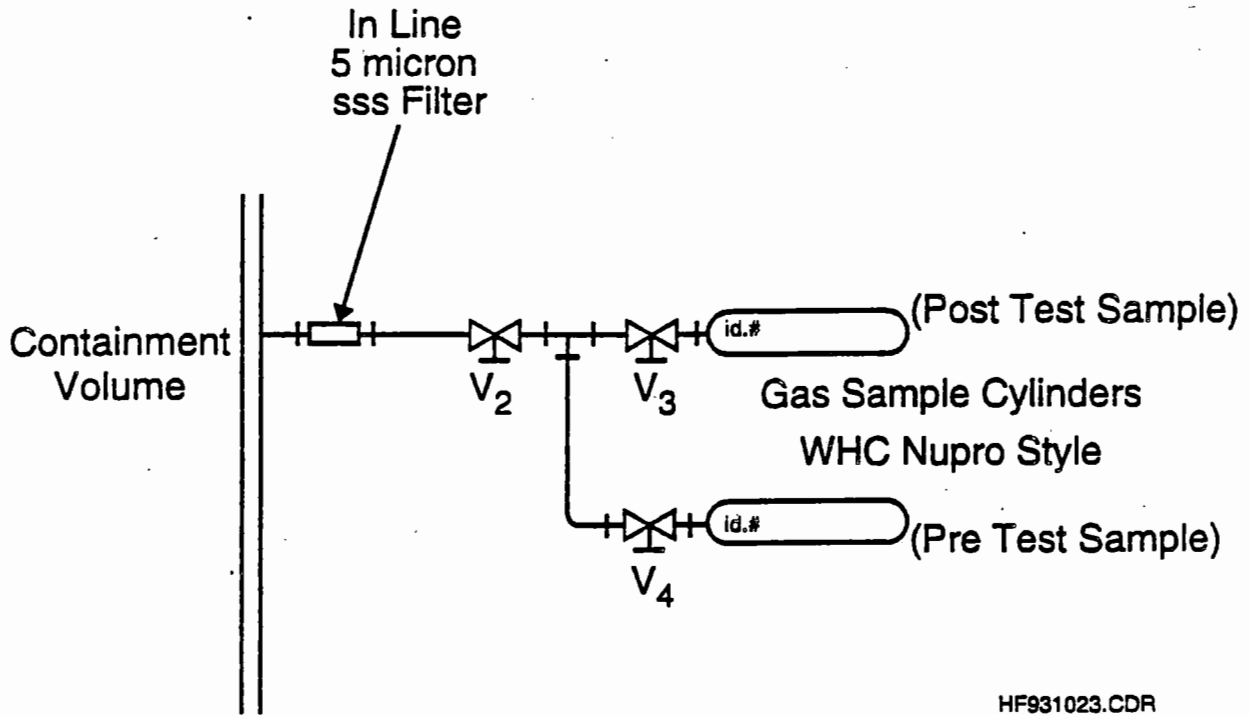

HF931023.CDR

Figure 2.1-1 Installed gas sample cylinders.

2.1.1 GAS SAMPLE CYLINDER

- (1) Label gas sample cylinder and valve.

Label ID Pre Test FAI-3 // Post Test FAI-6

Date of this verification 28 Jan 93



- (2) Prior to test purge two cylinders for each test for five cycles and for each cylinder end the last cycle with a 30 min evacuation:

- (2.1) Label each gas sample cylinder with test ID number and designated pre- and post-test sample.



- (2.2) Purge and evacuate with gas sample cylinder configured according to Fig. 2.1-2.



VACUUM HOLD					
MIN	TIME		CYCLE	VACUUM	FILL
10	<u>06:30</u>	to <u>06:50</u>	1	<u>28"</u>	<u>10 PSI 6</u>
10	<u>06:52</u>	to <u>07:10</u>	2	<u>28"</u>	<u>10 PSI 6</u>
10	<u>07:12</u>	to <u>07:45</u>	3	<u>28"</u>	<u>10 PSI 6</u>
10	<u>07:47</u>	to <u>08:20</u>	4	<u>28"</u>	<u>10 PSI 6</u>
30	<u>08:23</u>	to <u>09:35</u>	5	<u>28"</u>	X

- (2.3) At end of purge, cap gas sample cylinder until ready for use.

2.1.2 CONTAINMENT VOLUME

The containment volume fittings and flanges should be checked for leak tightness at some time prior to testing. This section of the procedure assures a proper argon test atmosphere and verifies the leak tight status.

Prior to the test (propagation reaction rate test) the containment volume should be 99.9% argon or better and be set at the prescribed test pressure. Since on-site analysis of the containment environment is not

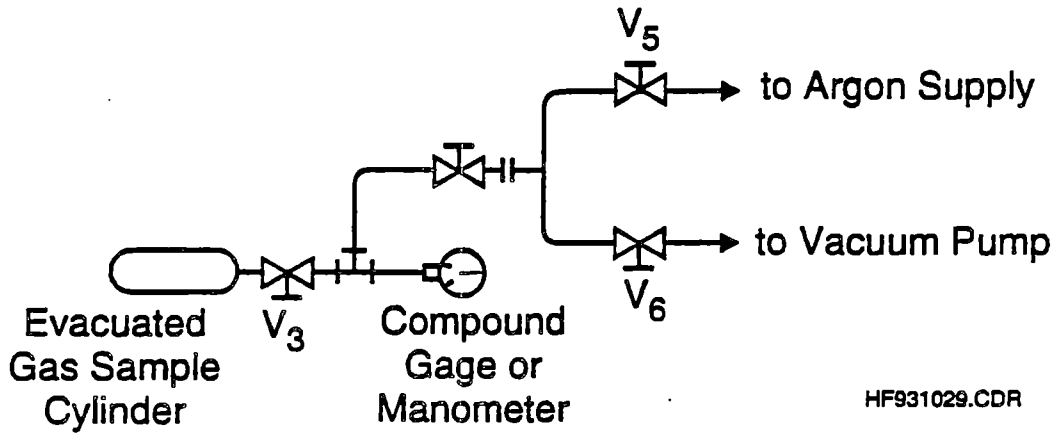

HF931029.CDR

Figure 2.1-2 Configuration of gas sample cylinder for purging and final evacuation.

possible, the desired argon atmosphere will be established by a five cycle evacuation and argon fill procedure.

Purging of the containment volume should be completed just prior to the test activities. The purge configuration is shown in Fig. 2.1-3. The purge procedure is as follows:

(1) Attach prepared gas sample cylinders to valve V2 per Fig. 2.1-3.

(2) Set up for purge per Fig. 2.1-3.

Valve Configuration -

V1	Open
V2	Open
V3 & V4	Closed
V5 & V6	Used for purge cycles
V7 & V8	Open



(3) Purge cycle - record pressure readings.



<u>CYCLE</u>	<u>VACUUM</u>	<u>FILL</u>
1	<u>28"</u>	<u>10 PSIG</u>
2	<u>28"</u>	<u>10 PSIG</u>
3	<u>28"</u>	<u>10 PSIG</u>
4	<u>28"</u>	<u>10 PSIG</u>
5	<u>28"</u>	— ← 750 PSIG

(4) At end of purge cycle: Close V2 and V7 remove manometer or low range pressure transducer and cap valve, V7.



(5) Pressure containment to test pressure and check for leaks - must hold pressure within 2% for 1 hr (Note: if leaks are discovered and cannot be fixed at pressure, reduce pressure, fix leak and repeat purge procedure).

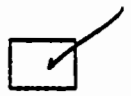

hold

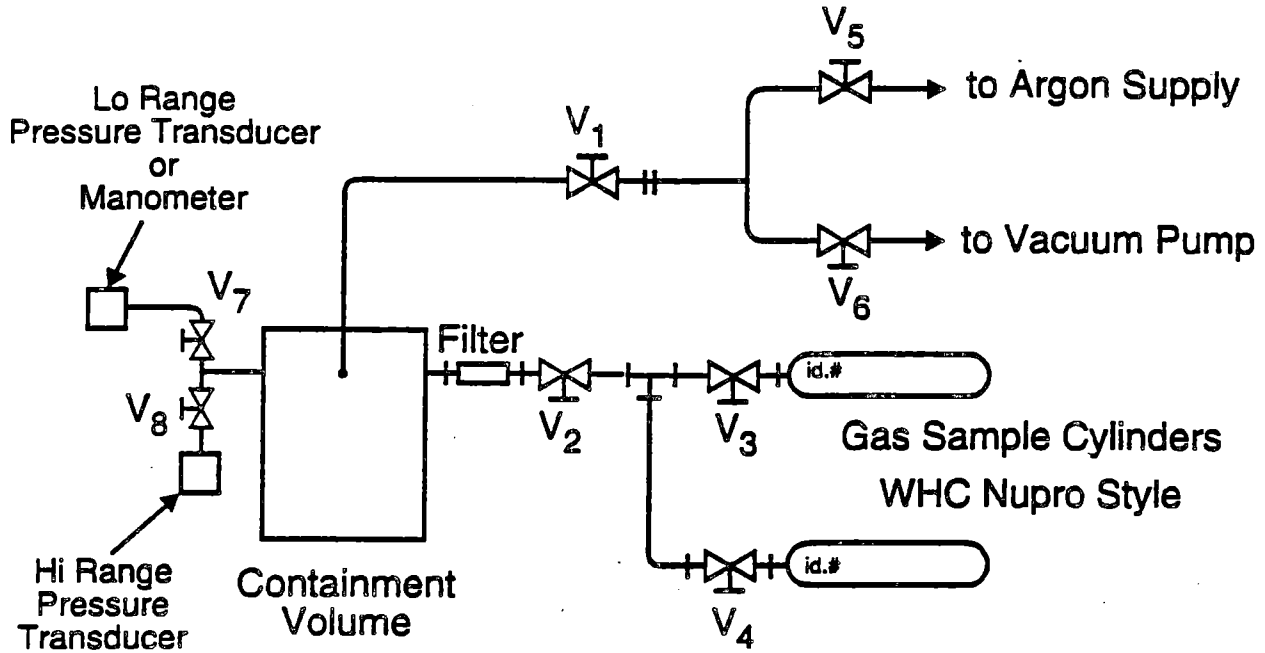

HF931021.CDR

Figure 2.1-3 Configuration of test apparatus for purging.

2.2 PRE-TEST GAS SAMPLE TAKING ACTIVITY

*772 dvm
768 PSIG computer*

(1) Containment vessel is leak tight and at pressure.

Record: Pressure 770 ± 2 PSIG
Temperature T05 20°C T06 20°C

(2) Open V2 and V3 - hold open for 30 sec.

*756 PSIG computer
760 dvm*

(3) Record containment vessel.

Record: Pressure 758 ± 2 PSIG
Temperature T05 19°C T06 19°C

(4) Close V2 and V3. Adjust containment vessel pressure if required.

[Signature]
(5) Remove and cap gas sample cylinder.

(6) Attach properly labeled post-test gas sample cylinder to test apparatus per Fig. 2.1-1.

(7) Run test per established test plan.

2.3 POST-TEST GAS SAMPLE ACTIVITY

(1) After test burn is verified as soon as practical -

Record: Time After Start of Test _____

Pressure _____

recheck

Temperature _____

(2) Open V2 and V3 - hold open for 30 sec.

(3) Record containment vessel -

Pressure _____

Temperature _____

(4) Close V2 and V3.

(5) Remove and cap gas sample cylinder.

2.4 IDENTIFICATION VERIFICATION

Verify pre- and post-test gas sample identification and transfer data to following summary table.

GAS SAMPLE SUMMARY DATA SHEETTEST ID T0128-1DATE 28 Jan 93PRE-TEST GAS SAMPLE:

- (a) Gas Sample Cylinder Identification: FBI 3
- (b) Cylinder Volume: 50 cc
- (c) Test Label as Shipped: T0128-1 PRETEST GAS SAMPLE
Container Pressure \approx 750 psig
FBI 74213
- (d) Pre-Sample Pressure: Vac 1" Hg also \pm 1/2 inch
- (e) Containment Volume: Pressure Temperature
 Before Sample: 770 psig 20°C
 After Sample: 758 psig 19°C

POST-TEST GAS SAMPLE:

- (a) Gas Sample Cylinder Identification: FBI 6
- (b) Cylinder Volume: 50 cc
- (c) Test Label as Shipped: T0128-1 POST TEST GAS SAMPLE
Container Pressure \approx 770 psig
FBI 29316
- (d) Pre-Sample Pressure: Vac 1" Hg also \pm 1/2 inch
- (e) Containment Volume: Pressure Temperature
 Before Sample: 796 psig TC 6 250°C TL 40°C
 After Sample: 937 psig " "

APPENDIX C

Miscellaneous Test Data Records

**Data Sheet Form L-001
Reaction Propagation Test**

Date 28 Jan 93
 Test ID T O 128-1
 Material In Form L Bottom
 Fill Height See data sheet
 Mass 49.8 g
 Initial Pressure 745 psig
 Initial Temperature 60°C nominal
 Final Pressure 779 psig
 Final Gas Temperature/Time 25°C 1
 Test Configuration next pg

Time, if yes

Gas Sample Yes No
 Residue Sample Yes No

Test Notes Test conducted in 4 h
containment vessel, operation
satisfactory

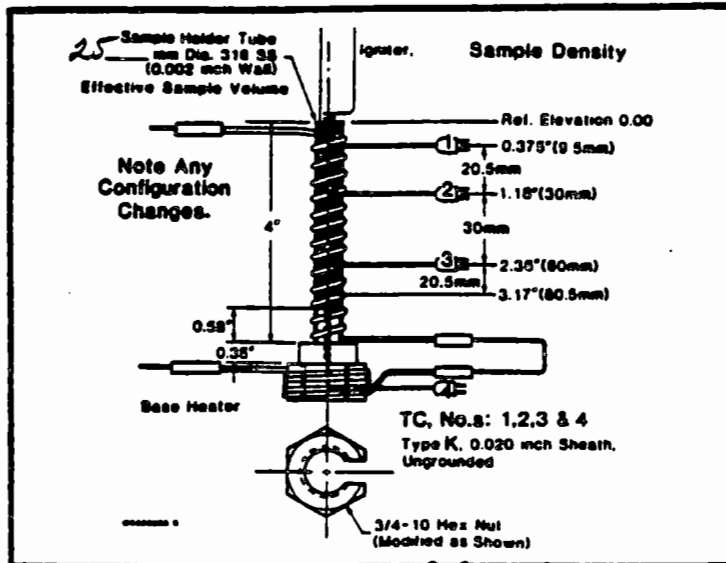

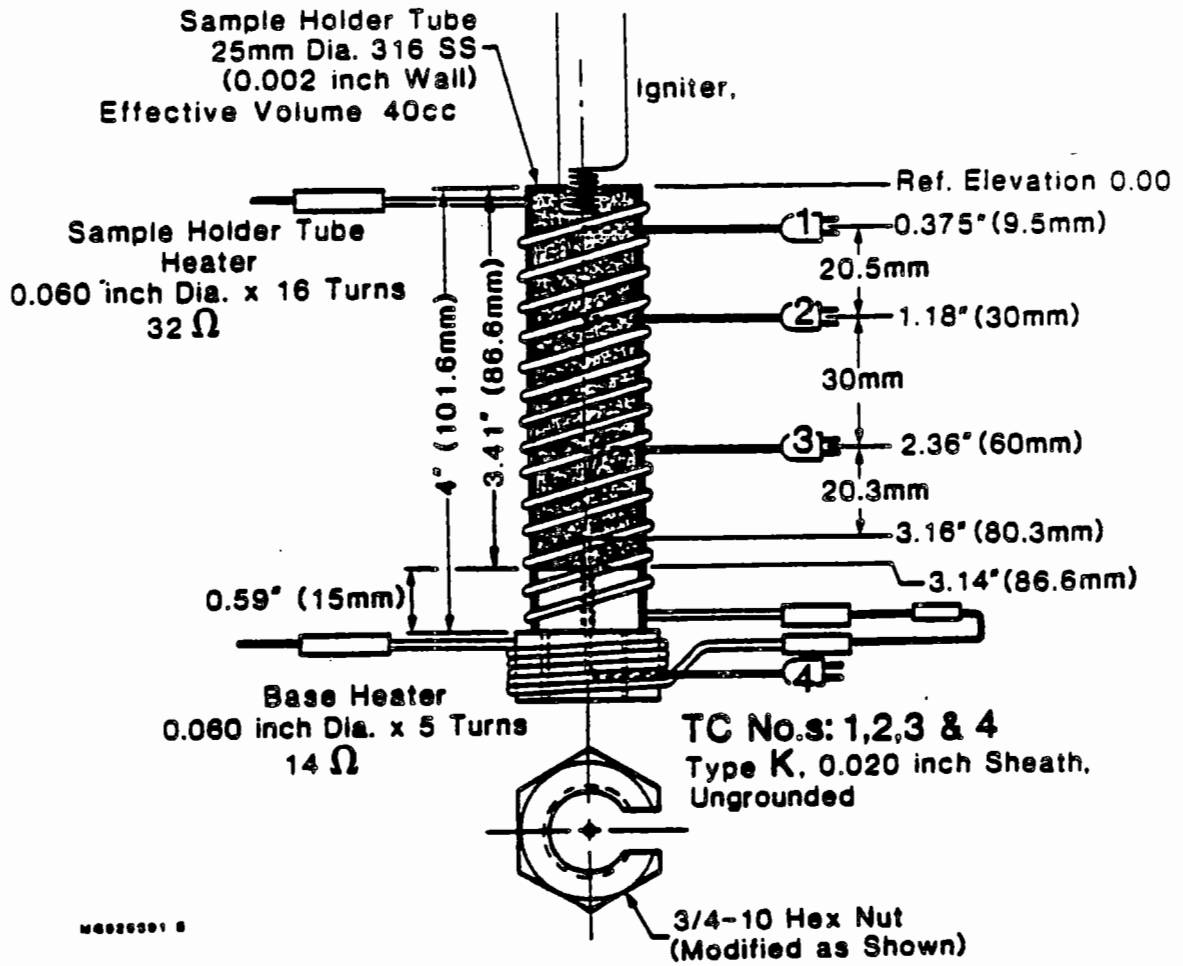

Fig. 2-3 25 mm diameter sample holder used in burn velocity tests.

28 Jan 1993

WHC PROPAGATION TEST 13 TO12F-1

TEST PRESSURE ----- 750 psig

SAMPLE TEMPERATURE ----- 60°C

Sample Holder 25 mm dia x 101 mm lg

Verify dimensions:

Overall height _____

TC1	<u>3/8" FROM TOP</u>	No.	<u>38</u>
TC2	<u>7/16" FROM TOP</u>	No.	<u>39</u>
TC3	<u>2 1/32" FROM TOP</u>	No.	<u>10</u>
TC4	<u>3/16" FROM BOTTOM</u> BASE	No.	<u>50</u>

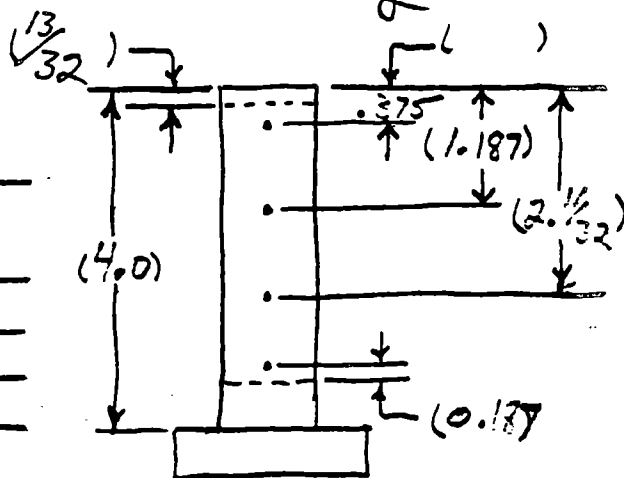

Containment: 4L.

TC5	<u>1/2" FROM BOTTOM</u> <u>1" IN FROM WALL</u>	No.	<u>104</u>	bottom
TC6	<u>1" FROM TOP AND WALL</u>	No.	<u>105</u>	top

Pressure Transducers

High Range 1250.0 psi fs Cal Fac 250.0 psi/volt

Sample: INFARM-1 Bottom 0% water
Source Ref: INFARM-13-REV-6A BOTTOM 60% 12-21-92

Sample Wgt 49.8 gm SG. 1.33
Sample height 13/32 from top

Igniter wgt 4.4 gm

Date 28 Jan 93

Test T0128-1

Calculation of Sample Packed Density

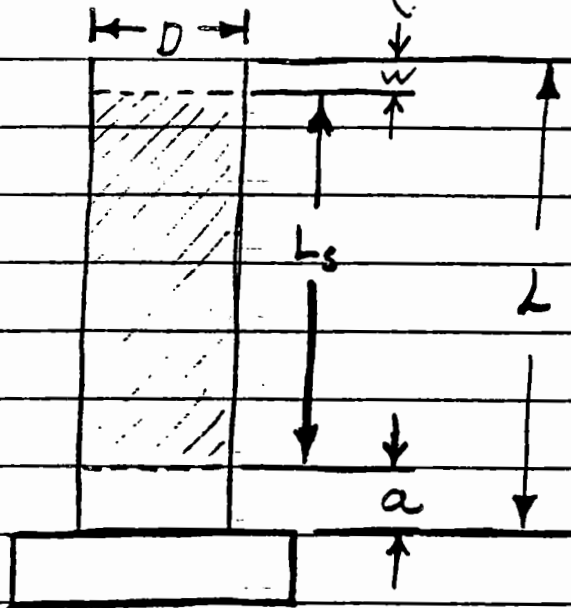

Sample wgt.

 M_s 49.8 gm

D 25 mm

L 4.0 inch 101.6 mm

a 0.59 inch 15.0 mm

W $1\frac{3}{32}$ inch 10.3 mm

$$L_s = L - (a + w) = 76.3 \text{ mm}$$

use dimensions in (mm)

$$V_s = \frac{\pi D^2 L_s}{4} \times 10^{-3} = 37.45 \text{ cm}^3$$

$$\text{Packing Density} = \frac{M_s}{V_s} = \frac{49.8}{37.45} = 1.33$$

DISTRIBUTION

Number of copies

OFFSITE

12	<u>U.S. Department of Energy</u> EM-35, Trevion II Washington, D.C. 20585 John C. Tseng
1	<u>U.S. Department of Energy</u> Savannah River Operations Office P.O. Box A Aiken, South Carolina 29808 Thomas C. Temple
1	Charles S. Abrams 1987 Virginia Idaho Falls, ID 83404
1	David O. Campbell 102 Windham Road Oak Ridge, TN 37830
1	Fred N. Carlson 6965 North 5th West Idaho Falls, ID 83401
1	Donald T. Oakley 409 12th Street SW, Suite 310 Washington, DC 20024-2188
1	Arlin K. Postma 3640 Ballard Road Dallis, Oregon 97338
1	William R. Prindle 1556 Crestline Drive Santa Barbara, CA 93105
1	Alfred Schneider 5005 Hidden Branches Drive Dunwoody, GA 30338
1	<u>Air Products & Chemicals, Inc.</u> 7201 Hamilton Blvd Allentown, PA 18195-1501 George E. Schmauch

DISTRIBUTION (cont)

Number of copies

OFFSITE

- 1 Battelle Columbus Laboratories
505 King Avenue
Columbus, OH 43201-2693

James A. Gieseke
- 2 Brookhaven National Laboratory
Upton, NY 11973

Kamal K. Bandyopadhyay
Morris Reich
- 1 Design Science, Inc.
163 Witherow Road
Sewickley, PA 15143

Gary Powers
- 1 Fauske and Associates, Inc.
16W070 W. 83rd St.
Burr Ridge, IL 60521

Hans K. Fauske
- 1 Florida State University
Department of Chemistry B-164
Tallahassee, FL 32306

Greg R. Choppin
- 1 Harvard University
295 Upland Avenue
Newton Highlands, MA 02161

Melvin W. First
- 1 Hazards Research Corporation
200 Valley Road, Suite 301
Mt. Arlington, NJ 07856

Chester Grelecki
- 1 Lawrence Livermore National Laboratory
P.O. Box 808, L-221
Livermore, CA 94550

Billy C. Hudson

DISTRIBUTION (cont)

Number of copies

OFFSITE

4	<u>Los Alamos National Laboratory</u> P.O. Box 1663 Los Alamos, NM 87545 Steve F. Agnew Steve W. Eisenhower Thomas E. Larson L. Harold Sullivan
1	<u>MIT/Department of Nuclear Engineering</u> 77 Massachusetts Ave. Room 24-102 Cambridge, MA 02139 Mujid S. Kazimi
1	<u>Nuclear Consulting Services, Inc.</u> P.O. Box 29151 Columbus, OH 43229 J. Louis Kovach <u>Oak Ridge National Laboratory</u>
1	Emory D. Collins P.O. Box 2008 7930, MS-6385 Oak Ridge, TN 37831-6385
1	Charles W. Forsberg P.O. Box 2008 MS-6495 Oak Ridge, TN 37831-6495
1	Thomas S. Kress P.O. Box 2009 9108, MS-8088 Oak Ridge, TN 37831-8088
1	<u>Rice University</u> 5211 Paisley Houston, TX 77096 Andrew S. Veletsos

DISTRIBUTION (cont)

Number of copies

OFFSITE

- 1 Sandia National Laboratory
P.O. Box 5800
Albuquerque, NM 87185

Scott E. Slezak
- 4 Science Applications International Corporation
12850 Middlebrook Road
Trevion I, Suite 300
Germantown, MD 20874

Ray S. Daniels (3)
John M. Saveland
- 1 University of South Carolina
Department of Electrical and Computer Engineering
Swearingen Engineering Center
Columbia, SC 29208

Joseph S. Byrd
- 1 University of Washington
Center for Process Analytical Chemistry
Chemistry Department BG-10
Seattle, WA 98195

Bruce R. Kowalski
- 1 Vanderbilt University
P.O. Box 1596, Station B
Nashville, TN 37235

Frank L. Parker

ONSITE

- 11 U.S. Department of Energy,
Richland Field Office

R. F. Christensen (6) A4-02
R. E. Gerton A4-02
A. G. Krasopoulos A5-55
Public Reading Room A1-65
RL Docket File (2) A3-11

DISTRIBUTION (cont)

Number of copiesONSITE

9	<u>Pacific Northwest Laboratory</u>	
	R. T. Allemann	K7-15
	S. A. Bryan	P7-25
	B. M. Johnson	K1-78
	M. A. Lilga	P8-38
	R. D. Scheele	P7-25
	G. F. Schiefelbein	P8-38
	D. M. Strachan	K2-38
	PNL Technical Files	K1-11
	Hanford Technical Library	P8-55
63	<u>Westinghouse Hanford Company</u>	
	H. Babad	R2-08
	D. B. Bechtold	T6-50
	J. R. Bell	R3-09
	D. C. Board	S1-57
	G. L. Borsheim	R2-11
	V. C. Boyles	R1-49
	S. L. Bradley	B3-06
	R. J. Cash (5)	R2-32
	M. D. Crippen	L5-31
	G. M. Christensen	H4-21
	R. D. Crowe	H4-62
	S. J. Dechter	R2-50
	C. DeFigh-Price	R2-31
	J. L. Deichman	B1-59
	D. R. Dickinson	L5-31
	G. T. Dukelow (2)	R2-32
	G. L. Fox	L5-01
	G. T. Frater	R1-51
	J. C. Fulton	R2-31
	K. A. Gasper	R2-08
	J. M. Grigsby	H4-62
	H. D. Harmon	R2-52
	J. M. Held	R3-12
	M. N. Islam	R3-08
	J. R. Jewett	T6-50
	N. W. Kirch	R2-11
	C. A. Kuhlman	B3-30
	M. Kummerer	H4-62
	J. D. McCormack	L5-31
	J. M. McLaren	H0-34
	J. E. Meacham	R2-32
	N. J. Milliken	H4-62
	A. F. Noonan	R2-12
	J. W. Niskas	R2-11
	P. C. Ohl	H5-09

DISTRIBUTION (cont)

Number of copies

ONSITE

Westinghouse Hanford Company (cont)

P. M. Phelps	B3-30
D. N. Price	R2-14
J. G. Propson	R2-18
R. E. Raymond	R1-80
F. R. Reich	L5-63
D. A. Reynolds	R2-11
B. C. Simpson	R2-12
S. R. Tifft	H6-16
H. Toffer	H0-38
R. K. Welty	R1-80
W. P. Whiting	B3-25
J. C. Wiborg	H4-60
W. D. Winkelman	L5-55
D. D. Wodrich	B1-59
W. F. Zuroff	R2-14
Central Files	L8-04
Document Processing and Distribution (2)	L8-15
EDMC	H6-08
Information Release Administration (3)	R1-08
TFIC	R1-20